

Brooks® Expert Support Tool (BEST)

Version 5.14.0.0

Software for Brooks Devices

(SLA Rev B, PC1xx, VDM300, GF40, GF80,
GF1xx, GF095, GP200, Quantim C)

All pressure equipment with an internal pressure greater than 0.5 bar (g) and a size larger than 25 mm or 1" (inch) falls under the Pressure Equipment Directive (PED).

- The Specifications Section of this manual contains instructions related to the PED directive.
- Products described in this manual are in compliance with EN directive 2014/34/EU.
- All Brooks Instrument Flowmeters fall under fluid group 1.
- Products larger than 25 mm or 1" (inch) are in compliance with PED category I, II or III.
- Products of 25 mm or 1" (inch) or smaller are Sound Engineering Practice (SEP).

The Brooks Instrument (electric/electronic) equipment bearing the CE mark has been successfully tested to the regulations of the Electro Magnetic Compatibility (EMC directive 2014/30/EU).

Special attention however is required when selecting the signal cable to be used with CE marked equipment.

Quality of the signal cable, cable glands and connectors:

Brooks Instrument supplies high quality cable(s) which meets the specifications for CE certification.

If you provide your own signal cable you should use a cable which is overall completely screened with a 100% shield.

"D" or "Circular" type connectors used should be shielded with a metal shield. If applicable, metal cable glands must be used providing cable screen clamping.

The cable screen should be connected to the metal shell or gland and shielded at both ends over 360 Degrees.

The shield should be terminated to an earth ground.

Card Edge Connectors are standard non-metallic. The cables used must be screened with 100% shield to comply with CE certification.

The shield should be terminated to an earth ground.

For pin configuration : Please refer to the enclosed Instruction Manual.

European Pressure Equipment Directive (PED)

European Electromagnet Compatibility (EMC)

Dear Customer,

We recommend that you read this manual in its entirety as there have been some changes since previous versions. This will enable efficient and proper use of the Brooks Expert Support Tool software. Should you require any additional information concerning Brooks Expert Support Tool, please feel free to contact your local Brooks Sales and Service Office; see back cover for contact information, or visit us on the web at www.BrooksInstrument.com. We appreciate this opportunity to service your fluid measurement and control requirements, and trust that we will be able to provide you with further assistance in future.

Yours sincerely, Brooks Instrument

Contents

Chapter 1	Introduction	1-1
1.1	Description	1-1
1.2	How to Use This Manual	1-2
1.3	Integrated Help	1-2
Chapter 2	Installation	2-1
2.1	Hardware Requirements	2-1
2.2	System Requirements	2-3
2.3	Installing the Brooks Expert Support Tool Application	2-11
2.4	License Installation	2-14
2.5	Uninstalling the Brooks Expert Support Tool Application	2-15
2.6	Connection Procedure	2-15
2.7	Disconnecting the PC from the Device	2-17
Chapter 3	Basic Operations	3-1
3.1	Main Screen	3-1
3.2	Attaching to a Device	3-2
3.3	Main Graph	3-3
3.4	Closing the Session with the Device and Exiting BEST	3-4
3.5	Brooks Expert Support Tool Conventions	3-4
3.6	Menu Bar	3-6
Chapter 4	File Menu	4-1
Chapter 5	Help Menu Item	5-1
5.1	About Window	5-1
5.1.1	License Info Window	5-2
5.1.2	Install License Window	5-2
5.1.3	EULA Window	5-3
5.2	User Manual Menu	5-3
5.3	ReadMe Menu	5-3
Chapter 6	Window Menu	6-1
Chapter 7	Settings	7-1
7.1	Graph Options	7-1
7.2	Reset All User Options	7-2
7.3	Data Logging Options	7-2
7.4	User Totalizer Options	7-3
7.4.1	User Totalizer Options	7-4
Chapter 8	Monitoring Menu	8-1
8.1	Warning Status	8-1
8.2	Alarm Status	8-3
8.3	User Totalizer Window	8-11
8.4	Graph Window	8-12
8.5	VDM Status Window	8-15
8.6	VDM Heater Diagnostics	8-16

8.7	Data Streaming	8-16
8.8	VDM300 Dry-Down	8-17
8.9	VDM300 Dry-Down Reports	8-19
Chapter 9 Tools Menu		9-1
9.1	Pressure Units Calculator	9-1
9.2	Flow Units Calculator	9-1
9.3	Temperature Units Calculator	9-2
9.4	Density Units Calculator	9-3
Chapter 10 Device Comm Menu		10-1
10.1	Device Connection Window	10-1
10.1.1	Connecting to an Unconfigured Device	10-5
10.2	Terminal Window	10-6
10.3	Script File Window	10-7
Chapter 11 Device Config Menu		11-1
11.1	Firmware	11-2
11.1.1	Update Firmware	11-2
11.1.2	Update Gas Database	11-3
11.2	Dump Files	11-4
11.3	Device Info	11-5
11.4	Gas Page Configuration	11-5
11.5	Model Code Window	11-5
11.6	Customer Part Number Window	11-7
11.7	Wake Up State	11-7
11.8	RT Pressure Controller Direction	11-8
11.9	RT Control Mode	11-8
11.10	Meter Simulate MFC (Meter Calibration)	11-9
11.11	Protocol Settings Window	11-11
11.12	Warnings and Alarms	11-16
11.13	Warning Settings	11-18
11.14	Alarm Settings	11-19
11.15	Restrictor Selection	11-25
11.16	Orifice Selection	11-26
Chapter 12 Device Control Menu		12-1
12.1	Reboot Device	12-1
12.2	Valve Control	12-1
12.3	Executing Mode	12-3
Chapter 13 Calibration Menu		13-1
13.1	Pressure Controller Setup Diagram	13-2
13.2	Sensor Zero	13-2
13.3	Flow Sensor Zero	13-2
13.4	Pressure Sensor Zero	13-4
13.5	Analog Output Calibration	13-6
13.6	Analog Input Calibration	13-9
13.7	RT/Aux Input Calibration	13-13
13.8	Cal Pages	13-15
13.9	Flow Cal Pages	13-16
13.10	Pressure Cal Pages	13-17
13.11	Calibration	13-18

Installation and Operation Manual

X-SW-BEST-RevB

Part Number: 541B197AAG

January, 2024

Brooks® Expert Support Tool

13.12	Flow Calibration	13-19
13.13	GF40 Device Flow Calibration	13-34
13.14	Warp	13-38
13.15	Bin Select (GF)	13-40
13.16	Pressure Controller Calibration	13-41
13.17	RT Device Calibration	13-52
13.18	Response Tuning (Flow)	13-53
13.19	Response Tuning (Pressure)	13-58
13.20	Print Top Label	13-63

Figures

Figure 1-1 BEST Main Screen	1-1
Figure 2-1 RS232 to RS485 Converter, cable	2-2
Figure 2-2 USB to RS485 Converter	2-2
Figure 2-3 Standard USB to Micro USB cable	2-3
Figure 2-4 Running Setup.exe as an Admin	2-12
Figure 2-5 Installer Software Component Menu	2-13
Figure 2-6 License Installation Window	2-14
Figure 2-7 License Information Window	2-15
Figure 2-8 RS232 to RS485 Connection	2-16
Figure 2-9 Typical Diagnostics Port Connection (SLA Rev B Model shown)	2-16
Figure 2-10 Typical Diagnostics Port Connection (Pc1xx Model shown)	2-17
Figure 2-11 Micro USB Diagnostic Port (VDM300 model shown)	2-17
Figure 3-1 Main Screen with Device Connection Window	3-1
Figure 3-2 Device Connection Window, Device Attached	3-2
Figure 3-3 Executing Mode Window	3-3
Figure 3-4 Idle Mode Window	3-3
Figure 3-5 Graph Window	3-4
Figure 3-6 Example Numeric Up/Down Control	3-5
Figure 4-1 File->Exit Menu	4-1
Figure 5-1 Help Menu	5-1
Figure 5-2 About Window	5-1
Figure 5-3 License Information Window	5-2
Figure 5-4 License Install Window	5-3
Figure 6-1 Window Menu	6-1
Figure 6-2 Cascaded Window Layout	6-2
Figure 6-3 Tiled Window Layout	6-2
Figure 6-4 Minimized Windows	6-3
Figure 7-1 Settings Menu	7-1
Figure 7-2 Graph Options Window	7-1
Figure 7-3 Data Logging Options	7-3
Figure 7-4 User Totalizer Options	7-3
Figure 7-5 EthernetIP Totalizer	7-4
Figure 8-1 Monitoring Menu	8-1
Figure 8-2 Warning Status Window	8-2
Figure 8-3 VDM Warning Status Window	8-2
Figure 8-4 Alarm Status Window (RS485)	8-3
Figure 8-5 Alarm Status Window (FieldBus)	8-4
Figure 8-6 VDM Alarm Status Window	8-5
Figure 8-7 VDM Ethercat Alarm Status Window	8-5
Figure 8-8 GF40 Alarm Status	8-6
Figure 8-9 EthernetIP Alarm Status Window, Status Tab	8-7
Figure 8-10 EthernetIP Alarm Status Window, Errors Tab	8-8
Figure 8-11 EthernetIP Alarm Status Window, Alarms Tab	8-9
Figure 8-12 EthernetIP Alarm Status Window, Warnings Tab	8-10
Figure 8-13 GP200 Alarm Status Window	8-11
Figure 8-14 User Totalizer Window	8-12
Figure 8-15 Main Graph Window	8-12
Figure 8-16 Main Graph Window with Cursor	8-14

Figure 8-17 Main Graph Window with Context Menu	8-14
Figure 8-18 Graph Window Zoomed	8-15
Figure 8-19 VDM Status Window	8-15
Figure 8-20 VDM Heater Window	8-16
Figure 8-21 Streaming Window	8-17
Figure 8-22 VDM300 Dry-Down Window	8-18
Figure 8-23 VDM300 Dry-Down Settings Window	8-18
Figure 8-24 VDM300 Dry-Down Report Window	8-19
Figure 9-1 Tools Menu	9-1
Figure 9-2 Pressure Units Calculator	9-1
Figure 9-3 : Flow Units Calculator	9-2
Figure 9-4 Temperature Units Calculator	9-2
Figure 9-5 Density Units Calculator	9-3
Figure 10-1 Device Comm Menu	10-1
Figure 10-2 Device Connection Window, with no devices attached	10-1
Figure 10-3 No Device Connected	10-2
Figure 10-4 Connection Window, Single Device Attached	10-3
Figure 10-5 Device Connection Window, Multiple Devices Connected	10-4
Figure 10-6 Fix Model Code Window	10-5
Figure 10-7 Terminal Window	10-7
Figure 10-8 Script File Window	10-7
Figure 10-9 Sample Script File	10-8
Figure 11-1 Device Config Menu	11-1
Figure 11-2 BEST Control Message	11-2
Figure 11-3 Firmware Menu	11-2
Figure 11-4 Firmware Update Window	11-3
Figure 11-5 Gas Database Window	11-3
Figure 11-6 Dump File Window	11-4
Figure 11-7 Device Info Window	11-5
Figure 11-8 Model Code Window	11-6
Figure 11-9 Customer Part Number Window	11-7
Figure 11-10 Wake Up State Window	11-8
Figure 11-11 Pressure Controller Direction Window	11-8
Figure 11-12 RT Control Mode Window	11-9
Figure 11-13 Meter Simulate MFC Window	11-10
Figure 11-14 Protocol Setting (S-Protocol) Window	11-11
Figure 11-15 Protocol Settings (DeviceNet) Window	11-13
Figure 11-16 Protocol Settings (EtherCAT) Window	11-14
Figure 11-17 Protocol Settings (FieldBus) Window	11-14
Figure 11-18 Protocol Settings (EthernetIP) Window, General Tab	11-15
Figure 11-19 Protocol Settings (EthernetIP) Window, Network Tab	11-16
Figure 11-20 Warning Settings Window, Ethercat	11-18
Figure 11-21 Warning Settings Window, VDM	11-18
Figure 11-22 Alarm Settings RS485 Window, Alarms Tab	11-20
Figure 11-23 Alarm Settings RS485 Window, Contact/Latch Tab	11-20
Figure 11-24 Alarm Settings Profibus Window	11-21
Figure 11-25 Alarm Settings DeviceNet/EtherCAT Window	11-21
Figure 11-26 Alarm Settings (Field Bus), Alarms Tab	11-22
Figure 11-27 Alarm Settings (Field Bus), Totalizers Tab	11-22
Figure 11-28 GF40 Alarm Settings, Alarms Tab	11-23
Figure 11-29 GF40 Alarm Settings Window, Contacts/Latch tab	11-24
Figure 11-30 GP200 Alarm Settings Window	11-25

Figure 11-31 Restrictor Selection Window	11-26
Figure 11-32 Orifice Selection Window	11-27
Figure 12-1 DeviceControl Menu	12-1
Figure 12-2 Reboot Device Window	12-1
Figure 12-3 Valve Control Window	12-2
Figure 13-1 Calibration Menu	13-1
Figure 13-2 Pressure Controller Setup Diagram	13-2
Figure 13-3 Flow Sensor Zero Window	13-3
Figure 13-4 Zero Drift History Window	13-4
Figure 13-5 Sensor Zero Window for psia Pressure Device, PSIA Warning	13-5
Figure 13-6 Pressure Sensor Calibration (Straight Offset Method)	13-5
Figure 13-7 Typical Setup for Calibrating an Output Voltage	13-6
Figure 13-8 Typical Setup for Calibrating an Output Current	13-6
Figure 13-9 Analog Output Calibration Window	13-7
Figure 13-10 Analog Output Check Window	13-8
Figure 13-11 Analog Output Cal, Low Point	13-8
Figure 13-12 Analog Output Cal, High Point	13-9
Figure 13-13 Typical Setup for Calibrating an Analog Input for Voltage	13-10
Figure 13-14 Typical Setup for Calibrating an Analog Input for Current	13-11
Figure 13-15 Analog Input Calibration Window	13-12
Figure 13-16 Analog Input, Low	13-12
Figure 13-17 Analog Input, High	13-13
Figure 13-18 Typical Setup for Calibrating the RT Input	13-14
Figure 13-19 RT/Aux Analog Input	13-14
Figure 13-20 RT/Aux Analog Input Cal, Low	13-15
Figure 13-21 RT/Aux Analog Input Cal, High	13-15
Figure 13-22 Cal Pages Window, for Flow Devices	13-16
Figure 13-23 Cal Pages Window, for Pressure Devices	13-17
Figure 13-24 Create Default Page Window, for Pressure Devices	13-18
Figure 13-25 Flow Calibration Window	13-20
Figure 13-26 Flow Calibration, Calibration Tab	13-21
Figure 13-27 Edit Setpoints Window	13-22
Figure 13-28 Calibration Tab, Filled Out	13-23
Figure 13-29 Flow Cal, Meter Setpoint Prompt	13-24
Figure 13-30 Flow Calibration, Surrogate Page Tab	13-24
Figure 13-31 Flow Calibration, Customer Tab	13-25
Figure 13-32 Mixed Gas Data Entry Form	13-27
Figure 13-33 Flow Cal, Mixed Gas, Customer Tab	13-27
Figure 13-34 Sensor Tuning	13-28
Figure 13-35 Flow Calibration, Validation Page	13-28
Figure 13-36 Flow Cal, Cert Sheet Preview Page	13-31
Figure 13-37 Flow Cal, Cert Sheet	13-32
Figure 13-38 Validation Tab when cal gas and process gas are different	13-33
Figure 13-39 Calibration, Pre-Cal Tab, GF40	13-34
Figure 13-40 Calibration, Calibration Tab, GF40	13-34
Figure 13-41 Calibration, Customer Page Tab, GF40	13-35
Figure 13-42 Calibration, Create Validation Page, GF40	13-35
Figure 13-43 Calibration, Validation Tab with Validation Page, GF40	13-36
Figure 13-44 Calibration, Validation Tab, Validation Page with Data, GF40	13-36
Figure 13-45 Cert Sheet Report Window	13-37
Figure 13-46 Device Label Report Window	13-38
Figure 13-47 Warp (GP200)	13-39

Figure 13-48 Warp (GF)	13-40
Figure 13-49 Bin Select (GF) Window	13-41
Figure 13-50 Pressure Calibration Window, Cal Setup Tab Shown	13-41
Figure 13-51 Pressure Calibration, Orifice Tab	13-43
Figure 13-52 Pressure Calibration, Calibration Tab	13-43
Figure 13-53 Pressure Sensor Zero, High Point	13-45
Figure 13-54 Pressure Sensor Zero, Low Point	13-46
Figure 13-55 Pressure Calibration, Calibration Tab	13-47
Figure 13-56 Pressure Calibration, Linearization Page Tab	13-48
Figure 13-57 Pressure Calibration, Customer Page Tab	13-48
Figure 13-58 Pressure Calibration, Validation Tab	13-49
Figure 13-59 Pressure Calibration, Cert Sheet Options Window	13-51
Figure 13-60 Pressure Calibration, Cert Sheet Preview Window	13-52
Figure 13-61 Pressure Page Window	13-53
Figure 13-62 Flow Response Tuning Setup Window	13-54
Figure 13-63 Pressure Response Tuning Setup Window	13-55
Figure 13-64 Flow Valve Tuning Operation	13-56
Figure 13-65 Valve Tuning, Kp Value Too High, or Ki Too Low	13-56
Figure 13-66 Valve Tuning, Kp and Ki Values Too Low	13-57
Figure 13-67 Original PID Settings	13-57
Figure 13-68 Valve Tuning, Increase Kp Value	13-58
Figure 13-69 Valve Tuning, Overshoot	13-58
Figure 13-70 Pressure Valve Tuning, Default Values	13-59
Figure 13-71 Pressure Valve Tuning, Cycle Settings	13-60
Figure 13-72 Pressure Valve Tuning, Kp Low	13-60
Figure 13-73 Pressure Valve Tuning, Ki Low	13-61
Figure 13-74 Pressure Valve Tuning, Correct Kp and Ki Values	13-61
Figure 13-75 Anti-windup for a Normally Closed Valve	13-62
Figure 13-76 Anti-windup for a Normally Open Valve	13-62
Figure 13-77 Top Label	13-63
Figure 13-78 Print Top Label Window	13-64

Tables

Table 1-1 Device Model Families Supported in BEST	1-2
Table 2-1 Connector Types	2-1
Table 2-2 Available Brooks Instrument Cable Kit Options	2-3
Table 2-3 System Requirements	2-4
Table 2-4 Pro Features Requiring a License for SLA Rev B Products	2-4
Table 2-5 Pro Features Requiring a License for PC115/125 Products	2-5
Table 2-6 Pro Features Requiring a License for VDM300 Products	2-6
Table 2-7 Pro Features Requiring a License for GF40 Products	2-7
Table 2-8 Pro Features Requiring a License for GP200 Products	2-8
Table 2-9 Pro Features Requiring a License for GF1xx Products	2-9
Table 2-10 Pro Features Requiring a License for Quantim C Products	2-10
Table 2-11 Pro Features Requiring a License for GF80 Products	2-11
Table 2-12 FloCom Recommended Versions Installed with BEST 5.12	2-13
Table 11-1 S-Protocol Configuration Parameters	11-12
Table 11-2 DeviceNet Configuration Parameters	11-13
Table 11-3 Event Conditions for Which Alarms/Warnings Can Be Set (SLA)	11-17
Table 13-1 Biotech Gas Page Restrictions	13-26

Chapter 1 Introduction

1.1 Description

The Brooks' Expert Support Tool is a Windows®-based application that provides expanded monitoring & control of the Brooks' digital thermal mass flow controller/meter, flow controller/meter, pressure controller and remote pressure transducer (RT), and pressure-based flow controller modes for servicing tasks that include setup, configuration, calibration, tuning, control, monitoring, and troubleshooting. For device troubleshooting information, refer also to the device's Installation and Operations Manual.

Use of some features requires a Pro software license which is obtainable on a subscription basis. Contact Brooks Instrument to obtain a license. See [Table 2-4](#) through [Table 2-9](#) for a list of which features require a license.

Note that this user manual covers only the use of BEST with SLA Rev B ("Enhanced"), PC1xx, VDM300, GF40, GF1xx, and GP200 devices. BEST also supports SLA Rev A ("Legacy") and Quantim B devices. Those products are covered by a separate BEST user manual for those products.

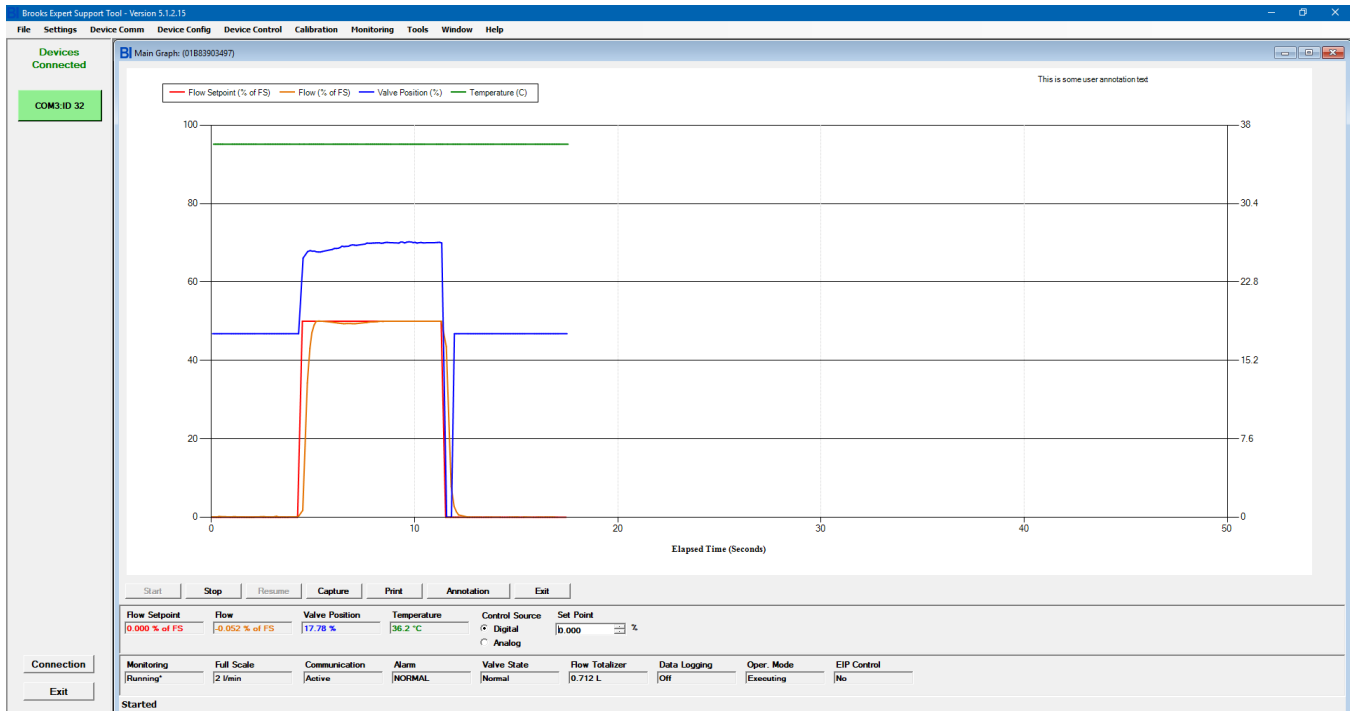

Figure 1-1 BEST Main Screen

Note that the Brooks Expert Support Tool is meant to be used as a startup and troubleshooting tool. It is not intended to be permanently connected to the device in your system/application.

See [Table 1-1](#) for all product models supported by BEST.

Table 1-1 Device Model Families Supported in BEST

Model Code	Device Type	Description
SLA58**	MFC/MFM/PC	Mass Flow Controller, Meter, Pressure Controller
SLA78**	MFC/MFM/PC	Mass Flow Controller, Meter, Pressure Controller
SLA79**	MFC/MFM/PC	Mass Flow Controller, Meter, Pressure Controller
SLAMF**	MFC/MFM	Mass Flow Controller, Meter
PC115	PC	Pressure Controller (Upstream or Downstream) ¹
PC125	PC	Pressure Controller (Downstream) with Flow Meter ¹
VDM300	MFC	DI Water Vapor Delivery Module
GF40	MFC	Thermal Mass Flow Controller
GF80	MFC	Thermal Mass Flow Controller
GF1xx	MFC	Thermal Mass Flow Controller ²
GF095	MFC	Thermal Mass Flow Controller
GP200	MFC	Pressure-based Flow Controller
Quantim B	MFC	Coriolis Mass Flow Controller ³
Quantim C	MFC	Coriolis Mass Flow Controller ⁴
SLA Rev A	MFC	Thermal Mass Flow Controller ³

1. DeviceNet Only
2. Includes GF095, GF100, GF101, GF120, GF121, GF125, GF126, GF135
3. See alternative user manual for Quantim B and SLA Rev A
4. Quantim C requires a newer version of FloCom/FloComPlus/FloCom database. See Table 2-11.

1.2 How to Use This Manual

It is recommended that you read the device Installation & Operations Manual (IOM) prior to reading this manual. Read this manual in its entirety before installing or using the Brooks Expert Support Tool.

Note that the illustrations of screens from BEST are illustrative – the exact appearance on your computer screen may vary slightly. Also, if software versions are shown on the illustrations, your versions may vary slightly.

Note: For device troubleshooting information, refer to the device’s Installation and Operations Manual.

1.3 Integrated Help

This user manual (which is searchable) can be accessed directly from the software, on the About->User Manual menu item. see [Section 5.2](#).

Chapter 2 Installation

This section describes the system requirements, how to install the BEST software onto a personal computer (PC), and how to connect the PC to the device.

2.1 Hardware Requirements

The hardware requirements are specific to each Brooks device.

Brooks devices will have one of two diagnostic port connections: 2.5 mm jack plug or Micro USB. See [Table 2-1](#).

Table 2-1 Connector Types

Device Model	2.5mm Jack Plug	Micro USB
SLA	X	
PC1x5	X	
VDM300		X
GF40	X	
GF1xx	X	
GF095		X
GP200		X
Quantim C	X	

The device is connected from its diagnostics port to a computer via the computer's serial port or USB port. Various cable/adaptor combinations are available to connect a device to the PC.

The following adapters and cables are typically examples required to connect a device with the 2.5mm jack plug diagnostic port to the computers standard serial port:

- RS232 to RS485 converter.
- Service port cable with 2.5-mm jack plug and 9-pin sub-D connector.

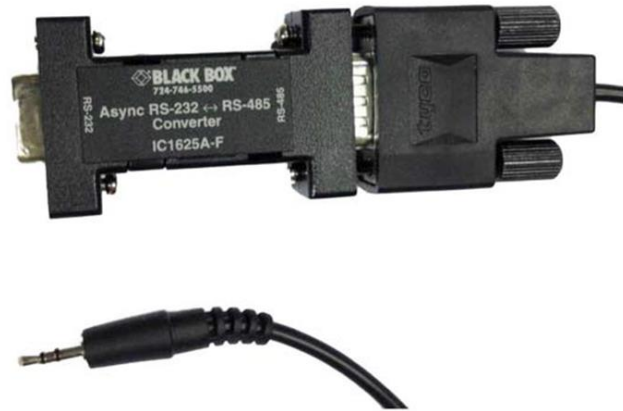

Figure 2-1 RS232 to RS485 Converter, cable
(2.5-mm jack plug to 9-pin sub-D conn.)

The following adapters and cables connect a device with the 2.5mm jack plug diagnostic port to the computer's standard USB port:

- USB to RS485 converter.
- Service port cable with 2.5-mm jack plug and 9-pin sub-D connector.



Figure 2-2 USB to RS485 Converter

Other adapter combinations may be possible.

This equipment may be purchased either along with the Brooks Expert Support Tool software or separately from Brooks Instrument. Contact the factory or your local representative for details.

Table 2-2 Available Brooks Instrument Cable Kit Options

Part Number	Description
778Z010ZZZ	Basic Cable Kit
A331710003	Cable Assembly 2.5mm
214F027AAA	USB-RS485 converter with DB-9 female
778Z012ZZZ	RS485 Analog/Profibus® Cable Kit w/Power Supply 24 Vdc
641Z117AAA	Power Supply 24 Vdc with DB-15 female
778Z013ZZZ	EtherCAT® Cable Kit w/Power Supply 24 Vdc
124Z170AAA	Cable, Power, EtherCAT to DB-15 male
778Z014ZZZ	DeviceNet™ Cable Kit w/Power Supply 24 Vdc
124Z171AAA	Cable, Power, DeviceNet to DB-15 male

The following tools and cables connect a device’s Micro USB diagnostic port the PC’s standard USB port:

- Standard USB to Micro USB cable



Figure 2-3 Standard USB to Micro USB cable

***NOTE:** No “license dongle” is required, but a software license is required for Pro features of BEST.

For device label printing, a label printer is required. All printer models are supported – the user is responsible for installing the printer manufacturer’s drivers as needed.

2.2 System Requirements

This section describes system and software requirements to use the Brooks Expert Support Tool application on a personal computer (PC).

The Brooks Expert Support Tool application can be installed on a Windows PC with the following requirements:

Table 2-3 System Requirements

Component	Minimum Requirements
Operating System	Microsoft Windows 10 Microsoft Windows 8 – BEST has not been formally tested with Windows 8 Microsoft Windows 7 – 32-bit/64-bit
COM Port	One dedicated serial port or USB port with USB to serial adapter, and RS232/RS485 adapter
Software License	Required for Pro Features (Calibration) See Table 2-4 to Table 2-9 for specifics

Table 2-4 Pro Features Requiring a License for SLA Rev B Products

Feature	Standard Version (No License)	Pro Version (License)
Connection	✓	✓
Terminal Commands	X	✓
View Device Info	✓	✓
Dump File	✓	✓
Wake Up State	✓	✓
Protocol Settings	✓	✓
Get Firmware Revision	✓	✓
Update Firmware	X	✓
Model Code Editing*	X	✓
Restrictor Selection	X	✓
Orifice Selection	X	✓
Meter Simulate MFC	X	✓
Reboot/Power Cycle	✓	✓
Control Source/Valve Control/Set Point	✓	✓
Graph/Basic Status/Meters	✓	✓
Warning Status	✓	✓
Alarm Status	✓	✓
User Totalizer	✓	✓
Data Logging	✓	✓
Sensor Zero	✓	✓
Create Gas Page	✓	✓
Pressure Application Instance	✓	✓
Response Tuning	✓	✓
Sensor Tuning	X	✓
Flow Calibration (MFC, MFM, RT devices)*	X	✓
Pressure Calibration (PC devices)	X	✓
Graph Settings	✓	✓
User Totalizer Settings	✓	✓
Warning Settings	✓	✓
Alarm Settings	✓	✓
Top Label Printing	✓	✓
Can Label Printing	X	✓

*Some restrictions exist for Biotech devices.

Table 2-5 Pro Features Requiring a License for PC115/125 Products

Feature	Standard Version (No License)	Pro Version (License)
Connection	✓	✓
Terminal Commands	X	✓
Device Info	✓	✓
Dump File	X	✓
Wake Up State	✓	✓
Protocol Settings	✓	✓
Get Firmware Revision	✓	✓
Update Firmware	X	✓
Reboot/Power Cycle	✓	✓
Control Source/Valve Control/Set Point	✓	✓
Graph/Basic Status/Meters	✓	✓
Warning Status	✓	✓
Alarm Status	✓	✓
User Totalizer	✓	✓
Data Logging	✓	✓
Sensor Zero	✓	✓
Create Gas Page	✓	✓
Tuning	✓	✓
Graph Settings	✓	✓
User Totalizer Settings	✓	✓
Warning Settings	✓	✓
Top Label Printing	✓	✓
Alarm Settings	✓	✓
Top Label Printing	✓	✓

Table 2-6 Pro Features Requiring a License for VDM300 Products

Feature	Standard Version (No License)	Pro Version (License)
Connection	✓	✓
Terminal Commands	✓	✓
Device Info	✓	✓
Dump File	✓	✓
Wake Up State	✓	✓
Protocol Settings	✓	✓
Get Firmware Revision	✓	✓
Update Firmware	✓	✓
Reboot/Power Cycle	✓	✓
Control Source/Valve Control/Set Point	✓	✓
Graph/Basic Status/Meters	✓	✓
Warning/Alarm Status	✓	✓
Alarm Status	✓	✓
Data Logging	✓	✓
Sensor Zero	✓	✓
Response Tuning	✓	✓
Graph Settings	✓	✓
Warning Settings	✓	✓
Alarm Settings	✓	✓
Calculators	✓	✓
Automated Dry-Down Operation	✓	✓

Table 2-7 Pro Features Requiring a License for GF40 Products

Feature	Standard Version (No License)	Pro Version (License)
Connection	✓	✓
Terminal Commands	X	✓
Device Info	✓	✓
Dump File	✓	✓
Wake Up State	✓	✓
Protocol Settings (S Protocol devices only)	✓	✓
Get Firmware Revision	✓	✓
Update Firmware	X	✓
Model Code Editing	X	✓
Meter Simulate MFC	X	✓
Reboot/Power Cycle	✓	✓
Control Source/Valve Control/Set Point	✓	✓
Graph/Basic Status/Meters	✓	✓
Alarm/Warning Status (RS485 devices only)	✓	✓
Alarm/Warning Settings (RS485 devices only)	✓	✓
Data Logging	✓	✓
Sensor Zero	✓	✓
Select Active Gas Page	✓	✓
Create Gas Page	✓	✓
Tuning	✓	✓
Analog I/O Calibration	✓	✓
Flow Calibration	X	✓
Device WARP	X	✓
Graph Settings	✓	✓
Top Label Printing	✓	✓
Can Label Printing	X	✓

Table 2-8 Pro Features Requiring a License for GP200 Products

Feature	Standard Version (No License)	Pro Version (License)
Connection	✓	✓
Terminal Commands	✓	✓
Device Info	✓	✓
Dump File	✓	✓
Wake Up State	✓	✓
Protocol Settings	✓	✓
Get Firmware Revision	✓	✓
Model Code Editing	X	X
Update Firmware	✓	✓
Reboot/Power Cycle	✓	✓
Control Source/Valve Control/Setpoint	✓	✓
Graph/Basic Status/Meters	✓	✓
Warning Status	✓	✓
Alarm Status	✓	✓
User Totalizer	✓	✓
Data Logging	✓	✓
Sensor Zero	✓	✓
Create Gas Page	✓	✓
Graph Settings	✓	✓
User Totalizer Settings	✓	✓
Warning Settings	✓	✓
Alarm Settings	✓	✓
Top Label Printing	✓	✓
Flow Calibration	X	X
Device WARP	✓	✓
Top Label Printing	✓	✓

Table 2-9 Pro Features Requiring a License for GF1xx Products

Feature	Standard Version (No License)	Pro Version (License)
Connection	✓	✓
Terminal Commands	✓	✓
Device Info	✓	✓
Dump File	✓	✓
Wake Up State	✓	✓
Protocol Settings	✓	✓
Get Firmware Revision	✓	✓
Update Firmware	✓	✓
Model Code Editing	X	X
Meter Simulate MFC	✓	✓
Reboot/Power Cycle	✓	✓
Control Source/Valve Control/Set Point	✓	✓
Graph/Basic Status/Meters	✓	✓
Alarm/Warning Status	✓	✓
Alarm Status	✓	✓
Data Logging	✓	✓
Sensor Zero	✓	✓
Select Active Gas Page	✓	✓
Create Gas Page	✓	✓
Tuning	✓	✓
Flow Calibration	X	X
Flow Validation	✓	✓
Device WARP	✓	✓
Graph Settings	✓	✓
Alarm/Warning Settings	✓	✓
Top Label Printing	✓	✓
Can Label Printing	X	X

Table 2-10 Pro Features Requiring a License for Quantim C Products

Feature for QMC	Standard Version (No License)	Pro Version (License)
Connection	✓	✓
Terminal Commands	X	✓
Device Info	✓	✓
Dump File	✓	✓
Wake Up State (power-up attribute values)	✓	✓
Protocol Settings	✓	✓
Get Firmware Revision	✓	✓
Update Firmware	X	✓
Reboot/Power Cycle	✓	✓
Control Source/Valve Control/Setpoint	✓	✓
Graph/Basic Status/Meters	✓	✓
Warning Status	✓	✓
Alarm Status	✓	✓
User Totalizer	✓	✓
Data Logging	✓	✓
Sensor Zero	✓	✓
Firmware Updating	X	X
Graph Settings	✓	✓
User Totalizer Settings	✓	✓
Warning Settings	✓	✓
Alarm Settings	✓	✓
Label Printing	✓	✓

Table 2-11 Pro Features Requiring a License for GF80 Products

Feature	Standard Version (No License)	Pro Version (License)
Connection	✓	✓
Terminal Commands	X	✓
Device Info	✓	✓
Dump File	✓	✓
Wake Up State	✓	✓
Protocol Settings (S Protocol devices only)	✓	✓
Get Firmware Revision	✓	✓
Update Firmware	X	✓
Model Code Editing	X	✓ ¹
Meter Simulate MFC	X	✓
Reboot/Power Cycle	✓	✓
Control Source/Valve Control/Set Point	✓	✓
Graph/Basic Status Monitoring	✓	✓
Alarm/Warning Status (RS485, Profibus devices only)	✓	✓ ¹
Alarm/Warning Settings (RS485, Profibus devices only)	✓	✓ ¹
Data Logging	✓	✓
Sensor Zero	✓	✓
Select Active Gas Page	✓	✓
Create Gas Page	✓	✓
Response Tuning	✓	✓
Analog I/O Calibration (RS485, Profibus devices only)	✓	✓
Flow Calibration	X	X
Device WARP	X	✓
Graph Settings	✓	✓
Top Label Printing	✓	✓

1. MFC726 only.

2.3 Installing the Brooks Expert Support Tool Application

This section describes how to install the Brooks Expert Support Tool application onto a personal computer (PC).

Uninstallation of existing versions of BEST prior to installation is not required, but recommended. See [Section 2.5](#) for more details about uninstallation.

To install the Brooks Expert Support Tool application, download the BEST installer file from the Products/Software section of the Brooks Instrument website (<https://www.brooksinstrument.com/en/products/accessories-software/product-software>). Once the installation file is downloaded, decompress if necessary.

Before installing, open and read the Readme file for last-minute updates and helpful notes that may not be included in this user manual.

Before starting the BEST installer, it is recommended to disconnect or power down any mass flow devices connected to the computer's serial ports or USB ports.

Run the setup.exe file - it is recommended to run this file as an administrator. Right click on the file and a pop-up menu appears. (See Figure 2-4). Click "Run as administrator."

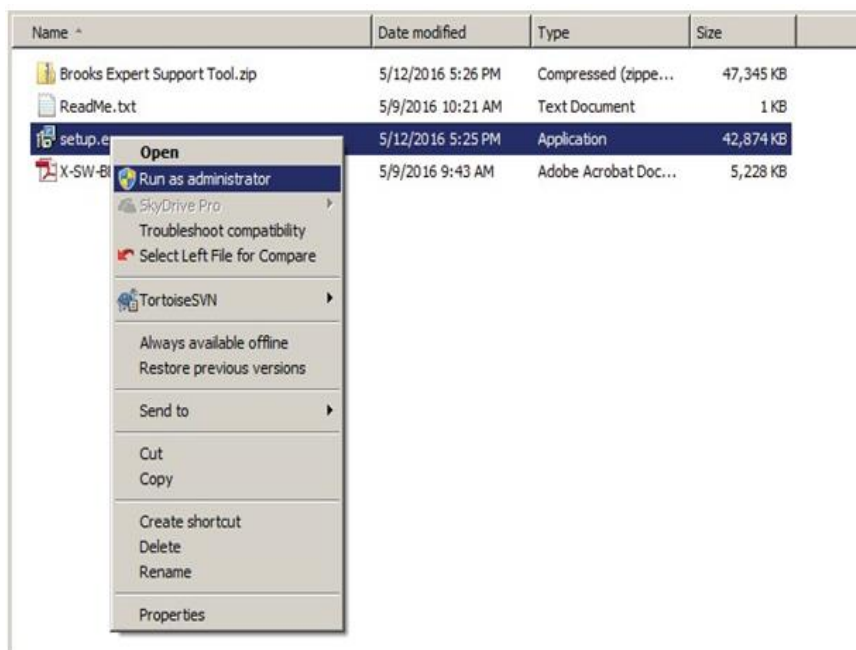

Figure 2-4 Running Setup.exe as an Admin

Next, follow the installation instructions provided by the software. It is strongly recommended to install BEST and its components in the default folders provided by the installer.

The installer will install BEST and its required software components, including versions of FloCom, FloComPlus and the FloCom databases.

For users who require a specific version of the FloCom database component, during the installation, the user will be presented with a software component selection menu (See Figure 2-5). Uncheck the item FloCom Databases to preserve the currently installed version and not install the version from the installer.

***NOTE:** BEST requires certain versions of FloCom, FloComPlus, and FloCom database be installed for maximum functionality. If you do not install the database version from the installer you must ensure that the desired version of FloCom database is installed separately from the BEST installer.

Table 2-12 FloCom Recommended Versions Installed with BEST 5.12

Program	Required Version
FloCom	4.20
FloComPlus	1.48 ¹
FloCom Database	20220418

- Quantim C products require a newer versions of these software items (when Quantim C is released). Check website for releases:

<https://www.brooksinstrument.com/en/products/accessories-software/product-software>.

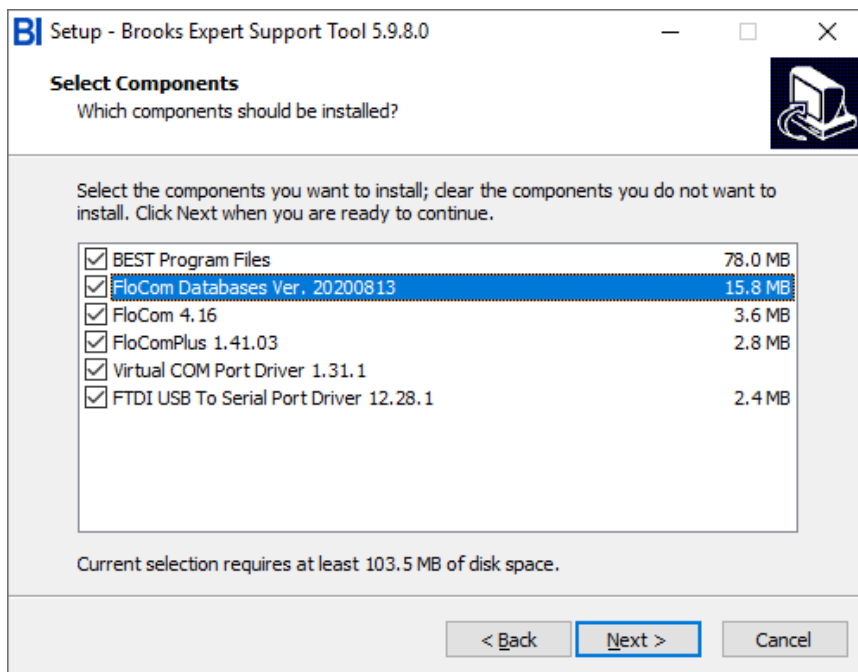

Figure 2-5 Installer Software Component Menu
 (Your versions may vary)

Virtual COM Port Driver: To use BEST with the VDM300 device it is necessary to install the virtual COM port (serial port/USB) driver. This driver is normally installed via the BEST installer. Make sure that the Virtual COM Port Driver check box is checked (see Figure 2-5).

See also the ReadMe file for more information about the Virtual COM port driver.

USB to Serial Port Driver: To use BEST with the USB to RS485 adapter, this driver is needed.

During installation, if it is installing a software component that already exists, the installer may present you with the options of Modify, Repair, or Remove, or similar: typically, choose repair. If it presents you with the options Complete or Custom, choose Complete.

The installer will optionally create an item in the Brooks Instrument program group and a shortcut icon on the Windows desktop.

Upon completion of installation, a software license must also be installed for access to Pro features of BEST. Contact Brooks Instrument to obtain a license. License installation instructions are covered in Section 5.1.2.

2.4 License Installation

To obtain a license, the user must contact Brooks Instrument to obtain a yearly license subscription. The user will receive a license key (a number), then enter it in the License Key text block (see Figure 2-6).

***NOTE:** After receiving your license key, store it in a secure location (backed up and secure from unauthorized use) for later retrieval.

Normally, the license installation process requires an Internet connection. A license can be installed without an Internet connection – contact Brooks Instrument for details.

To install a license, click on the menu Help->License->Install License. The window in Figure 2-6 will appear.

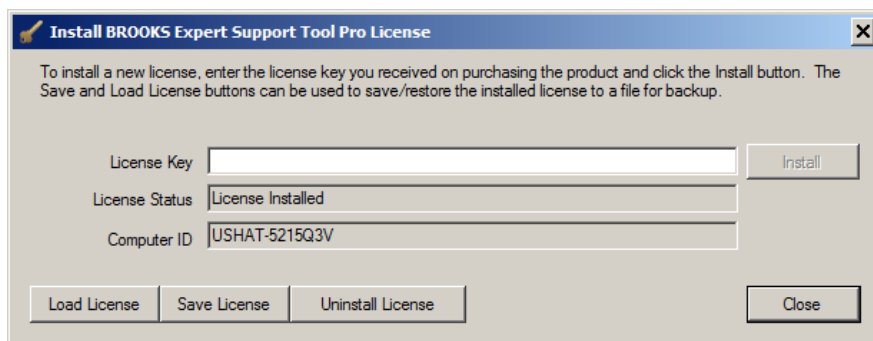

Figure 2-6 License Installation Window

Copy and paste your license key text into the License Key text box. Then click Install. The software will attempt to use an Internet connection to contact Brooks Instrument to verify the license. Then the license will be installed on the local computer. You will receive a message when it is finished. To view the installed license, click the menu item Help->License->Info. See also [Section 5.1.1](#).

4. Connect the desired power cable to the device and to the power source. Reference the device manual.
5. Verify that the device is powered on and the MOD LED is solid green or flashing red.



Figure 2-8 RS232 to RS485 Connection

For Brooks devices utilizing a Micro USB port, connect a standard USB to Micro USB cable between the computer's USB port and the device's Micro USB diagnostic port.



Figure 2-9 Typical Diagnostics Port Connection (SLA Rev B Model shown)



Figure 2-10 Typical Diagnostics Port Connection (Pc1xx Model shown)



Figure 2-11 Micro USB Diagnostic Port (VDM300 model shown)

2.7 Disconnecting the PC from the Device

When you are done using the Brooks Expert Support Tool, you should disconnect the computer from the device.

To disconnect the computer from the device's service port:

1. Detach from the device using the software Connection Window.
2. Exit from the Brooks Expert Support Tool software, optionally.
3. Disconnect the cable between the computer and device.

Chapter 3 Basic Operations

This section gives a general introduction to the basic operation of BEST, including starting BEST, the main screen, establishing communications with a device, viewing the main graph window, detaching from a device, and the menus.

3.1 Main Screen

To start BEST, select BEST from your **Start** menu, or double-click its application shortcut. The main window displays, with no devices connected.

Title Bar->
Menu Bar->

Devices Panel->

Status Bar->

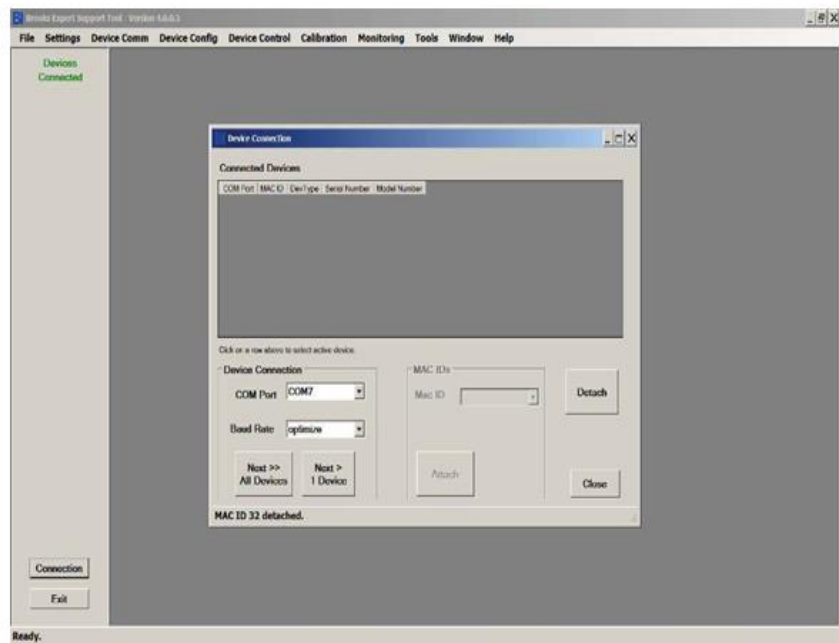

Figure 3-1 Main Screen with Device Connection Window

The **Title Bar** shows the name and current version of the software. The title bar can also be used to select, move, and maximize the window, according to Windows conventions.

The **Menu Bar** is where most functionality of BEST is accessed. BEST windows are opened from the menu bar. Menu items are typically accessed from left to right and top to bottom.

The BEST desktop is where all opened BEST windows exist. This is similar to the Windows desktop, except that this desktop contains only BEST windows. See also [Chapter 6](#).

The **Status Bar** shows useful instructions and messages about the current status of the software and its processes.

If the user is using dual monitors, the user may gain additional space for windows by dragging the side edge of main screen across to the additional monitor.

When the software first starts, it shows the device connection window in the center of the screen. To use most features of BEST, you must first “attach” (or establish communication with) a device using the device connection window. see [Section 10.1](#) for more details about the Connection Window.

3.2 Attaching to a Device

The first thing to do is to establish communications with (or “attach” to) a device.

When BEST software starts, no devices are attached. Devices are attached via the device connection window. For convenience, the software opens the device connection window for you upon startup.

First, in the Device Connection/COM Port drop-down list (See [Figure 3-2](#)), select the COM Port you are using to connect to your device.

Next, select the desired Baud rate from the Device Connection->Baud rate drop-down list. Most users will choose Optimize, which will automatically select the fastest baud rate that successfully communicates with the device. if you have trouble attaching to a device, you can try a lower baud rate to troubleshoot. Your selected port and baud rate selections will be retained by BEST for your convenience.

Click the **Next > 1 Device** button to find the connected MAC address. After a few moments, if a device is located, its MAC ID (or “address”) is listed in the Mac ID drop-down list.

Once a device’s MAC ID is located, click on the Attach button. After a few moments, if it is attached, a row appears in the connected devices box, as shown in [Figure 3-2](#).

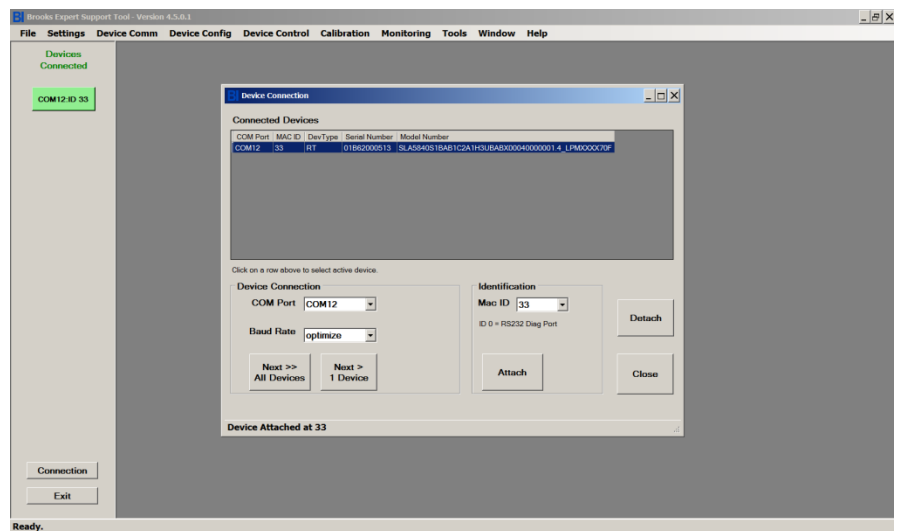

Figure 3-2 Device Connection Window, Device Attached

Once the device is attached, close the Device Connection window.

For some device types, a window will then pop up asking if you want to place the device in the executing state.

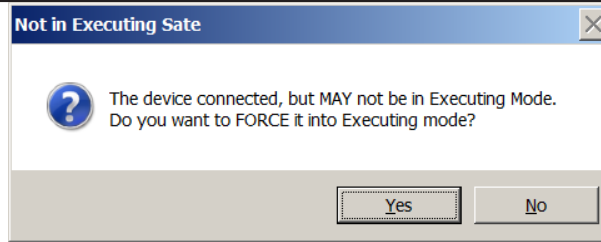

Figure 3-3 Executing Mode Window

If you need to control the device's setpoint or valve with BEST, click Yes.

Once the device is attached, close the Device Connection window.

Likewise, when detaching from a device, it may ask you if you want to place the device in the idle state or SafeState.

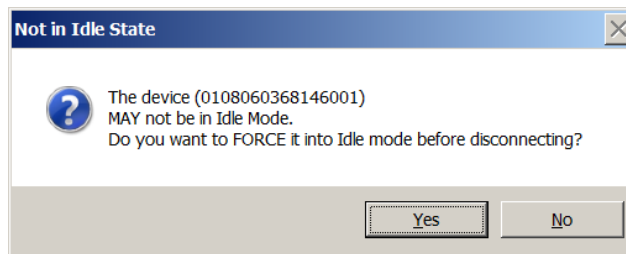

Figure 3-4 Idle Mode Window

See also [Section 10.1](#) for more details about device connections.

3.3 Main Graph

Once a device is attached, you can run the main graph to monitor the behavior of the device. Click on the green button in the upper left corner of the Devices Connected block. The main graph window will open, then Click Start.

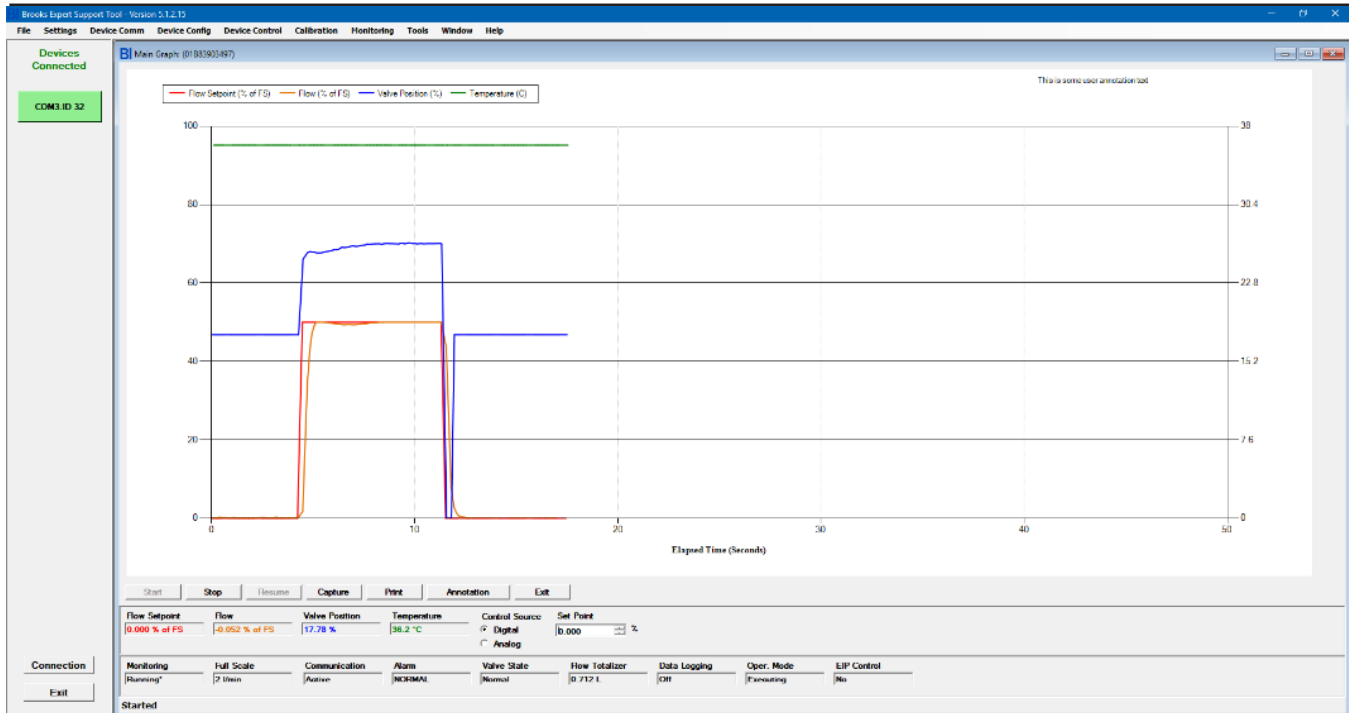

Figure 3-5 Graph Window

see [Section 8.4](#) for more details about the graph window.

3.4 Closing the Session with the Device and Exiting BEST

To close the communication session with a device and exit the software, open the File menu and choose Exit, or click the window's close button (the X in the upper right corner). Exiting the software automatically closes all communications with the device.

Alternatively, the user may close the communications with (or “detach” from) the device, by opening the Device Comm->Connection menu. Then click Detach. The user may attach to another device, if desired.

3.5 Brooks Expert Support Tool Conventions

The Brooks Expert Support Tool was designed to remain consistent with regard to how the user interacts with the application across all functions and features. It is also generally consistent with Windows user interface conventions.

The following text field conventions apply throughout the software:

- Text fields with a gray background display a read-only value (such as the Current Position (%) in Figure 3-6).
- Text fields with a white background are editable (such as Set Point Position (%) in Figure 3-6).

- Usually, editable text fields update the software or device either when the user clicks the Enter button, when the focus moves to another field by using the Tab key or mouse, or when a separate apply button is clicked (see each section in the manual for specific instructions).
- If a text box contains “NaN” or “n. def.” it means “Not a Number”, not defined, or invalid calculation result.

Many windows also require numeric input from the user. This type of window is also called a “form”. For numeric input, forms often feature numeric up/down controls. See Figure 3-6 for an example of a numeric up/down control (circled).

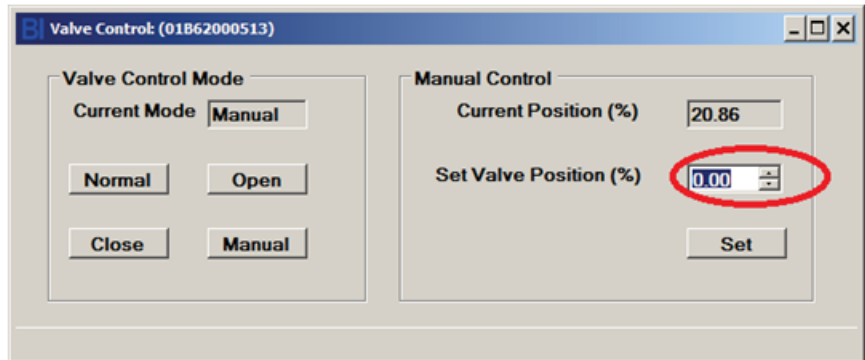

Figure 3-6 Example Numeric Up/Down Control

Up/down controls help prevent invalid numeric data entry. Click the up arrow to increment the numeric value, or the down arrow to decrement. Up/down controls also have maximum and minimum values. You may also type in a number directly, but it won't allow non-numeric entry. Also, in some cases, it won't accept the thousands separator character (for example, “,” in English culture). In most forms, you may also click enter to accept the entered value, or move the focus off the control to another control on the form.

Data Entry and International Locales: While BEST doesn't translate all words from the English language, BEST supports various number and date formats for data entry and display, according to the user's computer settings for that region (see Control Panel->Region and Language on your computer). BEST uses the user's Windows settings for region and locale for most numeric data, except where noted in this manual. For example, when entering a decimal number in English a user might type 1.234 into a text box, but for German culture, one would enter 1,234 because in that culture the comma is the decimal separator.

***NOTE:** In some BEST windows you must always enter English formatted numbers (because that is what the device expects). For example, in the terminal window, you must use English decimal number formats because the commands that a device accepts require English. In those types of windows, a statement will be present on the form as a reminder.

For most windows in BEST, for data entry, you must use the format of your region, except where noted. Likewise, most windows will display numbers in the format of your region, except where noted.

The sample illustrations in this manual are shown using the English region formatting.

3.6 Menu Bar

The **Menu Bar** (see Figure 3-1) is where most of the functionality of BEST is accessed. Most BEST windows are opened from the menu bar, and then those windows will exist on the BEST Desktop. Menu items are typically accessed from left to right and top to bottom.

Note that this manual shows all menu items. Certain menus may not appear if the features of those menus are not supported by the currently selected device.

Subsequent chapters of this manual describe each of the menus in detail.

Chapter 4 File Menu

The **File Menu Item** contains a place to exit the program. See Figure 4-1. (You may also exit the program via the “X” in the upper right of the title bar, according to Windows convention).

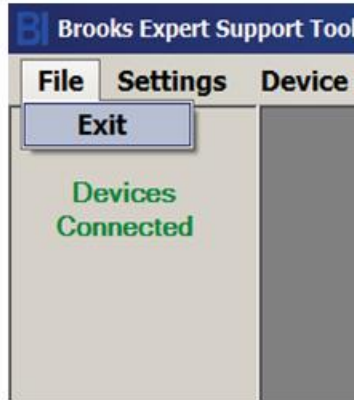

Figure 4-1 File->Exit Menu

Chapter 5 Help Menu Item

The **Help Menu Item** is where information about the BEST software can be accessed, including the current version of BEST, licensing options, and user help. A device connection is not required to access these menu items.

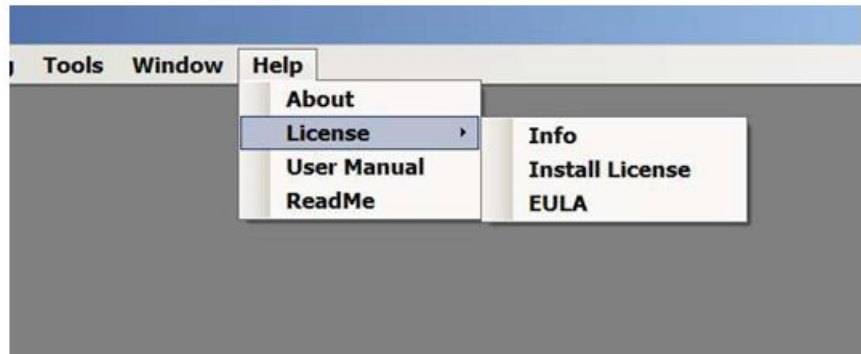

Figure 5-1 Help Menu

5.1 About Window

The **About-> About Menu Item** is where information about the current version of BEST and its software components can be viewed. Information provided includes the current version of BEST and its software components. (The current version of BEST is also always visible in the main window's title bar.)

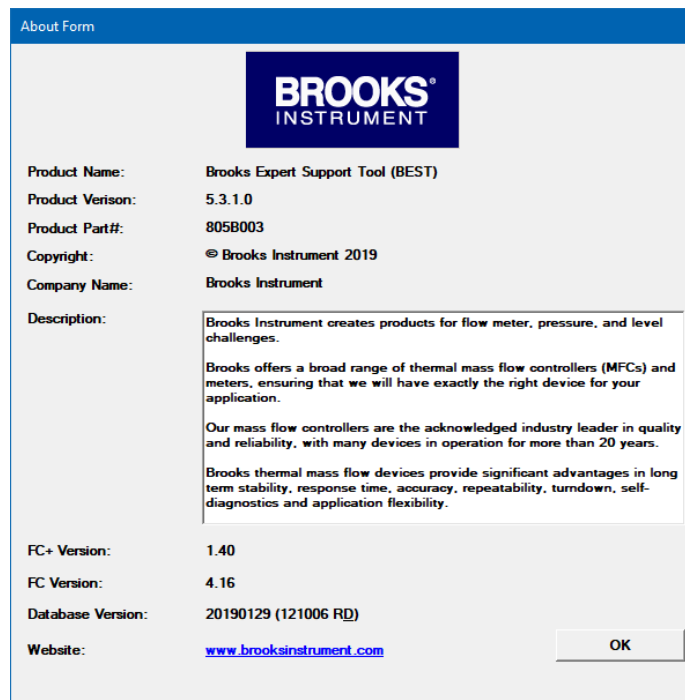

Figure 5-2 About Window
(Your versions may vary)

5.1.1 License Info Window

The **License Info Menu Item** is where information about installed licenses for the current version of BEST can be viewed (but not updated). The user may also set options about when to be reminded of license expiration.

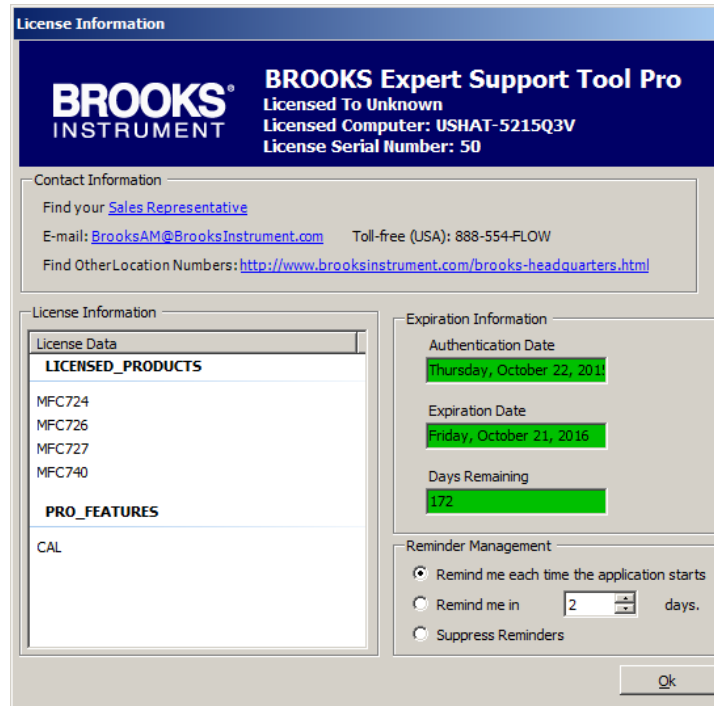

Figure 5-3 License Information Window
(Your data may vary)

5.1.2 Install License Window

The **Install License Menu Item** is where licenses may be installed (and uninstalled). The user must contact Brooks Instrument to obtain an annual license subscription, if desired. The user will receive a license key (a number), then enter it in the License Key text block.

*NOTE: After receiving your license key, store it in a safe location (backed up and secure from unauthorized use) for later retrieval.

Normally, the license installation process requires an Internet connection. A license can be installed without an Internet connection – contact Brooks Instrument for details.



Figure 5-4 License Install Window

5.1.3 EULA Window

The EULA is where the user may view the End User License Agreement (EULA).

5.2 User Manual Menu

This BEST user manual (which is searchable) can be accessible directly from the software under the Help->User Manual menu. A PDF file reader (such as Adobe Reader or Microsoft Edge) must be installed on the computer to read this file.

5.3 ReadMe Menu

The user may view last-minute updates (not included in this manual) as well as technical and useful troubleshooting information from this menu.

Chapter 6 Window Menu

The **Window Menu Item** is where BEST windows can be accessed and controlled.

BEST windows exist on the BEST desktop (see **Figure 3-1**). This is similar to the Windows desktop, except that the BEST desktop contains only BEST windows.

BEST windows are sized and closed in a similar way as in the Windows operating system. Most BEST windows can be sized, minimized, maximized, and restored. Some BEST windows have minimum and/or maximum sizes. Multiple windows may be opened with some exceptions. Some windows, such as calibration windows, when they are open, do not allow access to other windows until they are first closed. (These are called “modal” windows). A modal window cannot be minimized or maximized, but may be resized by dragging the sizing handle in the lower right corner of the window (if the windows is not maximized).

Note also that the title bar of each BEST window shows the serial number of the device associated with that window.

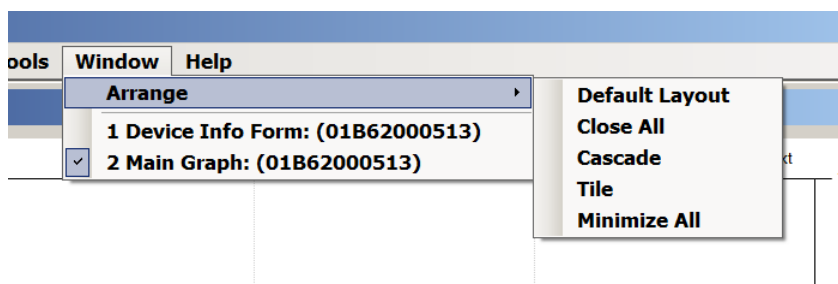

Figure 6-1 Window Menu

If any windows are open in the BEST desktop, they will be listed in the Window menu under the Arrange item (See **Figure 6-1**). Clicking on one of those items will activate that window.

The **Close All** Window menu item closes all windows (for all devices).

The **Cascade** Window menu item, arranges all open windows in a “cascade” arrangement from the upper left corner of the windows. See **Figure 6-2**.

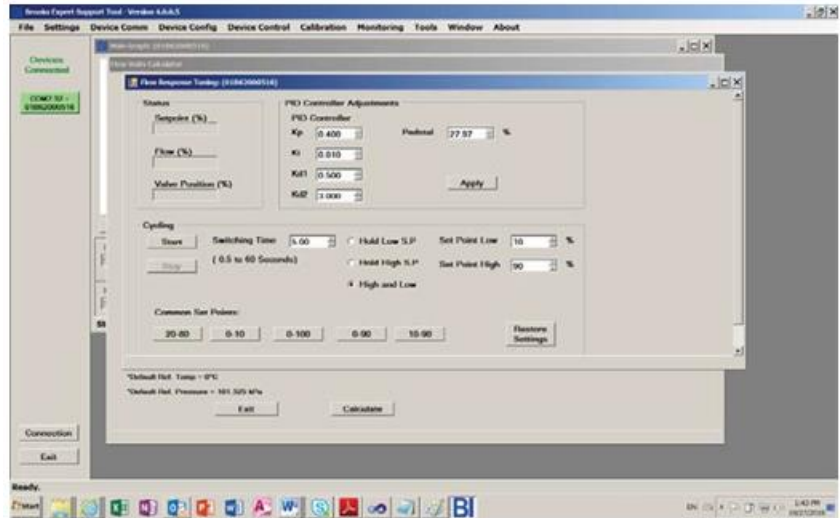

Figure 6-2 Cascaded Window Layout

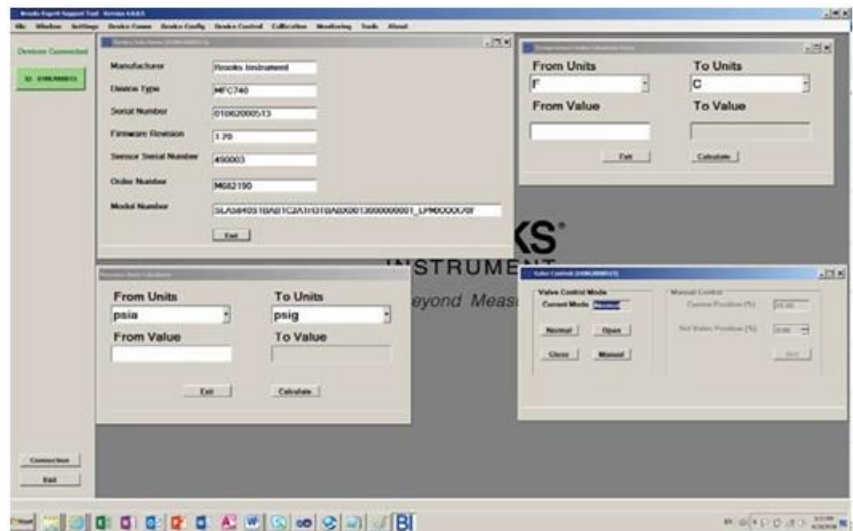

Figure 6-3 Tiled Window Layout

Tile will arrange all open windows in a “tiled” arrangement. See Figure 6-3.

Minimize All minimizes all windows to an icon representation. See Figure 6-4.

NOTE: If a modal window is minimized, it will disappear into an icon at the bottom of the screen. To restore it, click on the icon.

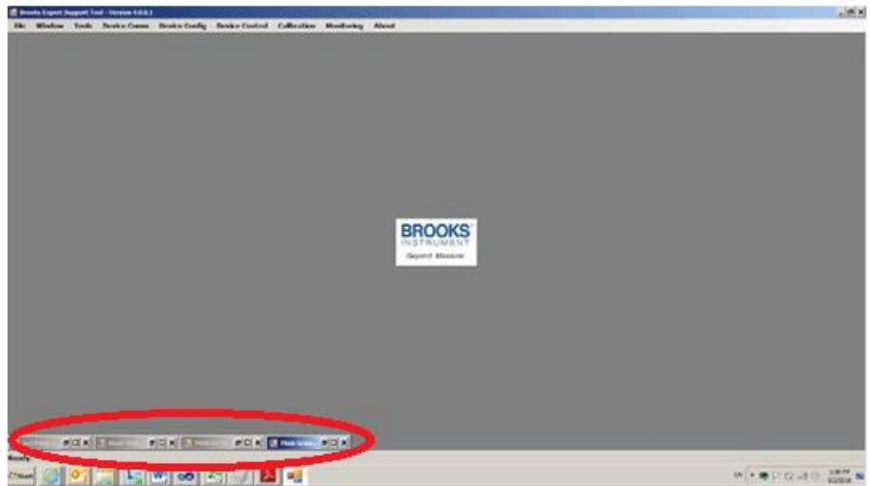

Figure 6-4 Minimized Windows

Chapter 7 Settings

The **Settings Menu Item** is where BEST software options can be changed to the user's preferences. These are software options, not device options. Most of the features in this menu do not require a device connection. Menu items shown depends on device type.

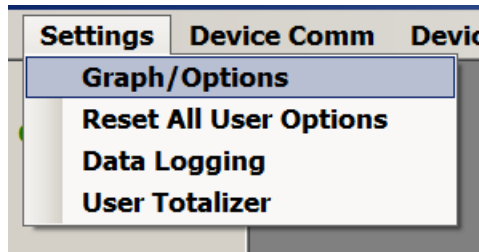

Figure 7-1 Settings Menu

7.1 Graph Options

The Graph Options is where the user can select options and preferences for the operation of the main graph window. Here the user can select preferences such as the data units, scaling, number of decimal places, and graph legend options. See Figure 7-2 for the Graph Options window.

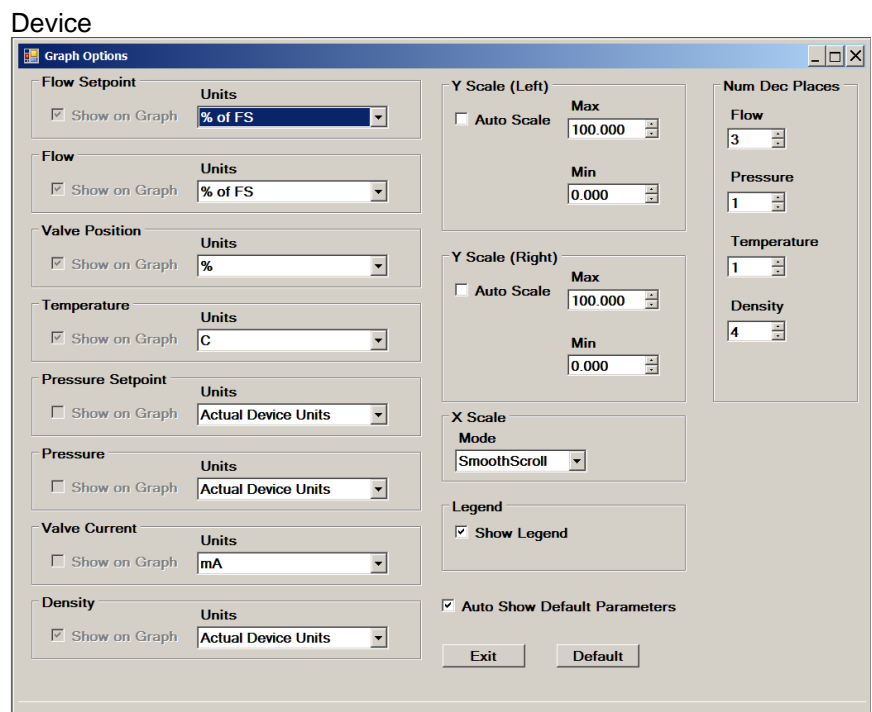

Figure 7-2 Graph Options Window

For each graph parameter, the user can choose which parameters to show on the graph, legend, and meters panel (see [Section 8.4](#) for more information on the meters panel of the main graph window).

The user can also choose to allow the software to determine which device parameters to show automatically by choosing to select **Auto Show Default Parameters**, in which case the software will show only the parameters relevant for the device type (for example, an MFC device will not show pressure or pressure setpoint). If **Auto Show Default Parameters** is checked, the individual parameters' **Show on Graph** check boxes will be disabled – if it is unchecked they will be enabled. For most usages, leave Auto Show Default Parameters checked.

***NOTE:** If you need a higher data sample rate on the main graph, such as with response tuning, uncheck the **Auto Show Default Parameters** check box and select only the parameters you need to view. Unchecking the Valve Position parameter can yield significant increases in sample rate.

For each parameter, the user can choose “device units” in which case the units stored in the device are automatically chosen for display.

The graph Y axis scaling for both the left side Y axis and the right side Y axis can be adjusted by the user. The left side axis is for flow, flow setpoint, pressure, and pressure setpoint. The right side axis is for valve position, valve current, temperature, and density.

The **Num Dec Places** block sets the number of decimal places displayed for numeric data across the software.

Valve current is for VDM300 devices only.

***NOTE:** For some parameters, changing graph settings while the graph is running may require the graph to be closed and re-opened for the changes to take effect.

7.2 Reset All User Options

Reset All User Options is where the user can reset all BEST software user settings to their factory default settings. Use with caution.

7.3 Data Logging Options

The **Data Logging Options Menu Item** is where the user can set preferences as to whether data from the main graph window is to be saved to file as it monitors. Check the check box Save Data To Log to save data to file. Files can be saved in either text or csv format. The file name will be created automatically. The folder is listed in the Data Log File Path text box. The user can also conveniently open saved files from the path by clicking a single button, the Open File button. See Figure 7-3 for the Data logging options window.

The data logging status (on or off) is shown at the bottom of the main graph window.

The user may also have some control over the sample rate (of both the graphical display and the recorded data). Under the units drop-down, select Maximum to obtain the maximum sample rate on your system. Otherwise, select SamplesPerSecond or SecondsPerSample, then set the Target rate. The target rate is not a guaranteed rate, nor is the rate guaranteed to be precise.

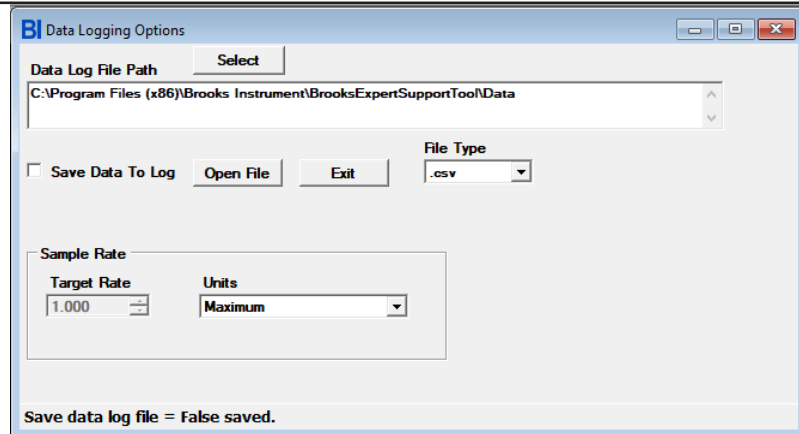

Figure 7-3 Data Logging Options

7.4 User Totalizer Options

For devices that support a totalizer, the User Totalizer Options Menu Item is where the user can set preferences for the user totalizer for devices that support a totalizer. (NOTE: the user totalizer is different than the device's hardware totalizer. See [Section 8.3](#) for details on the hardware and user totalizers). The user can set preferences as to how often to update the user totalizer window and can reset the user totalizer. See [Figure 7-4](#). The user totalizer units are always the same as the device's setting for totalizer units.

A device must be attached to see and use this window.

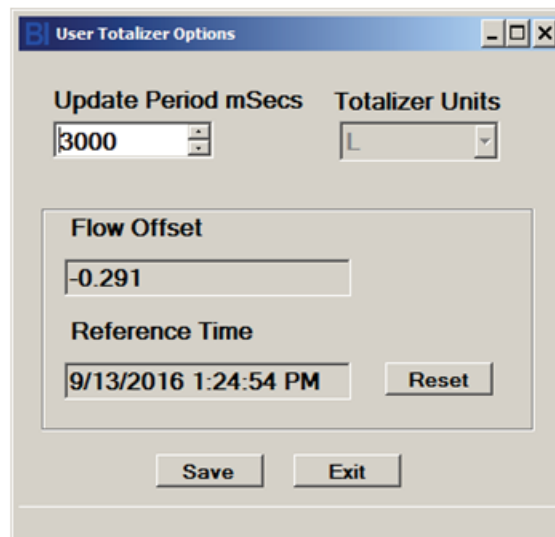

Figure 7-4 User Totalizer Options

7.4.1 User Totalizer Options

For SLA devices with EthernetIP digital I/O option, a different totalizer window is used.

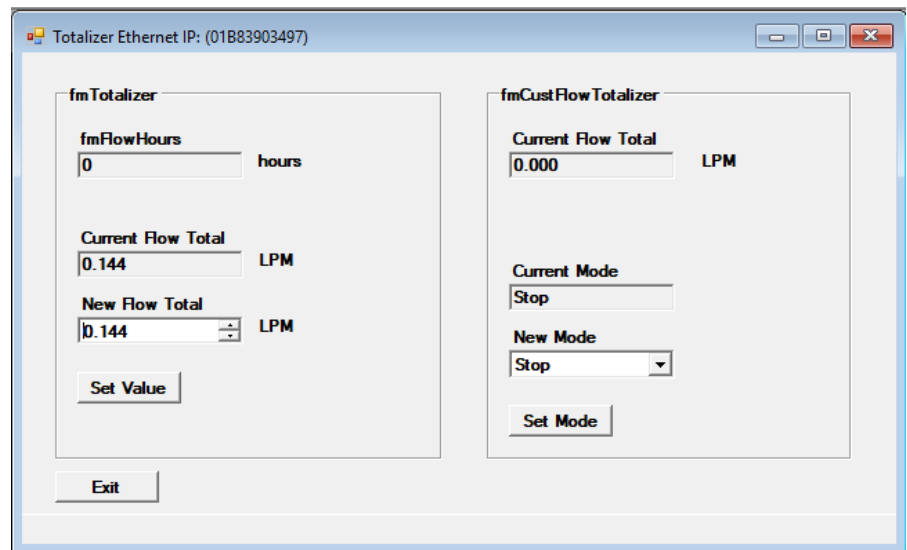

Figure 7-5 EthernetIP Totalizer

For the fmTotalizer, the user may set the total value to a specific value. Change the value in “New Flow Total” then click “Set Value”. The user may not change the fmFlowHours.

The user may also change the mode for the fmCustFlowTotalizer. To stop the totalizer, change the New Mode to Stop, then click Set Mode. To reset the totalizer, change the New Mode to Reset, then click Set Mode. To restart the totalizer, change the New Mode to Run, then click Set Mode.

Chapter 8 Monitoring Menu

The **Monitoring** menu gives the user the ability to monitor various aspects of the device. Each of the windows accessible through the Monitoring menu, when opened, shows a live status of various parameters of the device. This includes alarms, warnings, flow, pressure, control, and other status parameters.

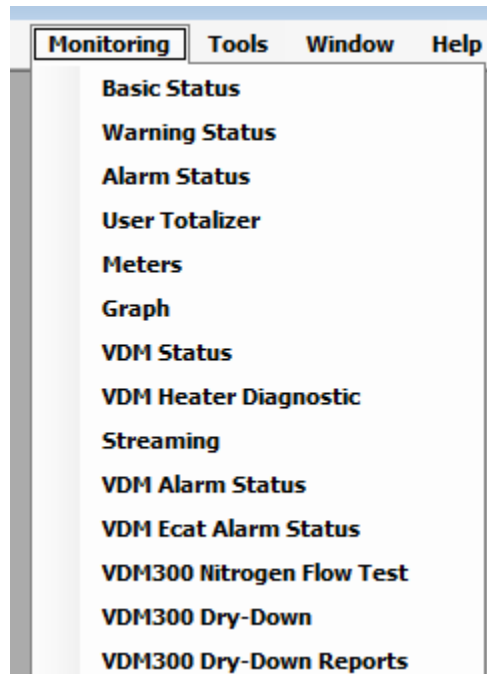

Figure 8-1 Monitoring Menu
(not all devices support all menus)

Except for the graph window ([Section 8.4](#)), and VDM300 DryDown Reports ([section 8.9](#)), these windows are monitoring as long as they are open. These windows update typically at about once per second. These windows are read-only windows and can access and display these parameters whether the device is in internal (digital) or external (analog) control mode.

Most Monitoring menu windows can be resized by using the mouse to grab an edge or corner of the window and dragging.

8.1 Warning Status

The Warning Status Window shows detailed warning states for supported devices interfaces/protocols. For some device types, the warning status is integrated with the alarm status window. The exact warnings shown may vary depending on the device type. The warning window for a flow controller is shown in [Figure 8-2](#).

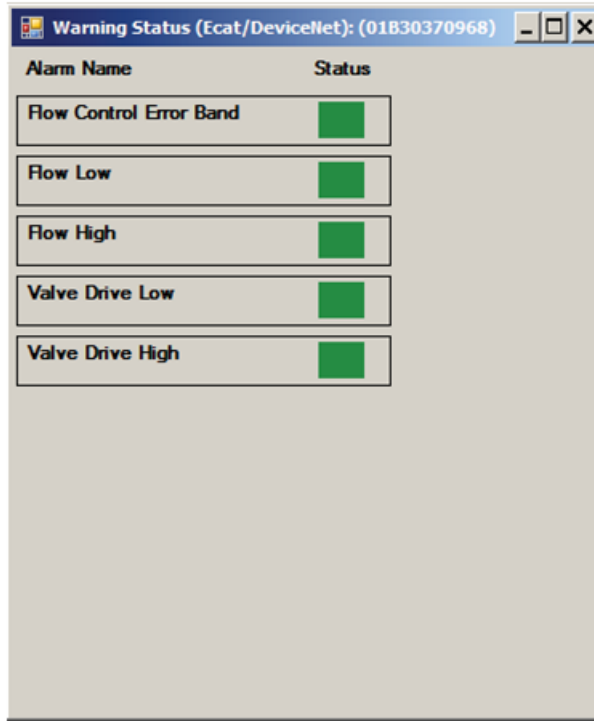

Figure 8-2 Warning Status Window
(Actual alarms may vary depending on device type)

For VDM300 devices, the VDM Warning Status Window shows detailed warning states for that device type in Figure 8-3.

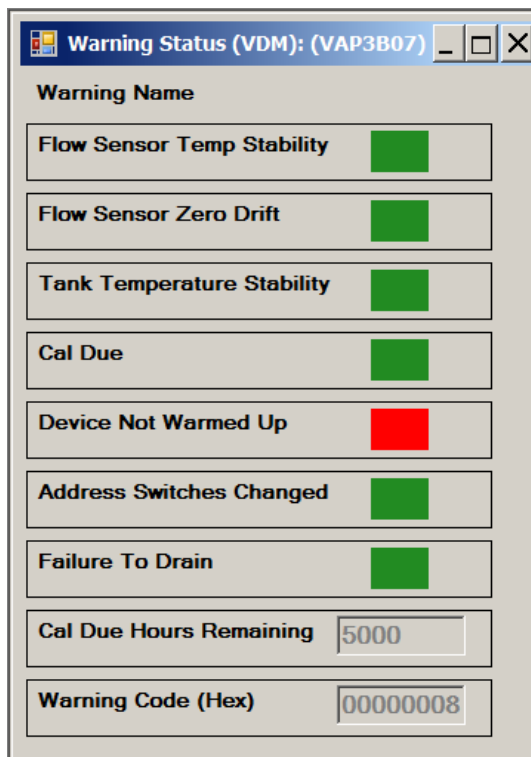

Figure 8-3 VDM Warning Status Window

8.2 Alarm Status

The **Alarm Status** window shows detailed alarm states for supported devices interfaces/protocols. The exact alarms/warnings shown may vary depending on the protocol type and device type. For SLA EthernetIP, GF40, and GP200 devices, the Alarm window also shows warnings. The alarm window for an SLA Rev B flow controller with RS485 interface is shown below in Figure 8-4. The alarm status window can be resized by dragging a corner or edge of the window.



Figure 8-4 Alarm Status Window (RS485)
 (Actual alarms may vary depending upon device type)

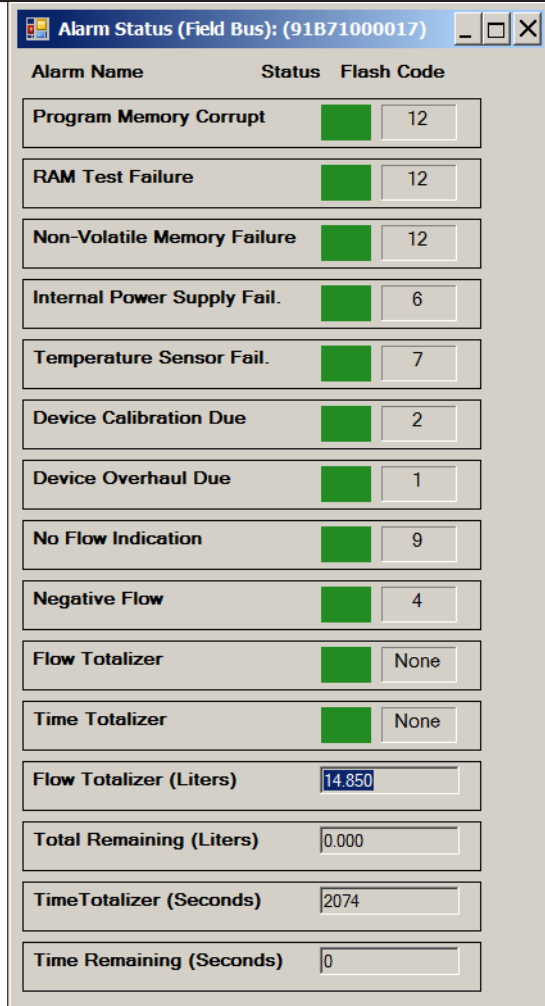

Figure 8-5 Alarm Status Window (FieldBus)

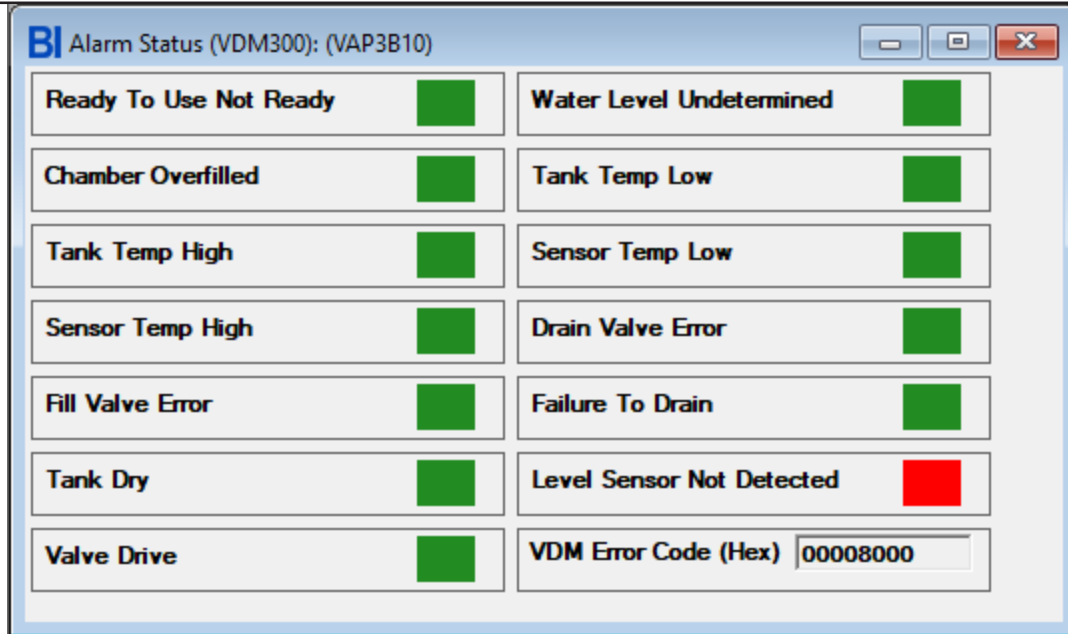

Figure 8-6 VDM Alarm Status Window

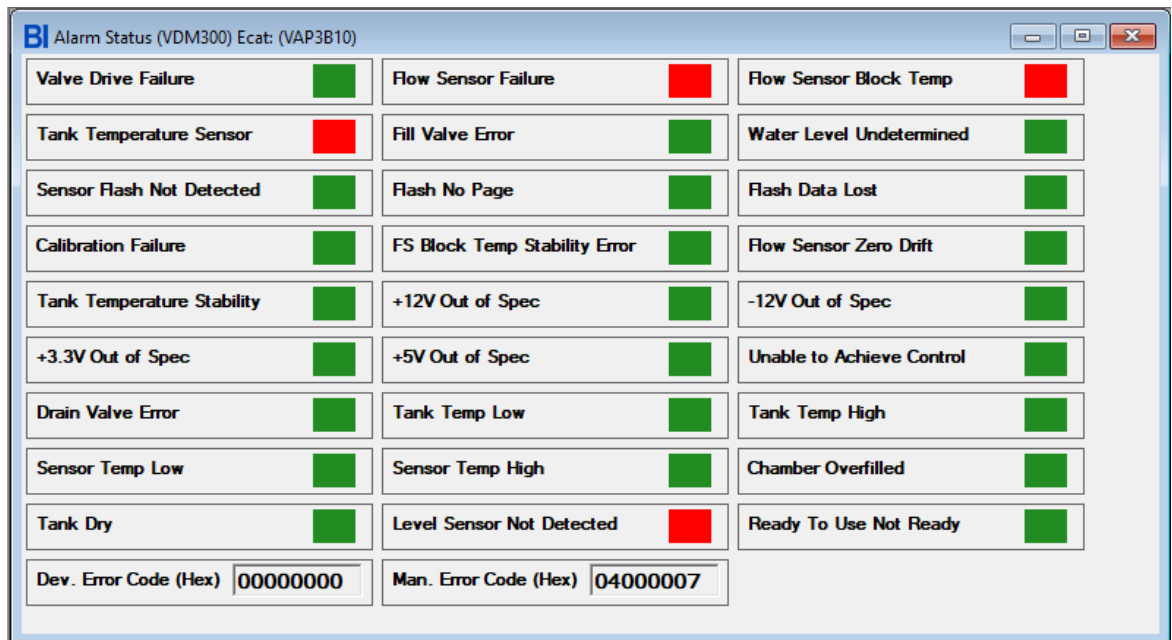

Figure 8-7 VDM Ethercat Alarm Status Window

Alarm Name	Status	Flash Code
Flow Limit 1 Low	Green	10
Flow Limit 1 High	Green	
Flow Limit 2 Low	Green	
Flow Limit 2 High	Green	11
Valve Drive Low	Green	3
Valve Drive High	Green	3
Setpoint Deviation	Green	8

Figure 8-8 GF40 Alarm Status

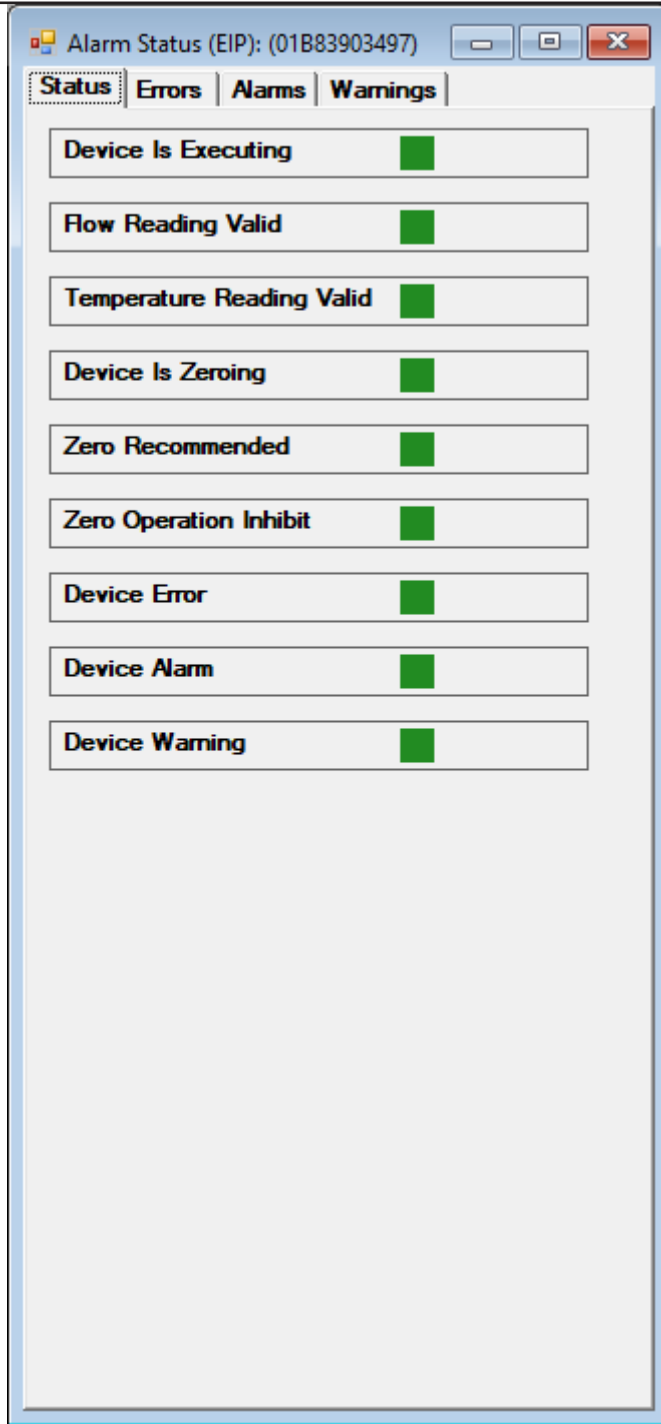

Figure 8-9 EthernetIP Alarm Status Window, Status Tab

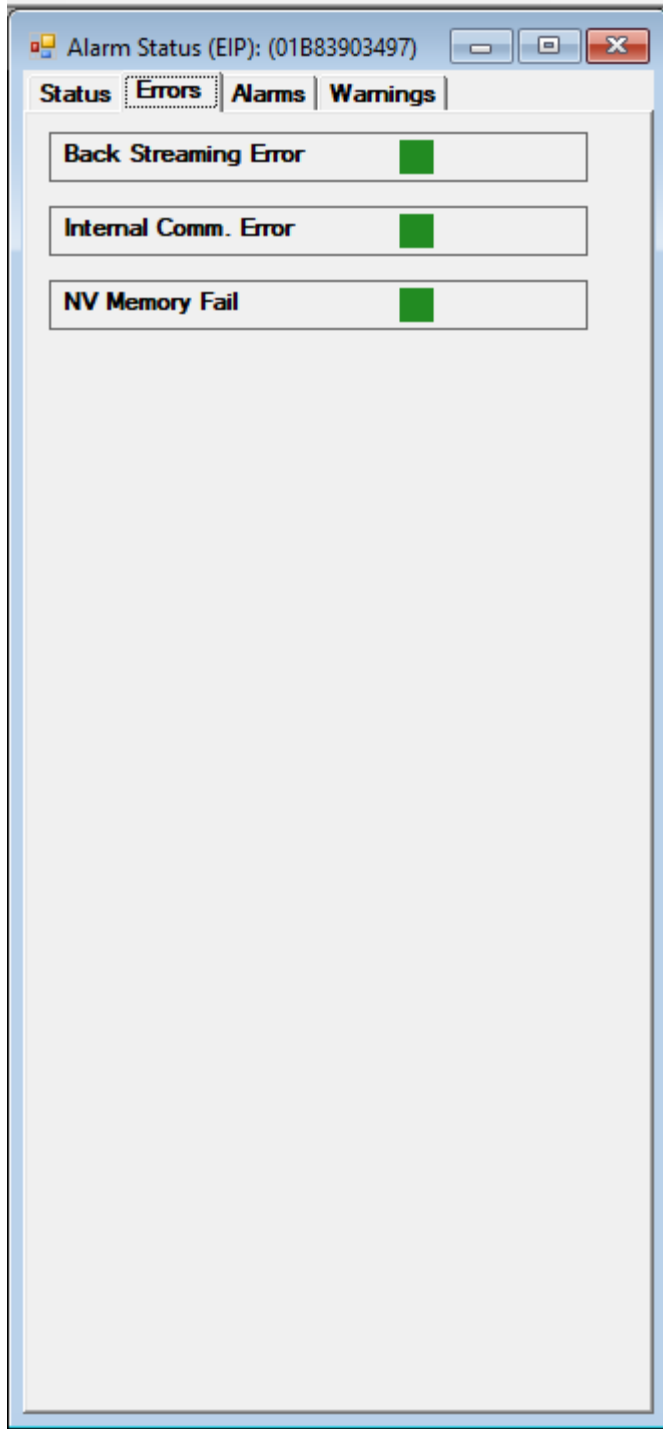

Figure 8-10 EthernetIP Alarm Status Window, Errors Tab

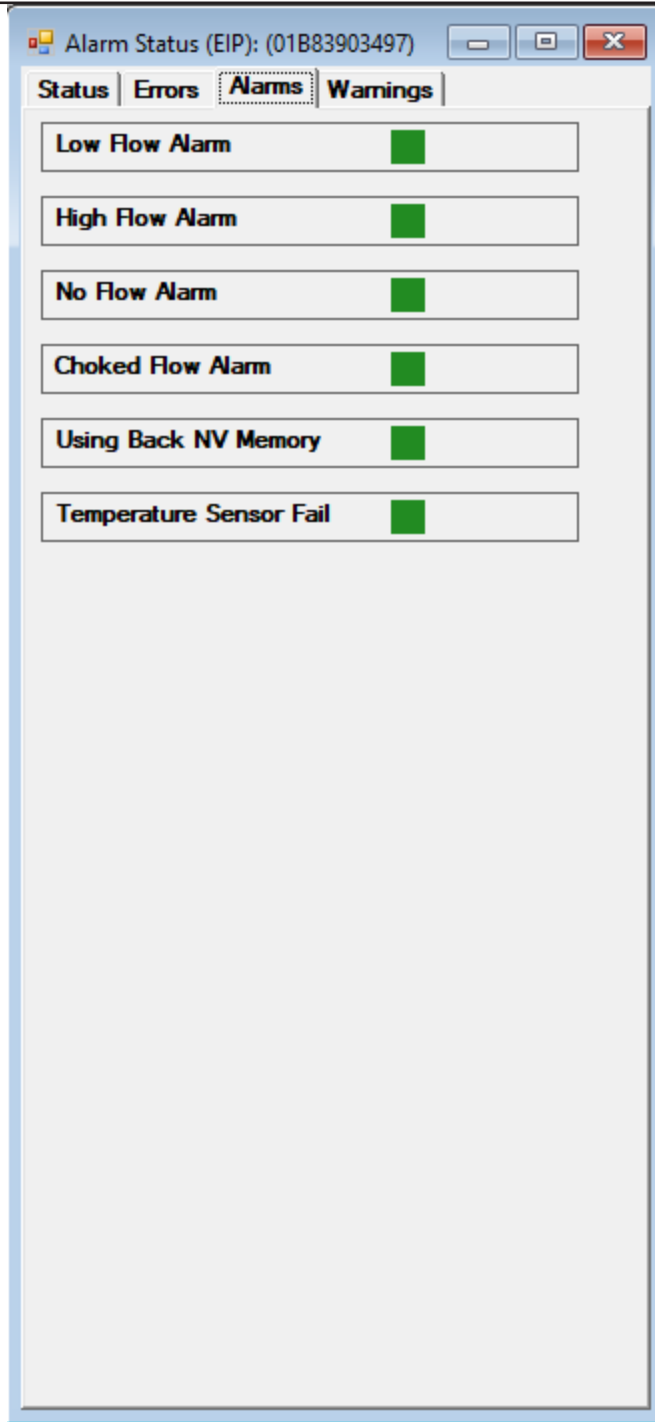

Figure 8-11 EthernetIP Alarm Status Window, Alarms Tab

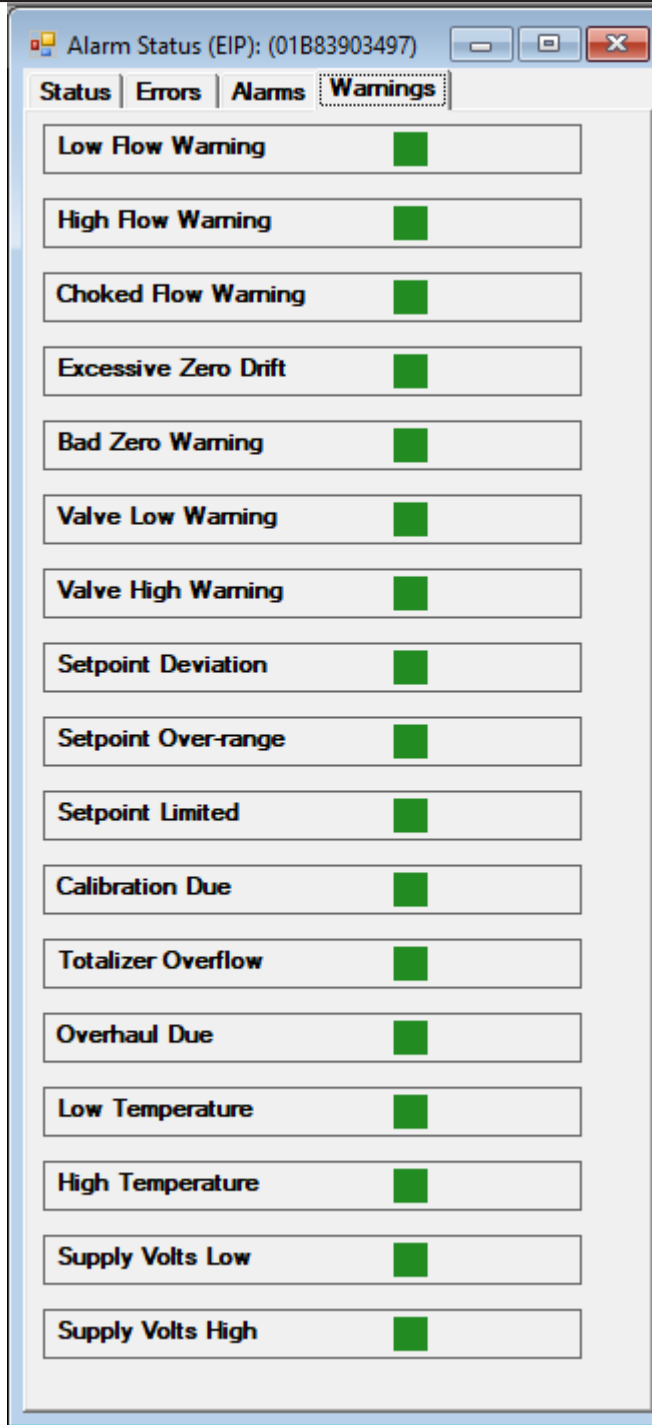

Figure 8-12 EthernetIP Alarm Status Window, Warnings Tab

DisplayCode	ErrorClass	Description	Alarm
1	Failure	NOSENSORFLASH	
2	Failure	FLASHPAGEINVALID	
5	Failure	SGPAGEINVALID_FAIL	
11	Failure	ADCMISSEDCYCLE	
12	Failure	ADC_OVERFLOW	
13	Failure	FLOWSENSOR_FAIL	
14	Failure	PRESSURESENSOR_FAIL	
15	Failure	TEMPERATURESENSOR_FAIL	
20	Failure	GASDB_ERROR	
21	Error	BADTABLE	
103	Error	FLASHDATALOST	
105	Error	SGPAGEINVALID_ERROR	
109	Error	DPINVALID	
110	Error	DPABORT	
113	Error	PAGECREATE_ERROR	
115	Error	FLOWALARMHIGH	
116	Error	FLOWALARMLOW	
125	Error	PRESALARMHIGH	
126	Error	PRESALARMLOW	
135	Error	TEMPALARMHIGH	
136	Error	TEMPALARMLOW	
140	Error	PRES_ZEROPROCESS_ERROR	
145	Error	CNTRLDEVALARM	
155	Error	ACTALARMHIGH	
156	Error	ACTALARMLOW	
0	Error	RAMPDATAERROR	
0	Error	RAMPABORT	
215	Warning	FLOWWARNHIGH	
216	Warning	FLOWWARNLOW	
225	Warning	PRESWARNHIGH	
226	Warning	PRESWARNLOW	
235	Warning	TEMPWARNHIGH	
236	Warning	TEMPWARNLOW	
245	Warning	CNTRLDEVWARN	
255	Warning	ACTWARNHIGH	
256	Warning	ACTWARNLOW	
270	Warning	TOTALOVERFLOW	
272	Warning	PGPAGEINDEXINVALID	
274	Warning	RANGETABLE_ERROR	
299	Warning	WARMUP	
0	Warning	EGMBADXFDSPLINE	

Exit Failures Errors Warnings ErrCodes

Figure 8-13 GP200 Alarm Status Window

8.3 User Totalizer Window

(The following section applies only to devices that support a totalizer and does not apply to SLA EthernetIP devices. For SLA EthernetIP devices, see [Section 7.4.1](#)).

The **User Totalizer** allows a user to track the total flow of a device over time from a user reference point in time. The User Totalizer is only supported if the device supports a hardware flow totalizer.

***NOTE:** The User Totalizer is different from the hardware totalizer. The hardware totalizer is a totalizer that exists in the device firmware. The hardware totalizer cannot be reset, as it is for maintenance purposes. The user totalizer, however, is based on the hardware totalizer.

The User Totalizer may be reset by clicking the Reset button in the window. The window's update rate and flow units displayed may be set by the user (see [Section 7.4](#)). The window shows the total elapsed time since the last reset.

User totalizer options are set via the User Totalizer options (see [Section 7.4](#)).



Figure 8-14 User Totalizer Window

8.4 Graph Window

The **Main Graph** window shows device measurements such as flow, flow set point, pressure, pressure set point, temperature, and valve position, over time. It also features some commonly used control functions.

Legend->

Main Graph->

Control Buttons->

Meters Panel->

Status Panel->

Graph Status Panel->

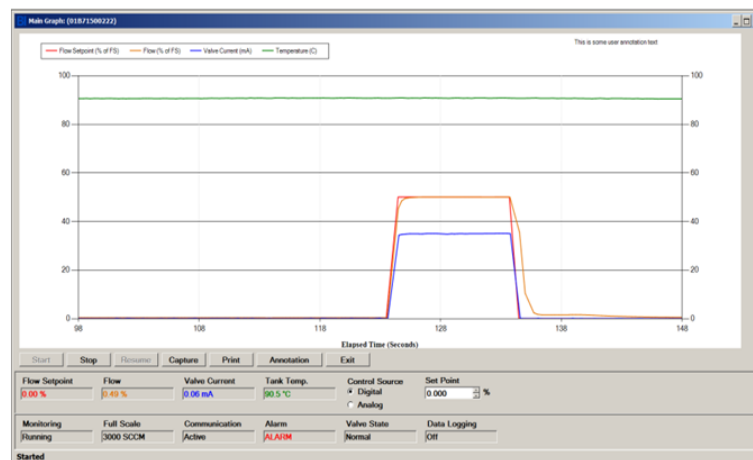

<-User Annotation

Figure 8-15 Main Graph Window (actual appearance may vary depending on device type)

When the main Graph window is opened it does not start monitoring automatically. To start monitoring, click the Start button. Click Stop to stop monitoring. Click Start to re-start, or Resume to resume monitoring.

There are a number of options of the graph that the user can select. They can be selected in the Tools->Options->Graph menu (see [Section 7.1](#)).

The parameters that are graphed on the window, the units used for the parameters, X scale, Y scale, and legend are all user options.

The left side Y axis is for flow, flow setpoint, pressure, and pressure setpoint. The right side Y axis is for valve position, valve current, temperature, and density.

The Meters Panel shows important device measurements. (The name “meters” was chosen because a flow meter measures flow, a temperature meter measures temperature, etc.). The exact parameters that are shown may change depending on the user graph settings and the type of device (see [Section 7.1](#)). The Meters Panel is also where the user selects the control source and set point.

The Control Source can be either Digital (BEST Software) or Analog (External) for control of the set point. If the control source is set to digital, the user controls the set point via BEST software via the diagnostics port (see Set Point Control section below). If analog is selected, the software no longer controls the set point, (but can still monitor the set points) – the set point is control by an external controller physically connected to the device on its normal control port (and not via the Diagnostics port). Selecting analog disables BEST software’s set point up/down control. Selecting digital control re- enables it. Changing the Control Source from analog to digital will cause the software to change the device’s set point to 0 for safety.

The Set Point Control allows the user to set the device’s set point via BEST software (if Control Source is set to digital). The units for the set point are displayed next to the numeric up/down control. These units are the same as set by the graph options for set point (flow or pressure set point depending on the type of device - see [Section 7.1](#)). If the user changes the units options under the graph options menu, the units here will be updated to match and the numeric value will be updated to the equivalent units.

The Basic Status Panel shows some basic status parameters. The displayed parameters are:

- Monitoring: Whether the main graph is currently Running or Stopped.
- Full-scale: Displays the full-scale flow or pressure range of the active device (value and units).

Communication: Will show “Active” or the last error message, if any.

Alarm: Will show “Alarm”, “Warning” or “Normal”. Alarm will show if any alarm is active. To see which alarm is occurring, open the Alarm Status window (see [Section 8.2](#)). If there is no alarm, but a warning is occurring, this will show “Warning”. To see which warning is occurring, open the Warning Status window (see [Section 8.1](#)).

Valve State: Will show the valve control state: Manual, Normal, Open, or Closed. Manual means manual control, normal means set point control of the valve. Open means valve override open. Closed means valve is forced closed.

Control Source: Analog or Digital.

Flow Totalizer: The value of the hardware totalizer (See also [Section 8.3](#)).

Data Logging: On Or Off.

Oper. Mode: The current operating mode of the device - Executing mode, or Idle/Safestate mode. (Show only on devise that support executing mode).

EIP Control: Shows “Yes” if the device is currently controller by the EthernetIP connection (shown only for SLA rev B EthernetIP devices)

There is a user Text Annotation block that can be used for labeling purposes. The text can be edited, moved, and resized. To edit the text block, click on the text block, type in the new text, then click off the block. To move the text block, click on the text block and a frame will appear - then drag the box to the desired location. To resize the text block, click on

the text block and a frame will appear – then drag one of the handles (sides or corners). To clear the text, select the text and edit it to an empty text string. If the text is hidden, click Find Annot. Double click the text box to edit the text.

Screen Capture: The graph can be saved to a graphics file by clicking Capture. Supported graphics file format are jpg, bmp, gif, png, and tiff.

Print Screen: The graph can also be printed. Click Print.

Cursor: The user can display a cursor on the graph. A cursor is cross-hair that can pin point a location on the graph. To activate a cursor, click anywhere on the graph with the mouse. A crosshair appears and in the lower right corner of the graph, a box appears with the X and Y location of the cursor Figure 8-16. To move the cursor, click on another location in the graph and the location of the cursor is updated in the box. To remove the cursor, right click on the graph. A context menu appears – click Clear Cursor (See Figure 8-17).

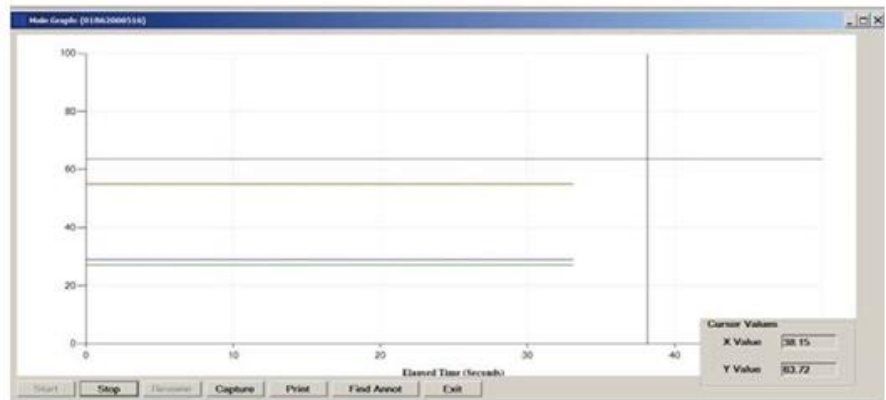

Figure 8-16 Main Graph Window with Cursor

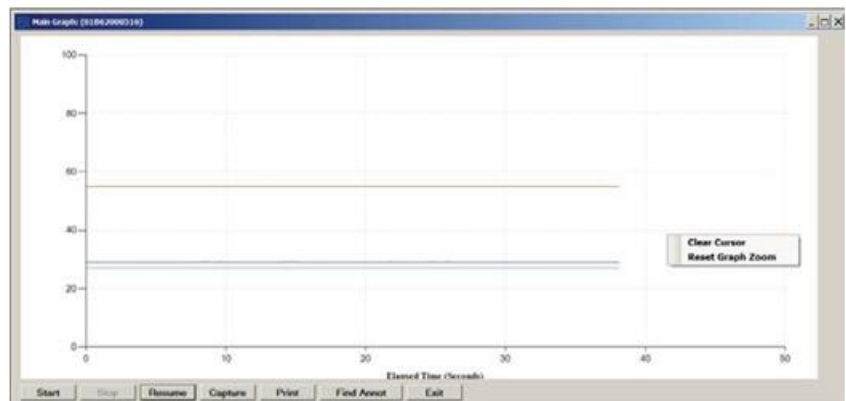

Figure 8-17 Main Graph Window with Context Menu

Zoom: The user can zoom in on a portion of the graph. To zoom in, click anywhere on the graph with the mouse, then drag diagonally to form a rectangle, then release the mouse. The graph shows a zoomed area of the graph and scroll bars appear (see Figure 8-18). To remove the zoom effect, right click on the graph. A context menu appears – click Reset Graph Zoom (see Figure 8-18).

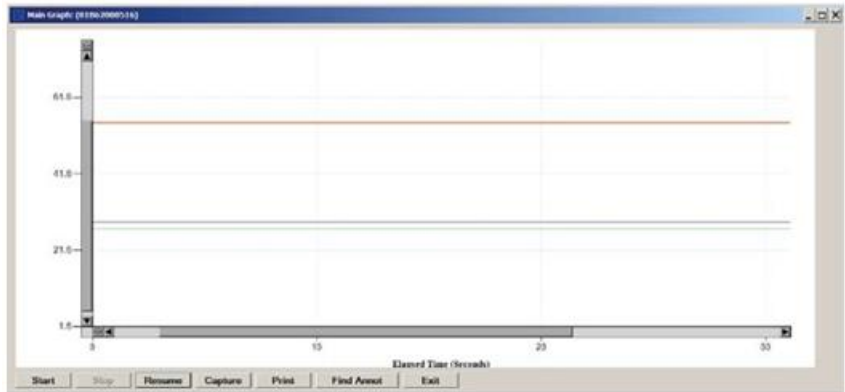

Figure 8-18 Graph Window Zoomed

NOTE: For some parameters, changing graph settings while the graph is running may require the graph to be closed and re-opened for the changes to take effect.

8.5 VDM Status Window

The VDM Status Window allows the user to view and change selected status parameters of a VDM device. When the window first opens, it is sampling data at a sample rate of a little slower than 1 sample per second. The user may stop, restart or execute a single sample. The user may also change the mux mode by selecting a mode from the New Mode drop-down and clicking Change.

If enabled for the current device, the user may also change the operating mode of the device by clicking one of the operating mode buttons.

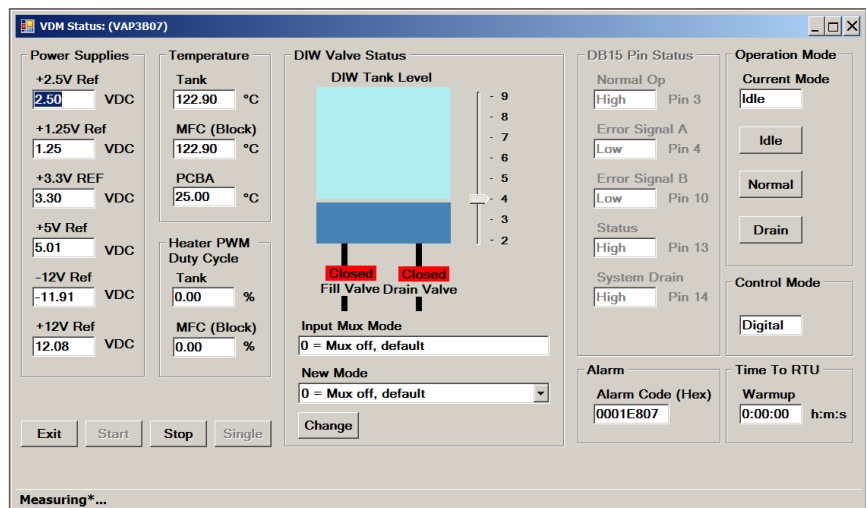

Figure 8-19 VDM Status Window

8.6 VDM Heater Diagnostics

The VDM Heater Diagnostics Menu allows the user to view and record the data of VDM device's heater and heater PWM data over time. The sample rate is 1 sample per second. The user may also print or capture the screen to graphics file. This menu item applies only to VDM300 devices.

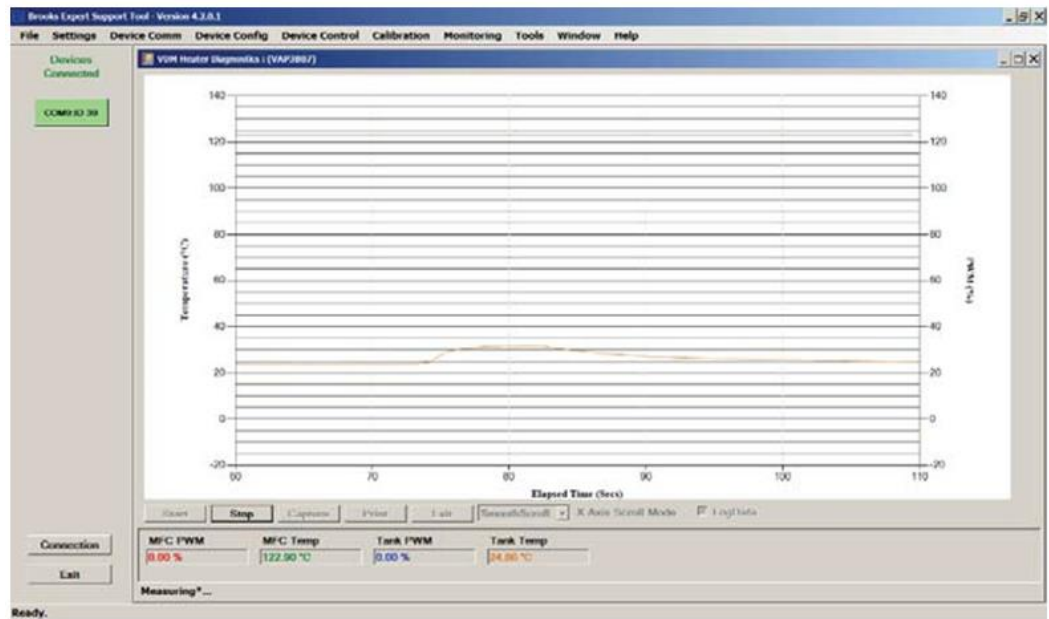

Figure 8-20 VDM Heater Window

8.7 Data Streaming

The **Data Streaming Menu** allows the user to record data from the device (any device that supports FloCom) over time, at a faster and more controlled rate than the main graph. The user can select which attributes to record, the sample rate, length of time to record, and file to save to. The file format is *.csv. Sample rate typically can be up to 500 Hz, up to eight attributes at a time, depending on selected options. The attributes available to select from depends on the type of device. Live data on the screen is not available during this operation. No changes or other communications with the device can occur via the diagnostics port while recording is ongoing.

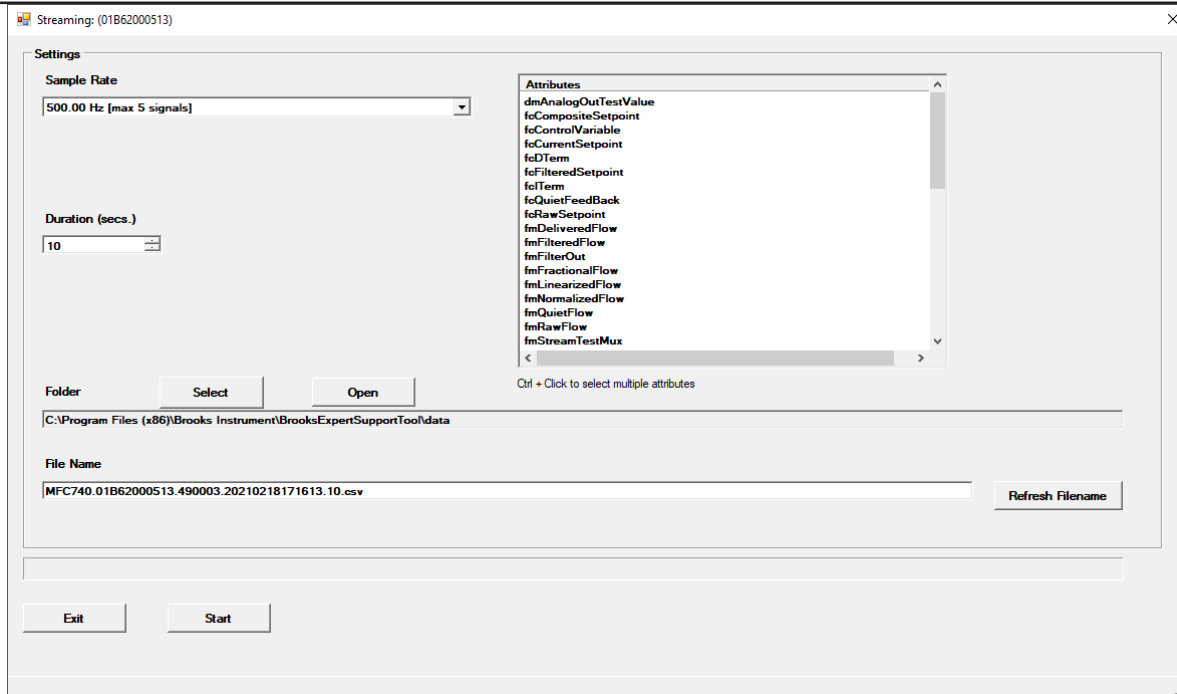

Figure 8-21 Streaming Window

8.8 VDM300 Dry-Down

The **VDM300 Dry-Down Menu** allows the user to perform an automated dry-down operation of the VDM300. The dry-down operation is typically performed with the device in the user's system, or a similar setup. A typical block diagram is shown in window of Figure 8-22.

The dry-down process consists of applying pressurized nitrogen to the device and cycling the exhaust valve on and off between pressurize and depressurize. The nitrogen is applied to the device's outlet port, applying the flow in reverse direction. The device heaters are turned on during this operation.

The dry-down process is a long-running automated operation (up to 8 hours) and, unlike the manual in-house process, the user would typically start the operation and run it unattended (without stopping for user prompts to switch manual external valves).

It is recommended that the user consult the factory for additional guidance for this operation.

The cycle times and other parameters may be adjusted to the user's preferences. Click the Settings button on the VDM300 Dry-Down Window (see Figure 8-22 and Figure 8-23).

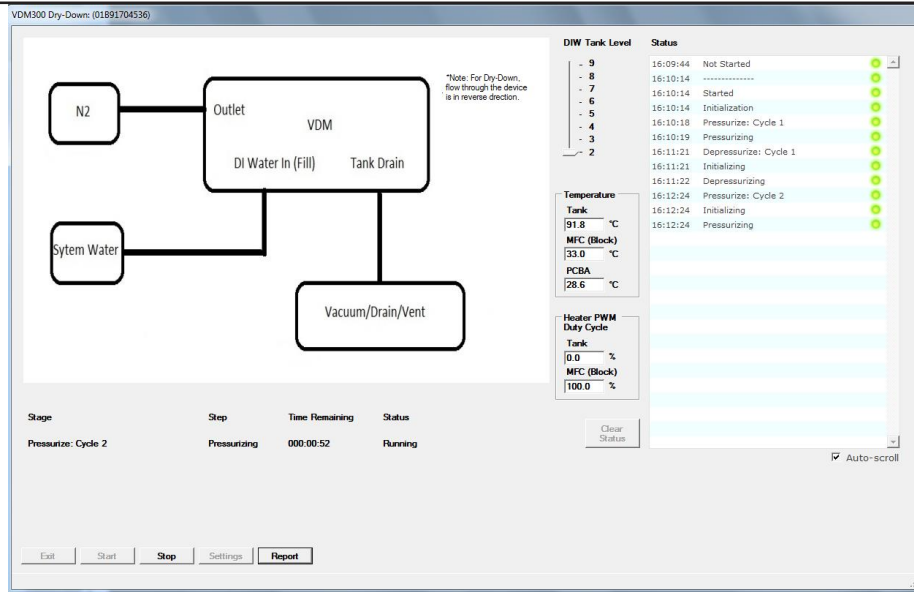

Figure 8-22 VDM300 Dry-Down Window

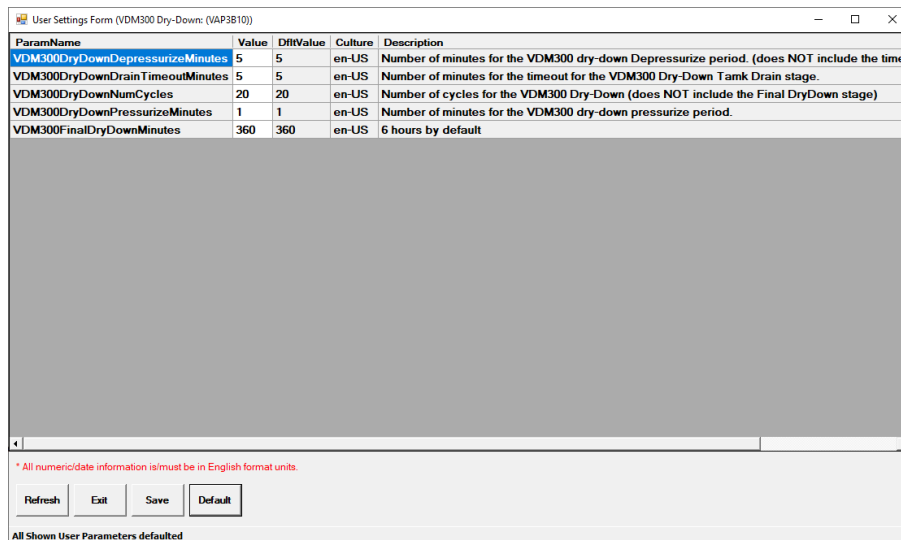

Figure 8-23 VDM300 Dry-Down Settings Window

To start the test, click Start on the VDM300 Dry-Down Window (see Figure 8-22). The software will prompt the user to set up some external valves. Then the automated test will start. If there is water in the tank, it will be drained. Then the cycling will take place unattended. At the end of cycling, the user will be prompted to close external valves as necessary.

The user may create a report of the data for documentation purposes. Click on Report on the VDM300 Dry-Down Window, or click on the menu Monitoring->VDM300 Dry-Down Reports from the BEST Main window. See [Section 8.9](#).

8.9 VDM300 Dry-Down Reports

The **VDM300 Dry-Down Reports Menu** allows the user to view, print, or save a report to log the results of a VDM300 Dry-Down operation. In order to be able to see this menu item, the software must be connected to a VDM300 device, or no device.

The screenshot shows a web browser window titled "vdm300.drydown.report.html". The main content area displays a "VDM300 Dry Down Report" for Device Serial Number 01B91704536, dated 10/07/2019, with a "Fail" result. A detailed table follows, listing the time, stage, step, status, result, and various parameters (Tank, Tank⁶, MFC⁵, PCB⁴) for each step of the dry-down process. The table shows two successful pressurization cycles followed by a failed depressurization cycle due to a user cancel. Control buttons for "Get Data", "Export to File" (with a PDF format dropdown), "Save", "Print", and "Exit" are visible on the right side of the window.

Time	Stage	Step	Status	Result	Tank	Tank ⁶	MFC ⁵	PCB ⁴
16:10:14	Initialization	Initializing	Running	Pass				
16:10:18	Initialization	Initializing	Initialization Completed	Pass				
16:10:18	Pressurize: Cycle 1	Initializing	Running	Pass				
16:11:21	Pressurize: Cycle 1	Pressurizing	Pressurize: Cycle 1 Completed	Pass	2	101.7	28.1	27.3
16:11:21	Depressurize: Cycle 1	Initializing	Running	Pass	2	101.7	28.1	27.3
16:12:24	Depressurize: Cycle 1	Depressurizing	Depressurize: Cycle 1 Completed	Pass	2	90.4	32.4	28.5
16:12:24	Pressurize: Cycle 2	Initializing	Running	Pass	2	90.4	32.4	28.5
16:13:26	Pressurize: Cycle 2	Pressurizing	Pressurize: Cycle 2 Completed	Pass	2	90.7	36.4	29.5
16:13:26	Depressurize: Cycle 2	Initializing	Running	Pass	2	90.7	36.4	29.5
16:13:31	Depressurize: Cycle 2	Depressurizing	User Canceled	Fail	2	91.2	36.9	29.6
16:13:31	Depressurize: Cycle 2	Depressurizing	Depressurize: Cycle 2 Failed	Fail	2	91.2	36.9	29.6
16:13:31	Closing Out	Closing	Running	Pass	2	91.2	36.9	29.6
16:13:36	Drain	Closing	Drain Failed	Fail	2	91.2	36.9	29.6

Data found and displayed.

Figure 8-24 VDM300 Dry-Down Report Window

Chapter 9 Tools Menu

The **Tools Menu Item** features some convenient utility tools (for reference only). Most of the features in this menu do not require a device connection.

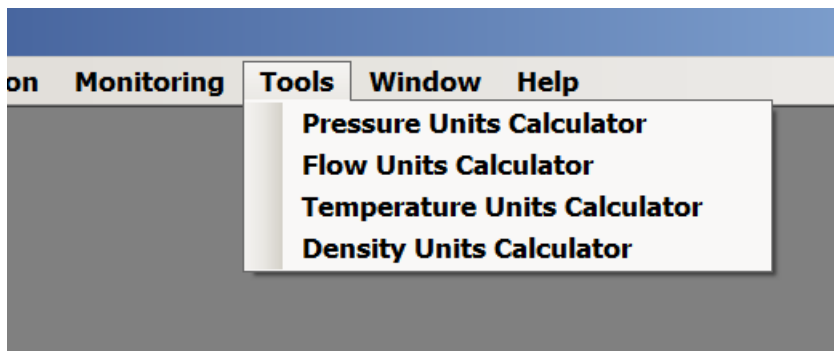

Figure 9-1 Tools Menu

9.1 Pressure Units Calculator

The **Pressure Units Calculator Menu Item** opens a convenient utility that can convert a pressure value from one unit to another.

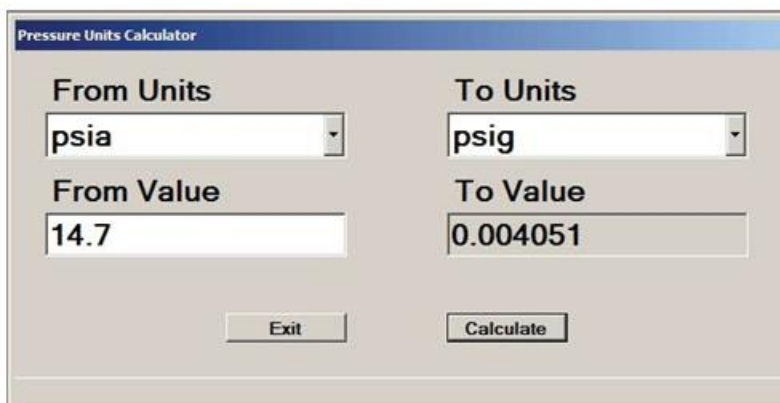
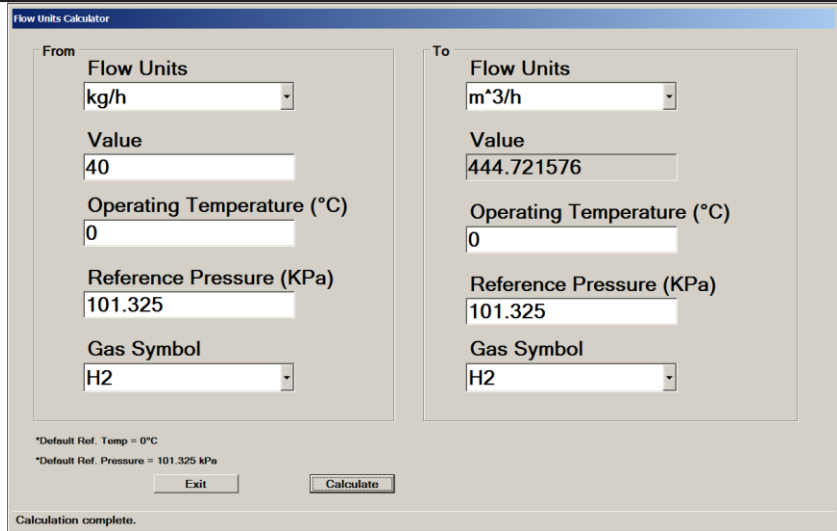

Figure 9-2 Pressure Units Calculator

9.2 Flow Units Calculator

The **Flow Units Calculator Menu Item** opens a convenient utility that can convert a flow value from one unit to another. The user can optionally factor into the conversion the reference temperature, and pressure.

Conversions involving mass-based units require a gas symbol in both drop-down controls.



The screenshot shows a software window titled "Flow Units Calculator". It is divided into two main sections: "From" and "To".

- From Section:**
 - Flow Units: kg/h
 - Value: 40
 - Operating Temperature (°C): 0
 - Reference Pressure (KPa): 101.325
 - Gas Symbol: H2
- To Section:**
 - Flow Units: m³/h
 - Value: 444.721576
 - Operating Temperature (°C): 0
 - Reference Pressure (KPa): 101.325
 - Gas Symbol: H2

At the bottom, there are two buttons: "Exit" and "Calculate". Below the buttons, it says "Calculation complete." and provides default values: "*Default Ref. Temp = 0°C" and "*Default Ref. Pressure = 101.325 kPa".

Figure 9-3 : Flow Units Calculator

9.3 Temperature Units Calculator

The **Temperature Units Calculator Menu Item** opens a convenient utility which can convert a temperature value from one unit to another.

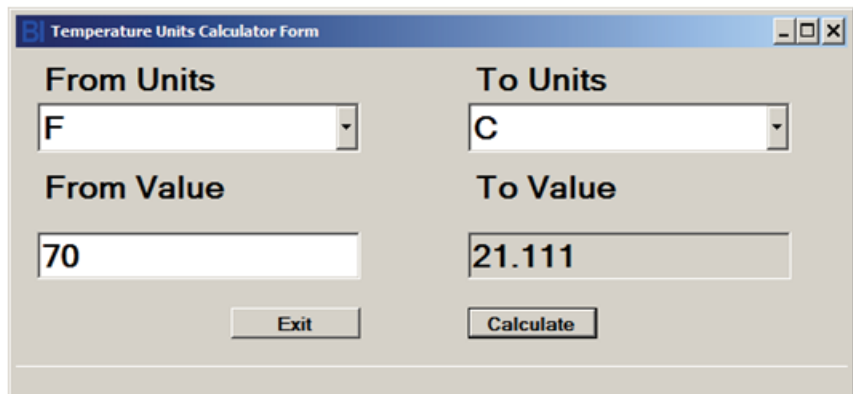

The screenshot shows a software window titled "Temperature Units Calculator Form". It is divided into two main sections: "From Units" and "To Units".

- From Units Section:**
 - From Units: F
 - From Value: 70
- To Units Section:**
 - To Units: C
 - To Value: 21.111

At the bottom, there are two buttons: "Exit" and "Calculate".

Figure 9-4 Temperature Units Calculator

9.4 Density Units Calculator

The **Density Units Calculator Menu Item** opens a convenient utility that can convert a density value from one unit to another.

Lookup Gas Density will calculate and show the density of the gas based on the reference temperature and pressure using the FloCom gas database.

The screenshot shows a software window titled "Density Units Calculator". It is divided into two main sections: "From" and "To".

- From Section:**
 - Density Units: kg/m^3
 - Value: 1
 - Operating Temperature ($^{\circ}\text{C}$): 0.00
 - Reference Pressure (KPa): 101.325
 - Gas Symbol: N_2
 - Buttons: "Lookup Gas Density" and "Calculate"
- To Section:**
 - Density Units: lb/in^3
 - Value: 0.000036

At the bottom of the window, there are two informational lines:

- *Default Ref. Temp = 0°C
- *Default Ref. Pressure = 101.325 kPa

An "Exit" button is located below these lines. A status bar at the very bottom of the window displays "Calculation complete."

Figure 9-5 Density Units Calculator

Chapter 10 Device Comm Menu

The **Device Comm Menu Item** is where BEST software performs communication tasks with a device. The **Connection** menu item establishes communication with a device. The **Terminal** menu item provides low-level communication (sending commands) with a device.

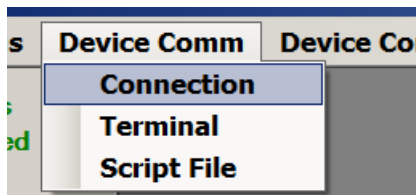

Figure 10-1 Device Comm Menu

10.1 Device Connection Window

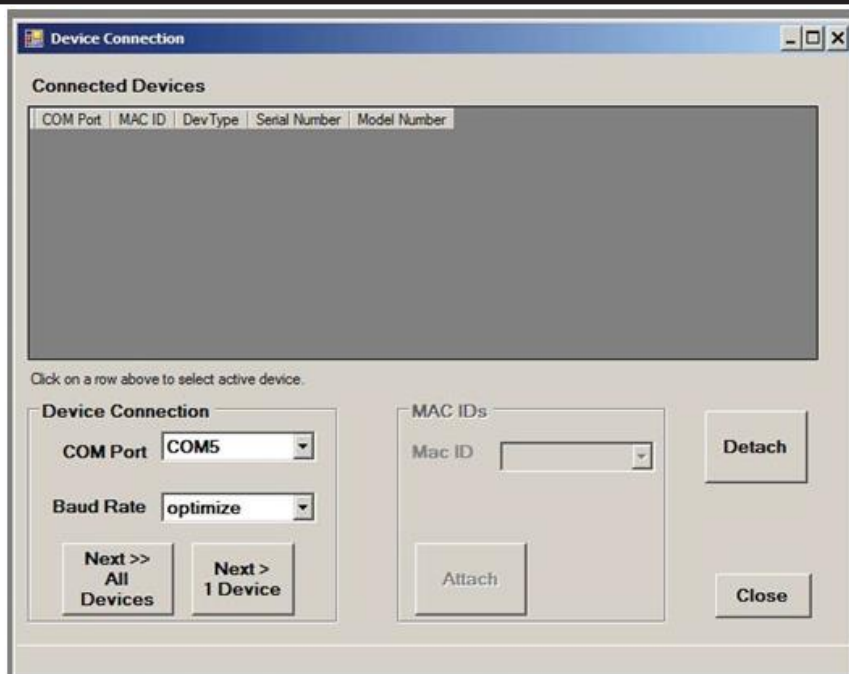

Figure 10-2 Device Connection Window, with no devices attached

Most features of BEST software require a connection to a device. If you attempt to access a feature that requires a device connection and you are not connected to a device, you will see a message box like the following:



Figure 10-3 No Device Connected

When BEST software starts, no devices are attached. Devices are attached via the device connection window. For convenience, the software opens the device connection window for you upon startup.

You can close the connection window if you wish. If it is closed, you may re-open the window via the Device Comm->Connection menu or the Connection button in the devices panel (see Figure 3-2).

BEST supports one or more devices connected simultaneously to their diagnostics ports. The use of the connection window is slightly different when using a single device compared to multiple devices.

First, in the Device Connection/Port drop-down list (see Figure 10-2), select the COM Port you are using to connect to each device as you connect to them one at a time.

Next, select the desired Baud rate from the Device Connection/Baud rate drop-down list. Most users will choose optimize, which will automatically select the fastest baud rate that successfully communicates with the device. If you have trouble attaching to a device, you can try a lower baud rate to troubleshoot. Your selected port and baud rate selections will be retained by BEST for your convenience.

Attaching a single device:

In case there is only a single device connected, Click the **Next > 1 Device** button to find the connected MAC address. After a few moments, if a device is located, its MAC ID (or “address”) is listed in the Mac ID drop-down list.

Once a device’s MAC address is located, make sure it is highlighted in the Mac ID drop-down list, then click on the Attach button. After a few moments, if it is attached, a row appears in the connected devices box, as shown in Figure 10-4.

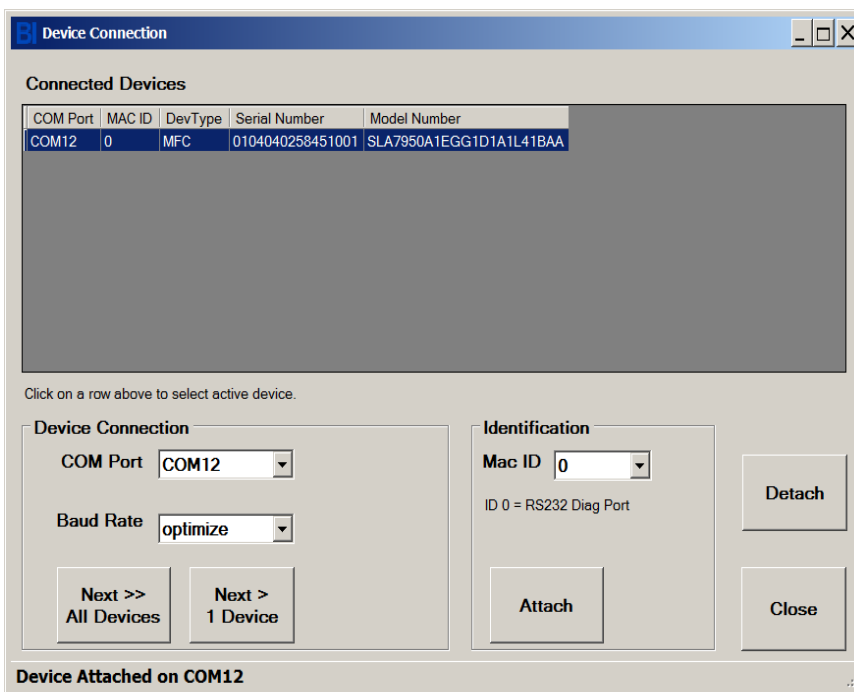

Figure 10-4 Connection Window, Single Device Attached

Attaching Multiple Devices Simultaneously:

BEST supports connecting to multiple devices simultaneously. There are two methods of doing this:

- 1.) Connecting multiple devices via a single COM port.
- 2.) Connecting multiple devices via multiple COM ports.

Single COM Port:

The diagnostics port of the device supports RS485 communication, which is a multi-drop communication type. This means that it's possible to connect multiple devices simultaneously to a single RS485 communication cable ("daisy chain"). This requires a custom splitter cable between a single COM port on the computer and multiple devices. (This type of cable is not supplied by Brooks Instrument). Each device on a single COM port must have a unique MAC ID address.

***NOTE:** You may not attach both FloCom and non-FloCom devices on the same COM port (FloCom devices are SLA Rev B, PC1xx, VDM300, GF40, and GF1xx devices. Non-FloCom devices are SLA Rev A, and Quantim devices. See also the equivalent BEST manual for Rev A and Quantim devices).

Multiple COM Ports:

You may also connect devices to multiple COM ports. Each device on a single COM port must have a unique MAC ID address on that COM port.

Using the Software to Attach:

If you have connected multiple devices to a COM Port, you use the **Next**

Click the **Next>>All Devices** button to find the MAC addresses of all devices connected on the selected COM port.

If the application has found one or more devices on the selected COM port, their MAC addresses will be listed in the **Mac ID** drop-down box. Choose the MAC address that you want to connect to from the drop-down box and click the **Attach** button for each device you wish to attach. (You must attach one at a time).

The attached devices will be shown in the Connected Devices as shown in Figure 10-5. They will also be shown as buttons in the devices panel (see Figure 3-2).

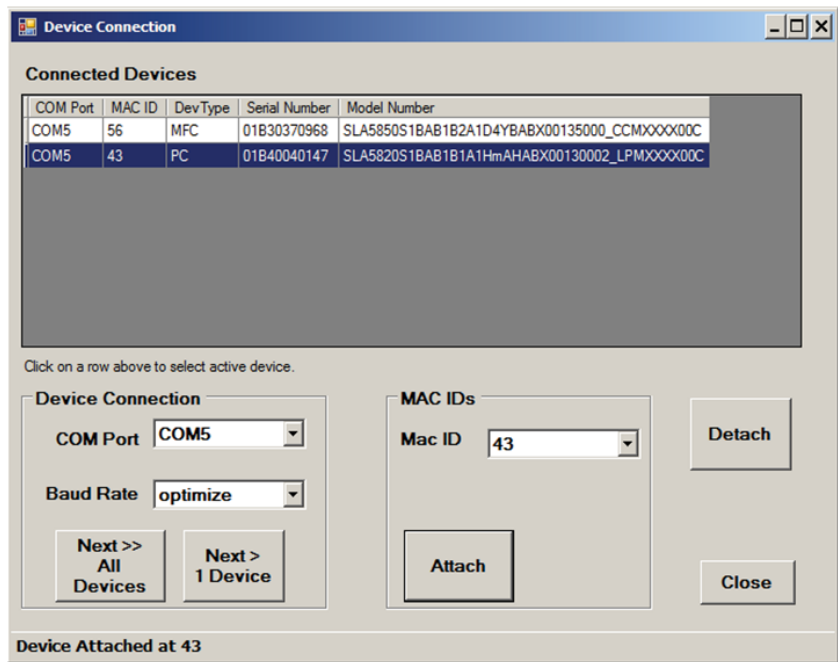

Figure 10-5 Device Connection Window, Multiple Devices Connected

Selecting the active device:

While multiple devices may be attached simultaneously, only one at a time is considered the active device. If a single device is connected, it is considered the active device. If multiple devices are attached, the active device is selected by clicking on its row in the Connected Devices box. In Figure 10-5, the device at address 43 is selected as the active device. An attached device may also be selected by clicking the button in the device panel or clicking the title bar of its associated main graph window. When a device is selected, the corresponding button is highlighted in green.

Device Type Codes:

In the Connected Devices box, under the Dev Type field, the possible values are:

- MFC Mass Flow Controller
- MFM Mass Flow Meter
- PC Pressure Controller
- RT Remote Transducer Device

For purposes of BEST, a VDM300 is considered of type MFC.

Detaching a Device: To detach a device, make sure that device is selected as the active device (by the blue highlight bar), then click the Detach button. The device will be removed from the Connected Devices list and from the devices panel. This will also close any windows open for that device.

***NOTE:** clicking the Detach button detaches the device highlighted in blue in the Connected Device list, NOT the device select in the Mac ID drop-down box.

***NOTE:** If you change physical connections to the device or computer while the software is running, you may need to exit the software and restart it for it to recognize the new connection.

You may close the Device Connection window with the Close button or clicking the “X” in the upper right of the Device Connection window’s title bar.

When you exit the BEST program, all devices are detached automatically.

10.1.1 Connecting to an Unconfigured Device

BEST can be used to attach to and set up devices (and “blank” boards) that have not yet been configured, or have an invalid/unsupported model code attribute. If you try to attach to such a device, and BEST does not recognize the device’s model code, it will display the Fix Model Code window (see Figure 10-6).

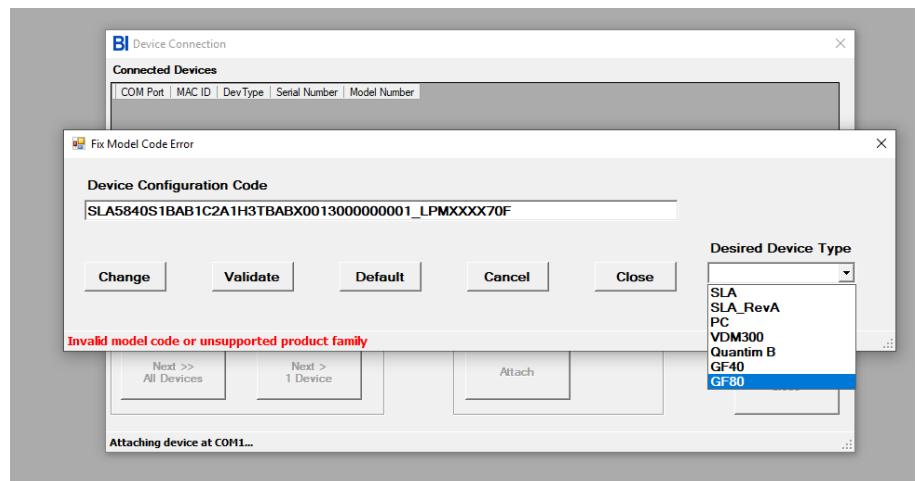

Figure 10-6 Fix Model Code Window

The Fix Model Code window gives the user an opportunity to fix or set up the model code. The user may fix the model code in one of two ways, as explained below.

The Device Configuration Code text box shows the current model code of the device. The user must select the Desired Device Type (“SLA” = SLA Rev B). Then they may use either method below.

1. Manually type in the model code, if the user knows the correctly formatted model code, then validate the code.

2. Set the model code to a default value, then use the model code window to set up the individual fields of the model code. This is the preferred method.

To use method 1:

1. Select the Desired Device Type.
2. Manually type in the model code.
3. Click Validate. If the validation is bad, check the model code, re-type, and try again.
4. Click Change.
5. The status bar will inform you if the change was successfully applied.
6. Close the Fix Model Code Window.

To use method 2:

1. Select the Desired Device Type.
2. Click Default. The default model code for the selected device type will be shown in the Device Configuration Code text box.
3. Click Change.
4. The status bar will inform you if the change was successfully applied.
5. Close the Fix Model Code window.
6. Open the Model Code window (under the Device Config->Model Code menu) (see **Section 11.5**) and set the fields to match your device's hardware.

After setting the model code correctly, the user should continue setting up other attributes as necessary.

10.2 Terminal Window

The **Terminal** provides low level communication access with a device. A connection to a device is required for this feature. This feature is for advanced users. For most device types, a software license is required to use this feature.

***NOTE:** All numeric or date information entered into this window must be in English culture format. Likewise, any numeric or data information displayed in this window are in English culture format.

The terminal window also features a Continuous button to continuously measure (once per second) a device attribute. This is convenient for troubleshooting.

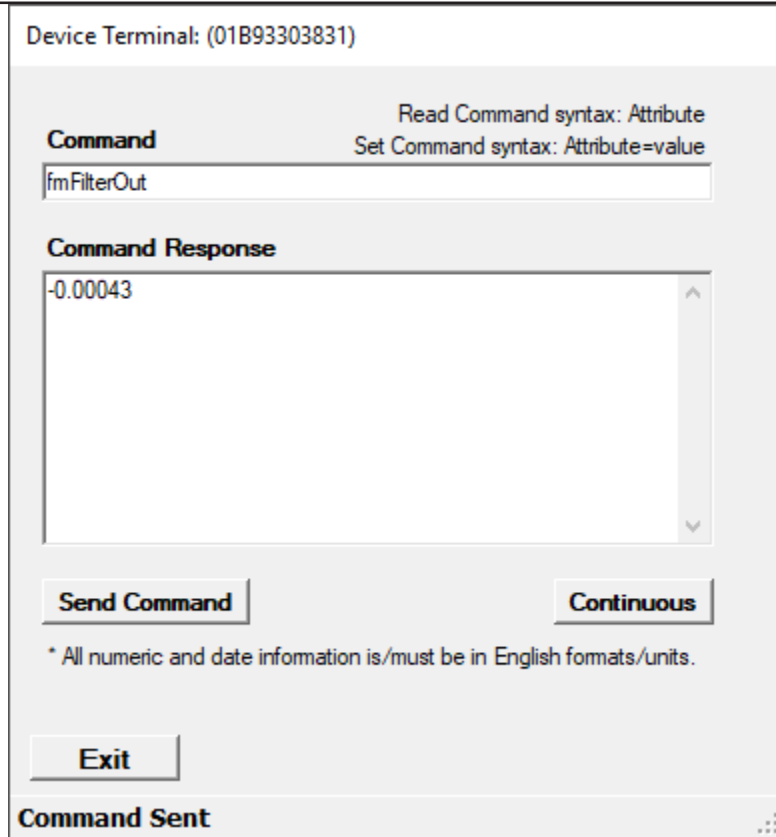

Figure 10-7 Terminal Window

10.3 Script File Window

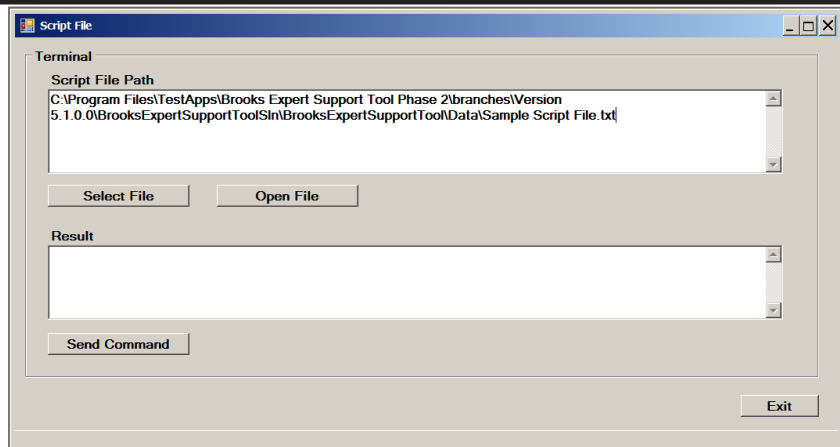

Figure 10-8 Script File Window

The Script File window allows the user to load and execute a file containing a batch of multiple commands. These commands are the same type of commands as executed one-at-a-time in the Terminal window. The user selects a file by clicking on “Select File”. The user may optionally open the file to view it by clicking “Open File”. To execute the file, click “Send Command”. The results are then shown in the Result text box.

A sample script file is shown below in Figure 10-9. Each line of the script file may be a command line, a comment line, or a blank line.

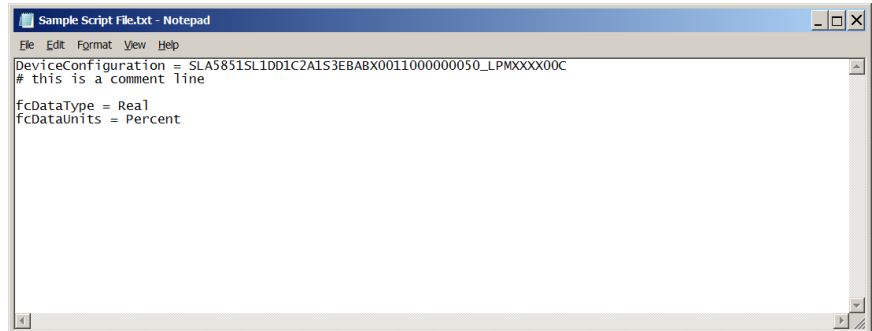

Figure 10-9 Sample Script File

Chapter 11 Device Config Menu

The **Device Config** Menu provides functionality to help a user configure a device with settings such as model code, control mode, alarm settings, and protocol settings. Access to individual settings is device- and license-specific. Functions that are not supported for a particular device will not be visible.

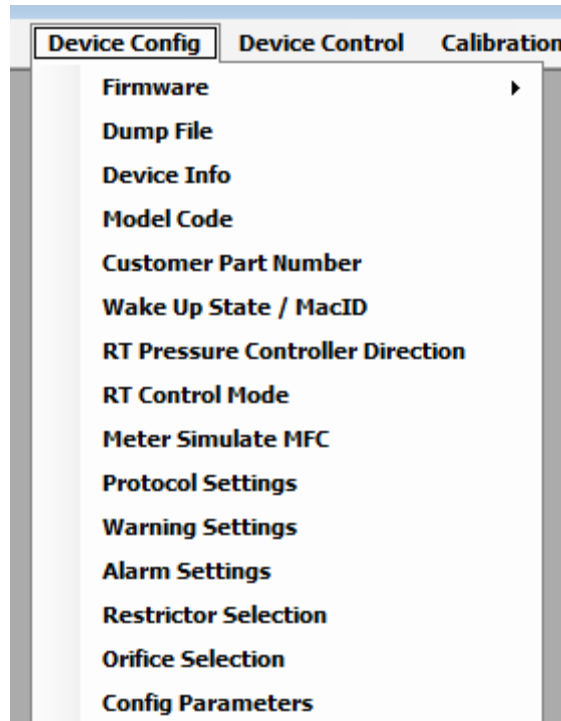

Figure 11-1 Device Config Menu
(not all device types support all menus).
(Config Parameters menu is for SLA Rev A and Quantim B devices:
see the separate user manual for details).

A device connection is required to use most of the config functions.

Also, for most menu functions, if device control source is set to external (analog) control, the software will first ask if the user wants to set control to digital/ BEST control (required for most config functions).

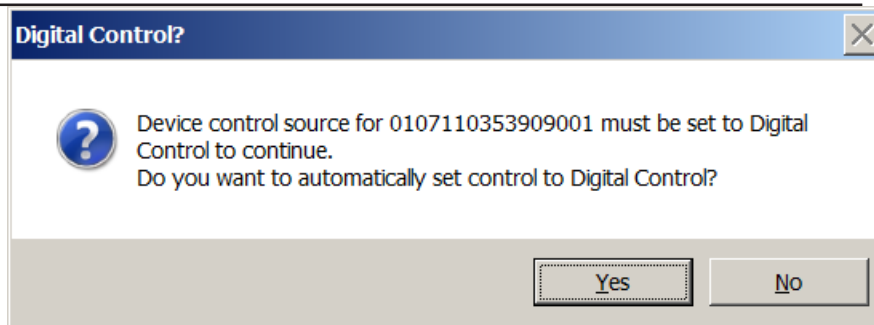

Figure 11-2 BEST Control Message

11.1 Firmware

The Firmware menu allows a user to load firmware or a gas database into a device where supported.

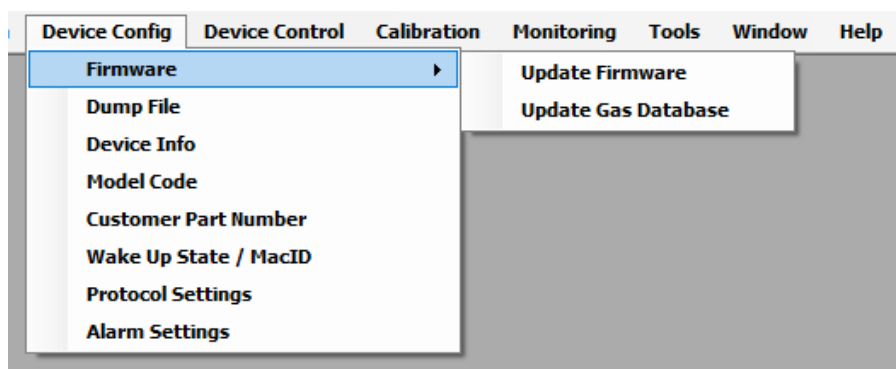

Figure 11-3 Firmware Menu

11.1.1 Update Firmware

The Update Firmware menu allows a user to load firmware into a device. It also allows a user to view the current revision of the firmware in the device.

The user must obtain the desired firmware file (contact Brooks Instrument). Then select the file under the Firmware Update File Path text box. Then select Update. After a confirmation pop-up, the software will load the firmware into the device.

***NOTE:** Only one device must be attached on a given COM Port for the firmware update.

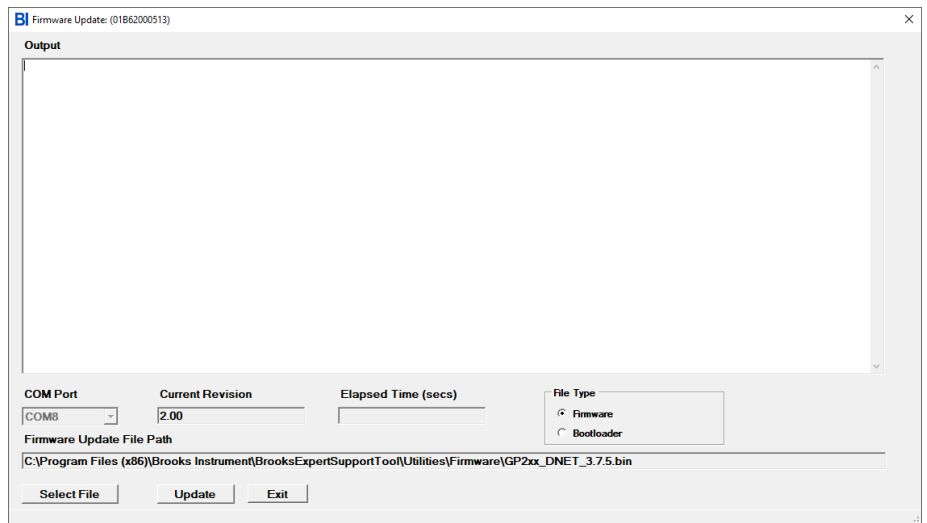

Figure 11-4 Firmware Update Window

11.1.2 Update Gas Database

The Update Firmware menu allows a user to load a gas database into a device. It also allows a user to view the current revision of the gas database in the device.

Currently, only the GP220 device is supported for this operation.

The user must obtain the desired gas database file (contact Brooks Instrument). Then select the file under the Gas Database Update File Path text box. Then select Update. After a confirmation pop-up, the software will load the gas database into the device.

***NOTE:** Only one device must be attached on a given COM Port for the firmware update.



Figure 11-5 Gas Database Window

11.2 Dump Files

BEST software allows the user to save and reload a (virtually) complete set of device settings in a file. Access to this feature may be dependent upon device type and software license level. This type of file is called a dump file.

NOTE: It is strongly recommended that when you first receive a new device, to immediately save the settings in a dumpfile as a backup for future reference or restoration.

Dump files are saved in an unencrypted format.

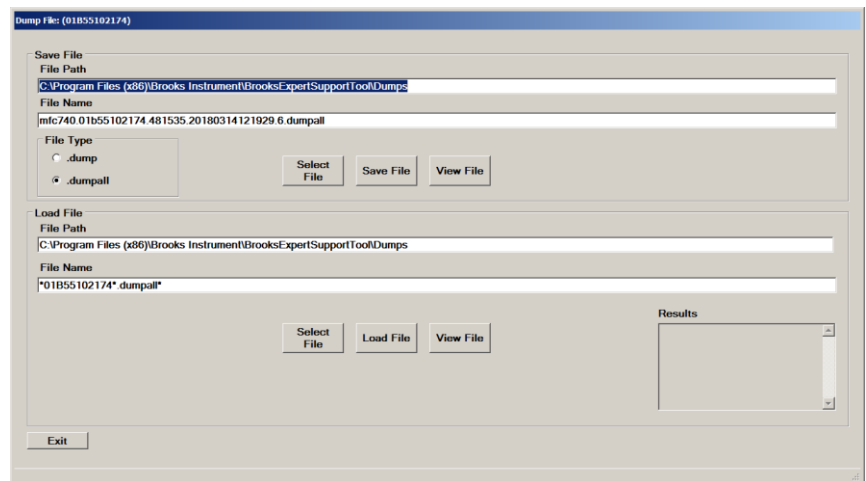

Figure 11-6 Dump File Window

There two formats of dump file: dump and dumpall. Dumpall is a comprehensive set of attributes including “live” attributes. A dump file contains only the settable (non-live) attributes. BEST can save or reload either type – just select the desired file extension type.

File names are by default coded using the device serial number and the date/time.

When the Dump File window opens, it shows a date-coded dump file name for the current device serial number and selected dumpfile type. To select a different file name, edit the file name/path, or select a new file by clicking Select File.

To save a dump file, first select a file type under the Save File block, then click Save File. If a file already exists, saving a file again will not overwrite any existing file. It may take a few minutes to complete the save operation.

An existing dumpfile may be used to reload settings into a device. The file path of the last used dumpfile path is displayed in the File Path text box on the form. To change the file, click Select File or type in the file path directly.

***NOTE:** Take caution to load only a dumpfile specified for the current device (same serial number). Prior to loading a dumpfile, the software will check the serial number of the device and compare it to the serial number in the dumpfile. If they don't match, a warning will be displayed. It is recommended that you do NOT ignore this warning.

To reload a dumpfile, first select a file by clicking the Select File button. Then click Load File. A series of warnings will be displayed. A reload may take a minute or two. After reloading, the device will be automatically rebooted. Then, the results text box will show any attributes from the dump file that were not able to be loaded. It is not unusual for a few attributes from the file to fail to load.

11.3 Device Info

The **Device Info** menu item allows a user to view selected information about a connected device. This window is read-only, except for the device serial number (useful for advanced users when rebuilding to new device). The device serial number and sensor serial number are writable only if the user has the Pro license and the device supports it.

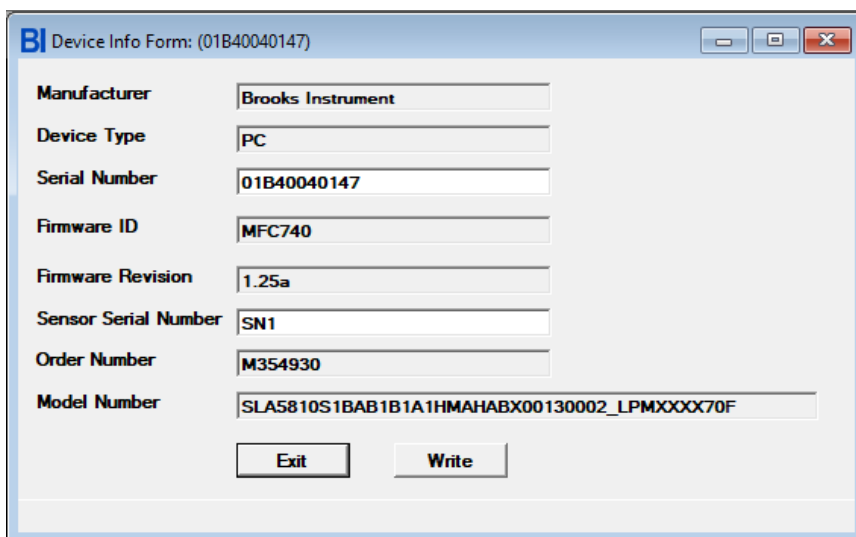

Figure 11-7 Device Info Window
(the data shown may vary depending on device type)

11.4 Gas Page Configuration

The Gas Page Configuration menu item allows the user to do a configuration of the settings for a device for a single gas “page”. This menu item merely opens the Calibration window with the Customer Page tab pre-selected. See Section 13.12 for more details.

11.5 Model Code Window

The model code window allows the user to view and edit the device’s model code. The model code (also called the Product Data Code or “PDC”) is stored in a device and identifies the type and options of a device. The model code is a formatted string of text characters with coded fields representing various device options.

Viewing the model code can provide key information for the user about a device. The model code window can assist the user in decoding and editing the fields.

Most users will not need to modify the model code, as the model code is typically configured by the factory. However, advanced users, such as those who obtain unconfigured devices, may need to modify the model code. A license is required to modify the model code. BEST does not support model code editing for all devices, even with a license.

When editing the model code, to protect the integrity of the model code text, the model code window does not allow the user to directly edit the text of the model code. The model code window requires the user to make selections from pre-defined choices for each field.

***NOTE:** It is very important to have a correct model code in the device (the model code that matches the hardware configuration), especially before beginning a device calibration. The model code is complex, so exercise caution when modifying it.

Figure 11-8 Model Code Window

The process for modifying the model code is as follows.

First, select a parameter to change (you may modify only one parameter/ field at a time). See **Figure 11-8**. This is chosen from the Parameter drop- down box. Notice that as you change the selected parameter there, a section of the model code above in the Full Code text box is highlighted – this is the corresponding field of the full model code. Notice also that the current value text box changes, as well as the description.

Next, select a new value or new value numeric from the New Value drop-down box. Notice that as you change the value, you may see a new description of the new value.

When you have selected the new value that you want, click Update. Note that the model code field will not be updated in the device unless you click Update. Notice that the field value in the Full Code text box is also updated to the new value.

***NOTE:** All numeric or date information entered into this form must be in English culture units/formats. Likewise, any numeric or data information displayed in the form are in English culture units/formats.

Special Fields:

Restrictor Type: For flow devices, the Restrictor Type field is used for restrictor type code, but for pressure controllers, this field is used for pressure transducer range code.

Gas Code: The gas code field is for the process gas, not the calibration gas (if the calibration gas is different than the process gas - see [Section 13.12](#)). This code must be an integer number.

Gas Range: The gas range field is the range for the process gas, not the calibration gas (if the calibration gas is different than the process gas - see [Section 13.12](#)).

Gas Units: The gas units field is the units for the process gas, not the calibration gas (if the calibration gas is different than the process gas - see [Section 13.12](#)).

Output Enhancements: For Biotech devices (field = S, T, U, or V), this field cannot be modified.

It is also recommended that after changing the model code, to detach the device, cycle power and then re-attach, or reboot the unit (see [Section 12.1](#)).

11.6 Customer Part Number Window

The Customer Part Number window allows the user to read and set the customer part number attribute in the device, if it supports it.

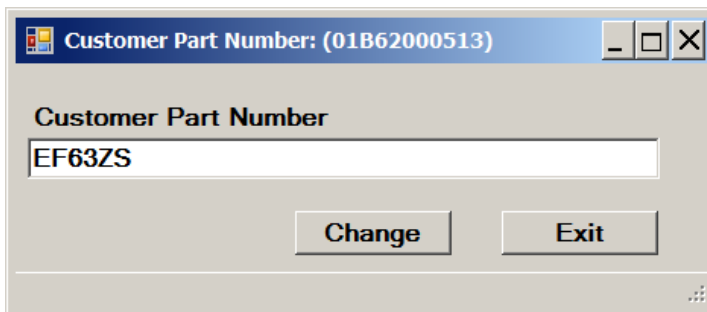

Figure 11-9 Customer Part Number Window

11.7 Wake Up State

The Wake Up State window allows the user to configure the state of the device the next time it powers up or reboots (“wakes up”), if the device supports it. In this window, the user may also set the control source, the diagnostic port Mac ID (address), or RT Device Control mode (for RT devices) upon reboot. See [Figure 11-10](#).

When the window opens, it shows the current wake-up state. The user may change any of these parameters. The user must click Change to apply these changes. The control source is for the power-up control state, not the current control state (see [Section 8.4](#) to change the current control state).

For the Diagnostic Port Mac ID, after the user clicks Change, the device will be rebooted (after the user confirms), and the device will remain attached, but with the new Mac ID number.

***NOTE:** the wake-up state control source (Digital or Analog) is not necessarily the current control state – it is the state of the device after a power-up or reboot.

The RT Device Control Mode block only appears for RT devices. This is the same function as the RT Control mode menu (see [Section 11.9](#)).

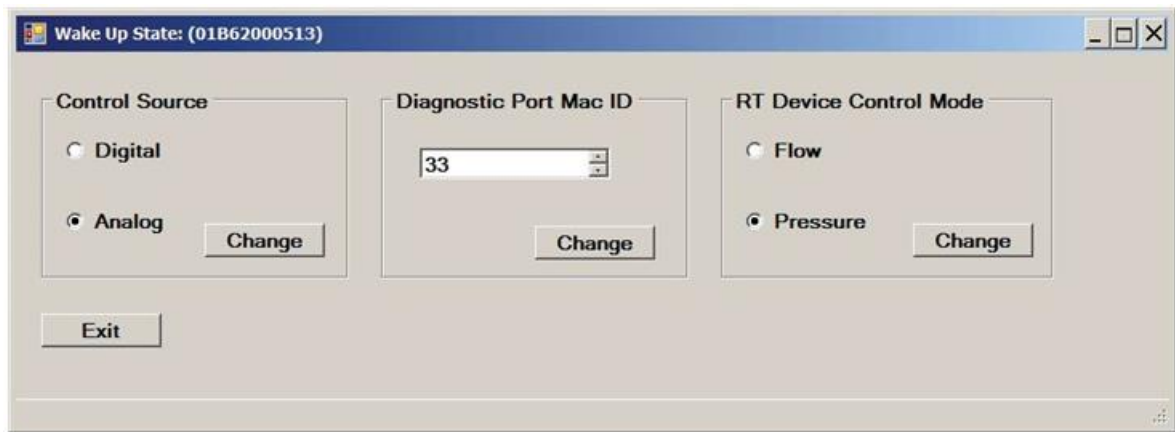

Figure 11-10 Wake Up State Window
(the RT Device Control Mode block appears only for RT devices)

11.8 RT Pressure Controller Direction

The RT Pressure Controller direction window is used to change the direction (upstream or downstream) of the pressure mode of an RT device.

This change is available only for RT devices (not available for pressure controller devices).

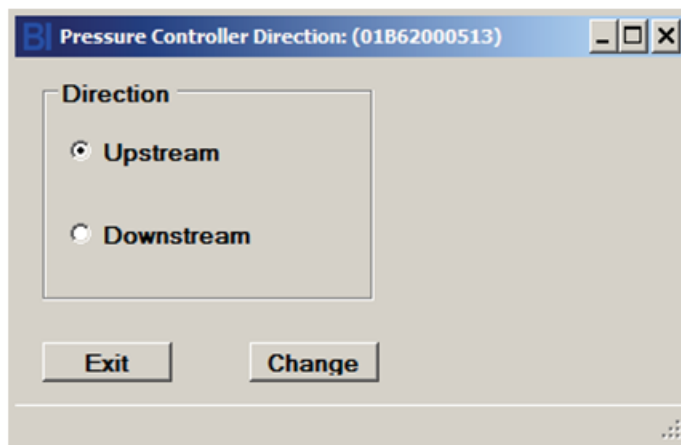

Figure 11-11 Pressure Controller Direction Window

11.9 RT Control Mode

The RT Control Mode window is used to change the current control mode of an RT device between Flow control and Pressure control modes. This window is only available for RT devices.

***NOTE:** This change only affects the current state of the device, not the Wake-Up state (see [Section 11.7](#) for the Wake-Up State).

The window ([Figure 11-12](#)) also shows a live reading of the remote pressure transducer voltage, if the user clicks Start.

***NOTE:** the changes won't be applied unless the user clicks Change.

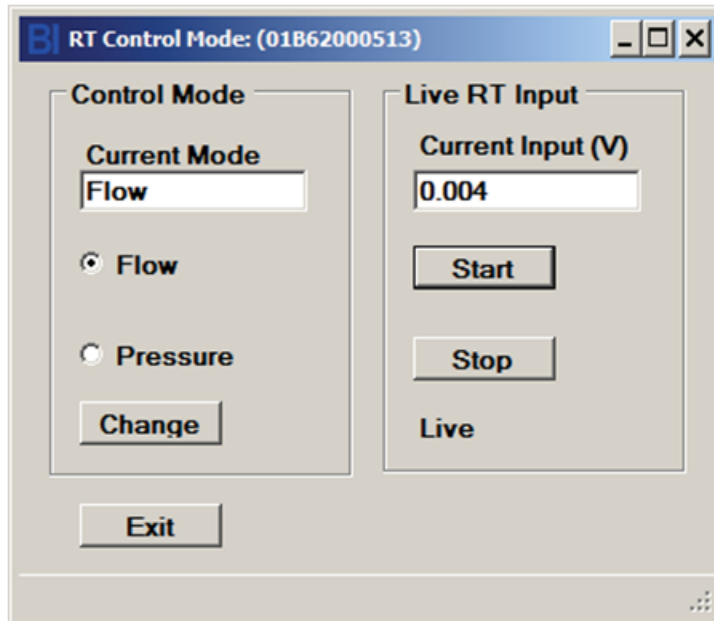

Figure 11-12 RT Control Mode Window

Changing the Control mode will require a device reboot for the change to take effect. The software will prompt and guide the user to do a reboot.

11.10 Meter Simulate MFC (Meter Calibration)

The **Meter Simulate MFC** window is used to allow a meter device to simulate an MFC device. This mode is needed for specific calibration situations, such as when calibrating a meter device using a temporary external valve directly connected to a meter device's electronics.

A license is required for the use of this feature. This feature is supported only for SLA, SLA Rev A, GF40, and GF1xx devices.

There are two ways of calibrating an SLA meter device using BEST:

1. **Using the valve output of the meter.** Since the meter version of Brooks SLA products contains the same electronics circuitry as the controller version, it's possible to connect a standalone valve or a compatible valve from a Brooks SLA controller to the valve output of the electronics circuitry. If the Meter Simulate MFC window is used, the meter device will act as a controller and can be calibrated just like with any MFC controller. After calibration, the device type needs to be configured back to MFM. Note that this valve connected to the meter needs to be in the flow path during calibration (see also [section 13.12](#) for full calibration instructions)
2. **Using an external valve.** In case it's not possible to connect a standalone valve or a compatible valve from a Brooks SLA controller to the valve output of the electronics circuitry, it's possible to put an external valve in the flow path and regulate flow using this external valve. Note that the device type needs to be configured to MFM. During the calibration, the user will be prompted to manually adjust the flow indicated in the pop-up window (see [Figure 13-29](#)), to a certain percentage by using the external valve (see also [Section 13.12](#) for full calibration instructions).

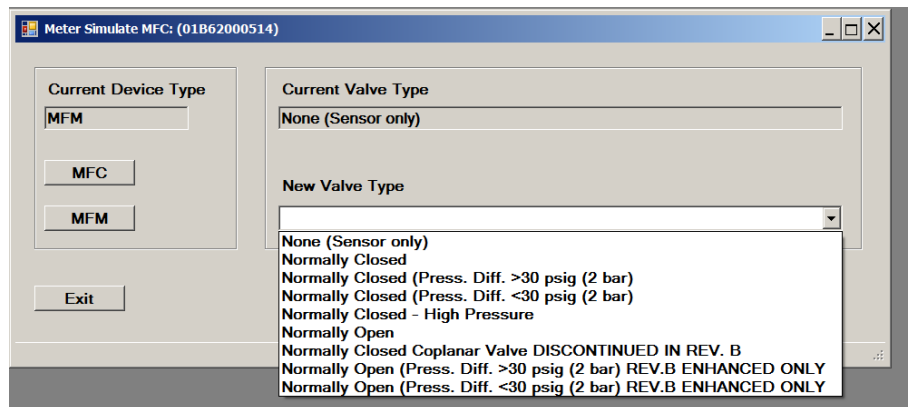

Figure 11-13 Meter Simulate MFC Window

To use this feature on meter device:

1. Click the menu item Device Config->Meter Simulate MFC.
2. Select the desired valve type under New Valve Type.
3. Click MFC.
4. Perform calibration as with an MFC device.
5. Click the menu item Device Config->Meter Simulate MFC.
6. Select None (Sensor Only) under New Valve Type.
7. Click MFM.

***NOTE:** Changing the device type with this feature will also change the model code and other attributes accordingly, so remember to change this back to MFM device type when finished.

11.11 Protocol Settings Window

The **Protocol Settings** window allows a user to change protocol settings for the device's main control port. Reference the device's specific supplemental manual for detailed information concerning the device's communication protocol.

***NOTE:** these settings are not for the diagnostics port communication settings.

***NOTE:** The user must click Apply for settings changes to take effect.

The exact protocol settings window that appears depends on the type of protocol installed on the device. The software automatically detects the protocol type of the device. The exact parameters shown depend on the type of device.

The types of protocol windows are:

- S-Protocol (RS485)
- DeviceNet
- EtherCAT.
- Field Bus
- EthernetIP

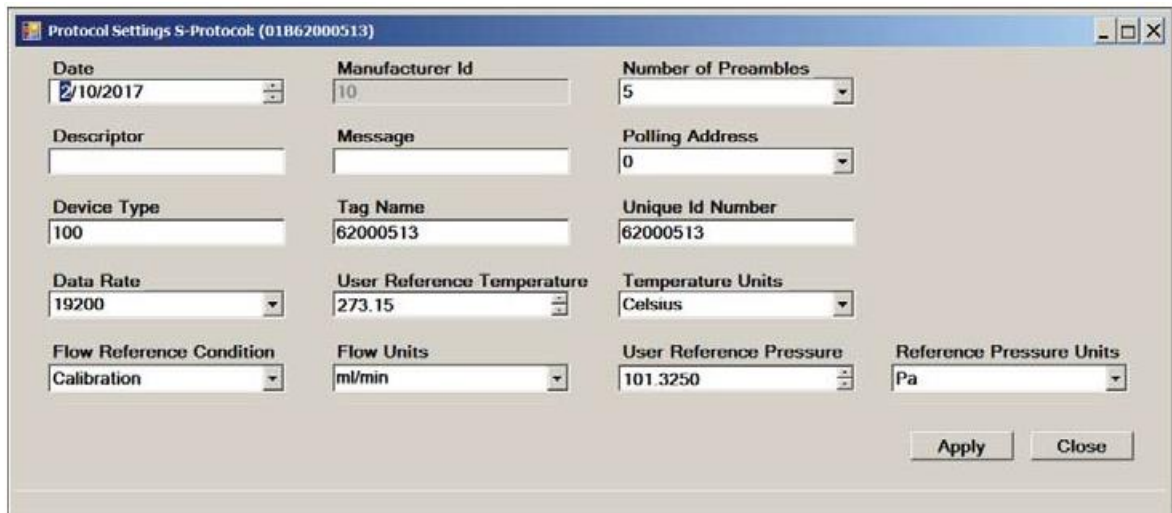

The screenshot shows a window titled "Protocol Settings S-Protocol: (01B62000513)". The window contains several configuration fields arranged in a grid:

Date: 2/10/2017	Manufacturer Id: 10	Number of Preambles: 5	
Descriptor: (empty)	Message: (empty)	Polling Address: 0	
Device Type: 100	Tag Name: 62000513	Unique Id Number: 62000513	
Data Rate: 19200	User Reference Temperature: 273.15	Temperature Units: Celsius	
Flow Reference Condition: Calibration	Flow Units: ml/min	User Reference Pressure: 101.3250	Reference Pressure Units: Pa

At the bottom right of the window are two buttons: "Apply" and "Close".

Figure 11-14 Protocol Setting (S-Protocol) Window

Table 11-1 S-Protocol Configuration Parameters

Parameter	Description
Date	32-bit integer value that represents the date value that is written and read via the S-Protocol Communication port. The Date value can be utilized by the user for any purpose and has no effect on the device
Descriptor	A 16-character string that the user can use to describe the device. This parameter can be written and read via the S-Protocol Communication port.
Device Type	Read Only. Will always be 100 for SLA Enhanced devices.
Data Rate	Sets the data rate for serial communications of the S-Protocol port. Must be 9600, 19200, or 38400.
User Ref. Temp.	Reference Temperature (K) for which flow is to be reported if the user-specified Standard Reference Conditions.
Manuf. ID	Read Only. Always 10 for Brooks Instrument devices.
Message	A 32-character string that the user can use for any desired purpose. This parameter can be written and read via the S-Protocol Communication port.
Tag Name	8-character string used to identify the device on the network to obtain the device's long address.
Unique ID No.	A 32-bit integer in the range of 0 to 16777216. This value is assigned by Brooks and must be unique for all devices supporting the RS485 S-Protocol.
User Ref. Pressure	Reference Pressure (Pa) for which flow is to be reported if the user-specified Standard Reference Conditions are selected.
Number of Preambles	The number of Preamble characters that the device will transmit as part of every response message on the S-Protocol communications port.
Polling Address	Short address of the device, must be in the range 0 to 15. This address can be used to access the long address from the device.
Flow Units	Defines the UOM that flow is to be reported in on the S-Protocol Communications Port.
Temp. Units	Defines the UOM that temperature is to be reported in on the S-Protocol Communications Port.

***NOTE:** Brooks Instrument provides an S-Protocol manual that describes the operation of the S-Protocol supporting devices. Contact the Factory or your local sales representative for more information.

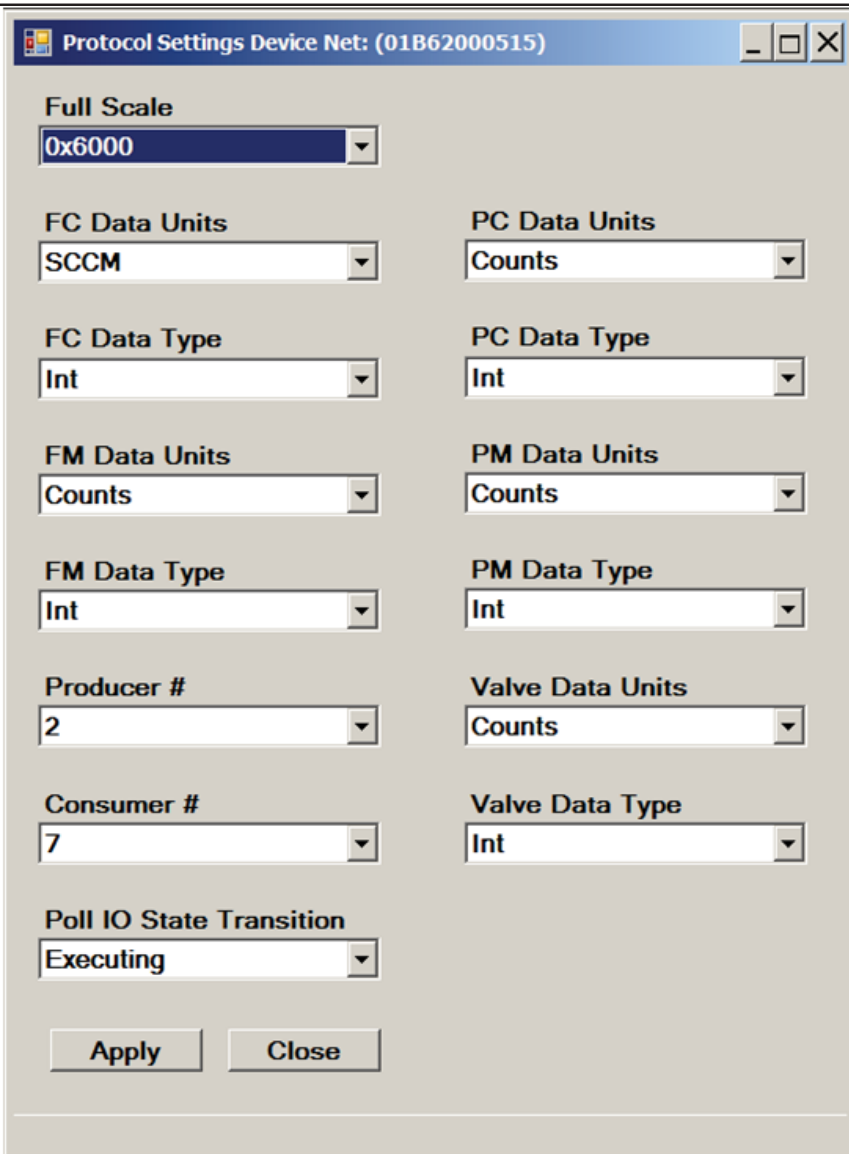

Figure 11-15 Protocol Settings (DeviceNet) Window

Table 11-2 DeviceNet Configuration Parameters

Parameter	Description
Full-scale	Represents the value in counts reflecting the full-scale of 100%.
Producer#	Sets the assembly instance used for sending data from the device to the master during Poll IO communication.
Consumer#	Sets the assembly instance used for sending data from the master to the device during Poll.
Poll IO State Transition	Defines the state of the device, Idle or Executing, when a Poll I/O connection is established.

***NOTE:** Brooks Instrument provides a DeviceNet manual that describes the operation of the DeviceNet supporting devices. Contact the Factory or your local sales representative for more information.

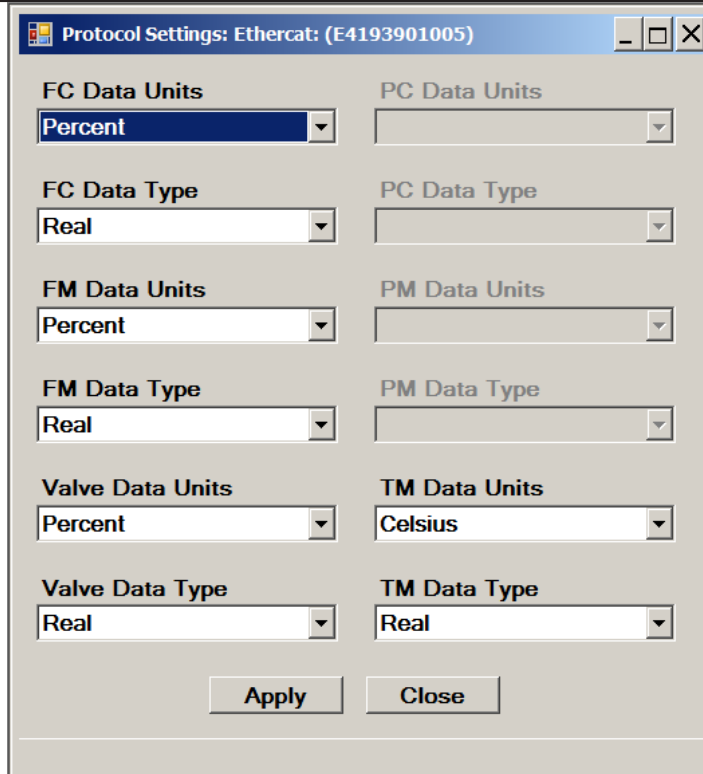

Figure 11-16 Protocol Settings (EtherCAT) Window

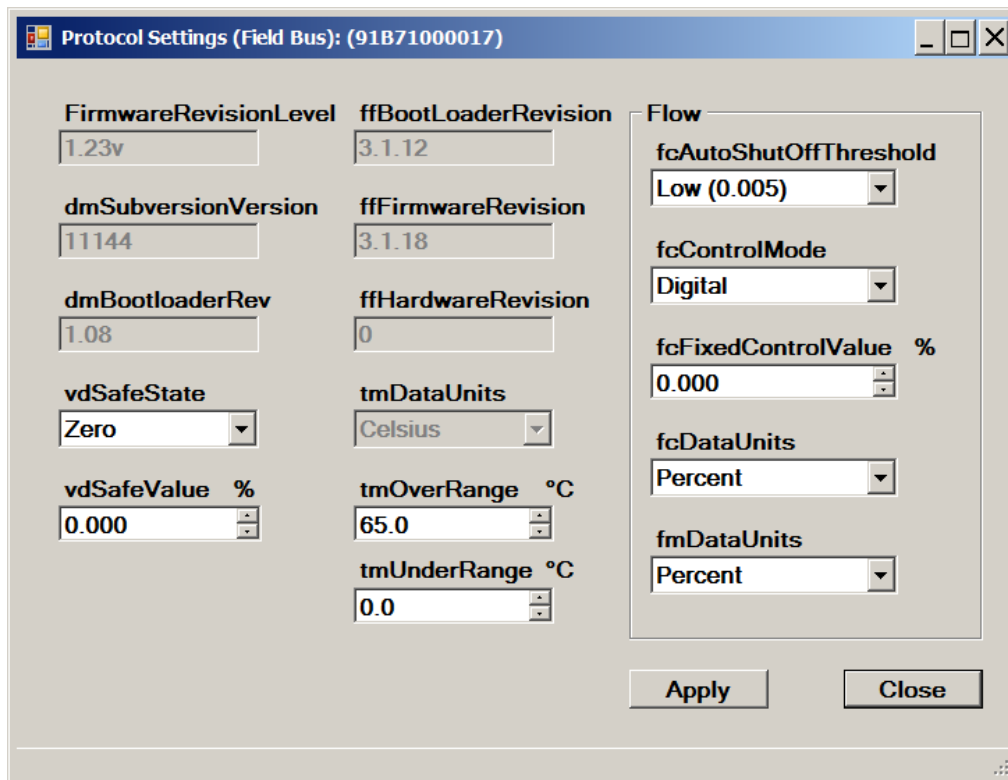

Figure 11-17 Protocol Settings (FieldBus) Window

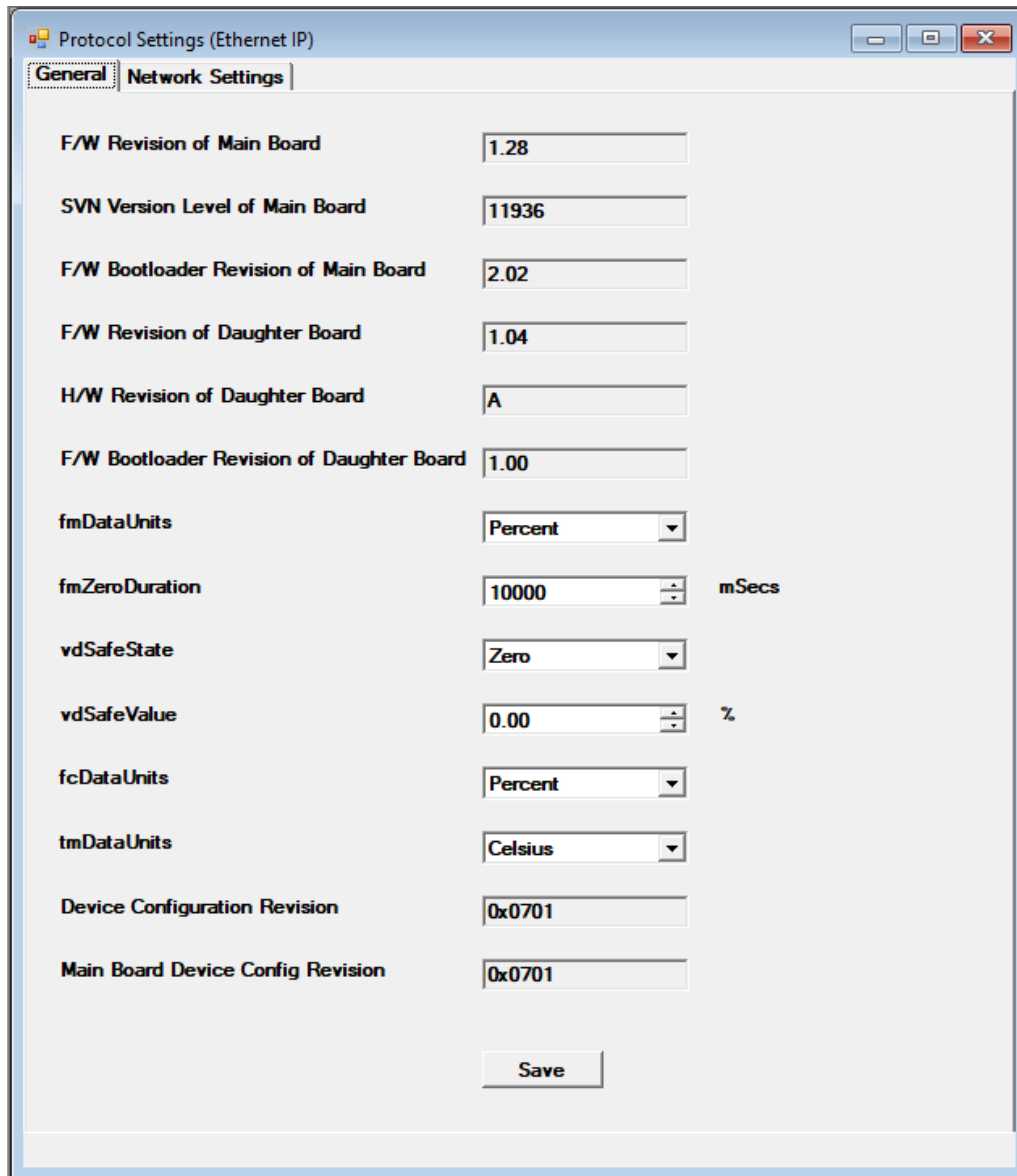

Figure 11-18 Protocol Settings (EthernetIP) Window, General Tab

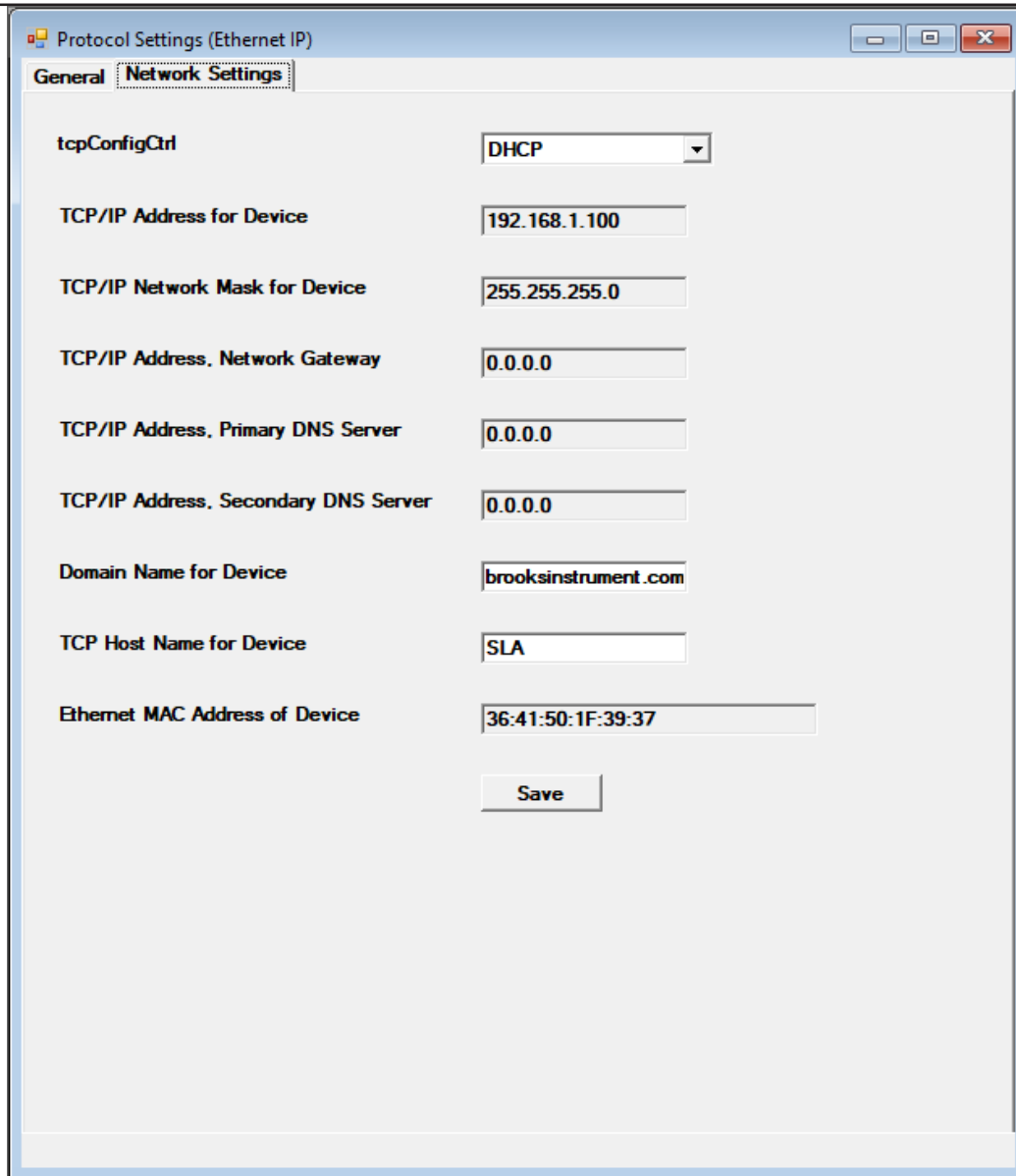

Figure 11-19 Protocol Settings (EthernetIP) Window, Network Tab

11.12 Warnings and Alarms

The software supports configuration of warnings and/or alarms for most device types. The exact alarms and warnings supported depends on the supported device type and options. Pressure-related warnings and alarms, for example, will only be supported by the PC and RT models. If the RS485 Analog customer interface with the S-Protocol supports flash codes, the MOD LED will flash the specified number of times if a certain alarm or warning is raised. This feature is not supported by other customer interface types. The DeviceNet customer interface also supports warnings in addition to alarms.

For more specific information on alarms, reference the specific device installation & operations manual and/or supplemental manuals.

Table 11-3 Event Conditions for Which Alarms/Warnings Can Be Set (SLA)

Event Condition	Model	Interface	Description
Program memory corrupt	MFC, MFM, PC, RT	RS485 Analog, FieldBus	Program memory checksum failure.
RAM test failure	MFC, MFM, PC, RT	RS485 Analog, FieldBus	Byte-by-byte test of RAM, detects bad memory location.
Non-volatile memory failure	MFC, MFM, PC, RT	RS485 Analog, FieldBus	Byte-by-byte test of non-volatile memory, detects bad memory location.
Internal power supply failure	MFC, MFM, PC, RT	RS485 Analog, FieldBus	Any internally generated power supply voltage outside operational limits. Internal supply voltages must be within their nominal limits.
Temperature Low/High	MFC, MFM, PC, RT	RS485 Analog	This condition occurs when the internal temperature is below the low limit or the internal temperature is above the high limit. Contact Brooks if there is a need to alter these low and high temperature limits.
Temperature Sensor Failure	MFC, MFM	FieldBus	Connection to the temperature sensor has been lost
Device calibration due	MFC, MFM, PC, RT	RS485 Analog	This condition occurs after the specified elapsed hours indicating that the device needs to be recalibrated. Default the corresponding hours limit is set to 8760 hours, equal to 1 year. The alarm will be cleared once either the alarm is disabled or the corresponding hours limit is set different from 0 in the Alarm Settings screen.
Device overhaul due	MFC, MFM, PC, RT	RS485 Analog, Profibus, DeviceNet	This condition occurs after the specified elapsed hours with gas flowing greater than 0.5%. The alarm will be cleared once either the alarm is disabled or the corresponding hours limit is set different from 0 in the Alarm Settings screen. Default this alarm is set to elapse in 8760 hours, equal to 1 year.
Setpoint deviation	MFC, MFM, PC, RT	RS485 Analog	An alarm/warning condition occurs if the difference between the set point and flow exceeds the specified limit.
Valve drive low/high	MFC, PC, MFC- RT	RS485 Analog, Profibus, DeviceNet	This condition occurs when the valve drive is below the low limit or above the high limit.
No flow indication	MFC, MFM, RT	RS485 Analog	This condition occurs if the measurement of flow indicates flow less than the specified limit value.
Negative flow indication	MFC, MFM	FieldBus	Flow has been detected in the negative direction below the limit.
Flow Low/High	MFC, MFM, RT	RS485 Analog, Profibus, DeviceNet	This condition occurs when flow is below the low limit or above the high limit.
Totalizer Overflow	MFC, MFM, RT	RS485 Analog	This condition occurs if the Flow Totalizer value exceeds its maximum value.
Flow Totalizer	MFC, MFM	FieldBus	User alarm flow totalizer has reached zero.
Time Totalizer	MFC, MFM	FieldBus	User alarm Time totalizer has reached zero.
Pressure Low/high	PC, RT	RS485 Analog, Profibus, DeviceNet	This condition occurs when the pressure is below the low limit or above the high limit.
Flow controller error band	MFC, RT	Profibus, DeviceNet	An alarm/warning condition occurs if the difference between the set point and flow exceeds the specified limit.
Pressure controller error band	PC, RT	Profibus, DeviceNet	An alarm/warning condition occurs if the difference between the set point and pressure reading exceeds the specified limit

11.13 Warning Settings

The Warning Settings window allows a user to change warning settings for the device. This is similar to alarm settings. Warnings are not supported on all devices. For GF40 and SLA Rev B EthernetIP device types, warning settings are accessed via the Alarm settings menu.

The Low Limit and High Limit are in terms of the units specified under the units column for each row.

***NOTE:** The user must click Apply for settings changes to take effect.

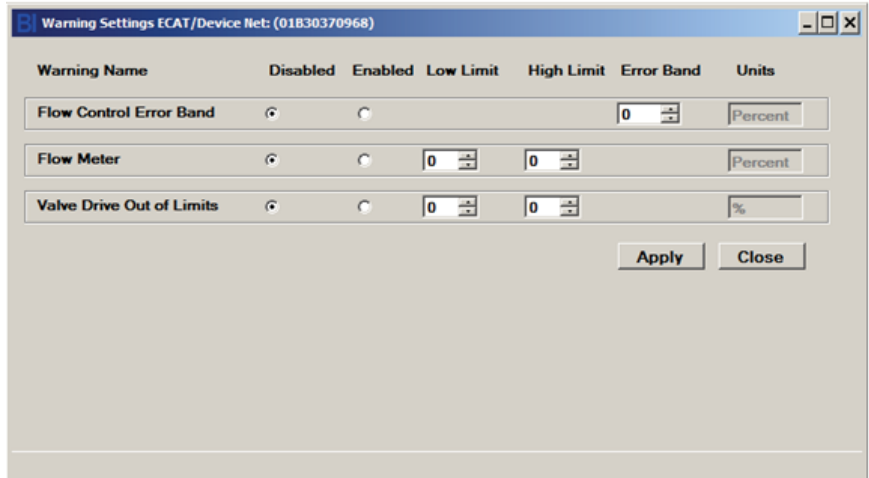

Figure 11-20 Warning Settings Window, Ethercat

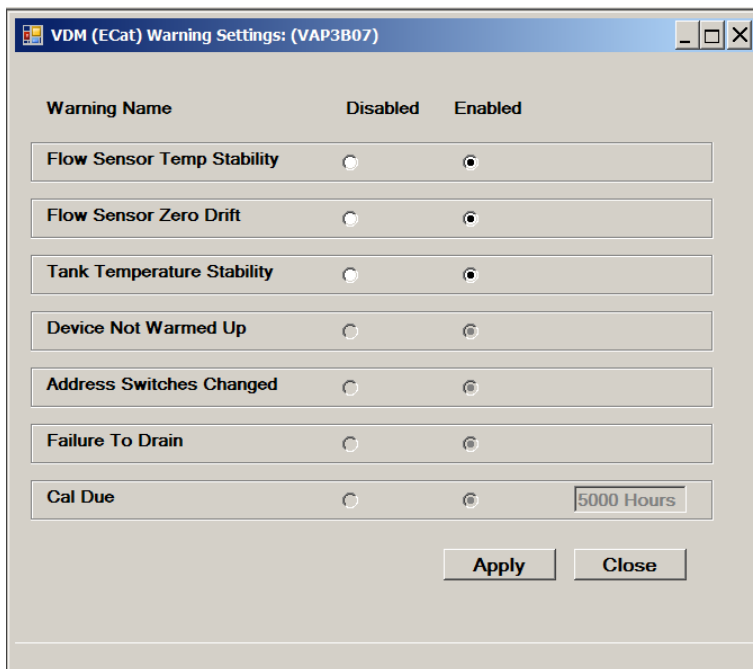

Figure 11-21 Warning Settings Window, VDM

11.14 Alarm Settings

The Alarm Settings window allows a user to change alarm settings for the device.

***NOTE:** The user must click Apply for settings changes to take effect.

The exact alarm settings window that appears depends on the type of device, as automatically detected by the software. Reference the device's supplemental user manual for more information about specific alarms.

The types of alarm settings windows are:

- RS485
- Profibus
- DeviceNet/EtherCAT.
- Foundation FieldBus
- EthernetIP
- GF40
- GP200
- GF1xx

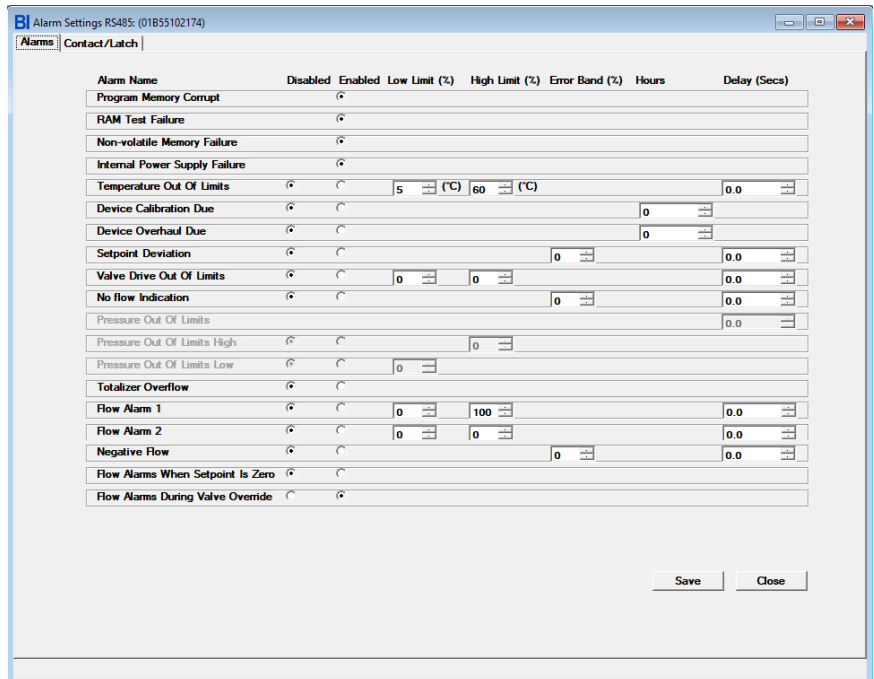

Figure 11-22 Alarm Settings RS485 Window, Alarms Tab
 (exact alarms settings available varies depending on device type)

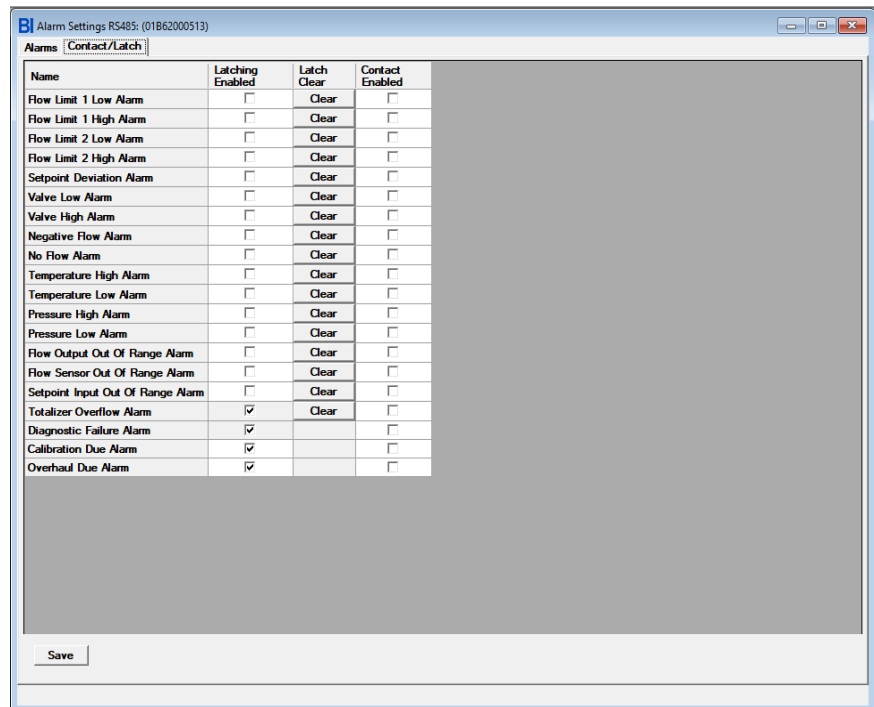

Figure 11-23 Alarm Settings RS485 Window, Contact/Latch Tab
 (exact alarms settings available varies depending on device type)

***NOTE:** For SLA device firmware prior to version 1.20, the Pressure Out of Limits Alarm Enable high and low are not independently settable. Either both are enabled or both are disabled (checking enable for one enables the other, and vice-versa).

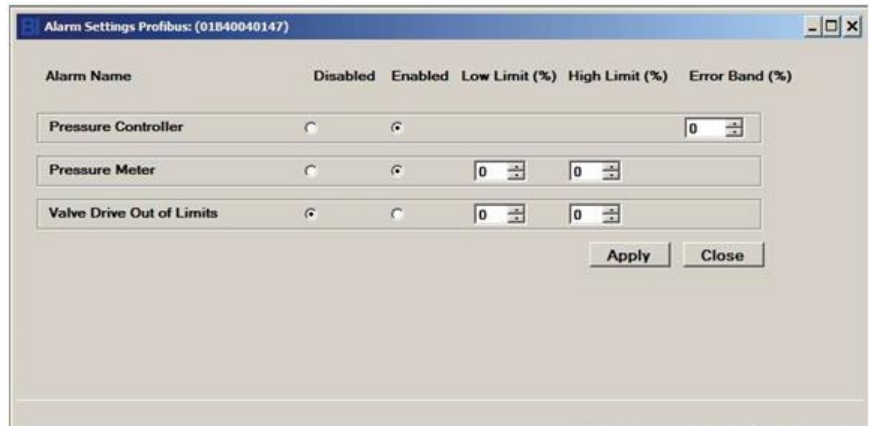

Figure 11-24 Alarm Settings Profibus Window
(exact alarms settings available varies depending on device type)

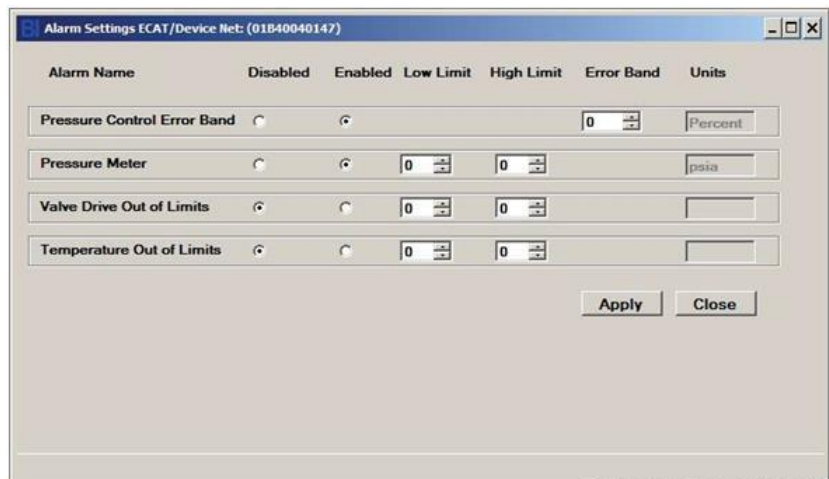

Figure 11-25 Alarm Settings DeviceNet/EtherCAT Window
(exact alarms settings available varies depending on device type)

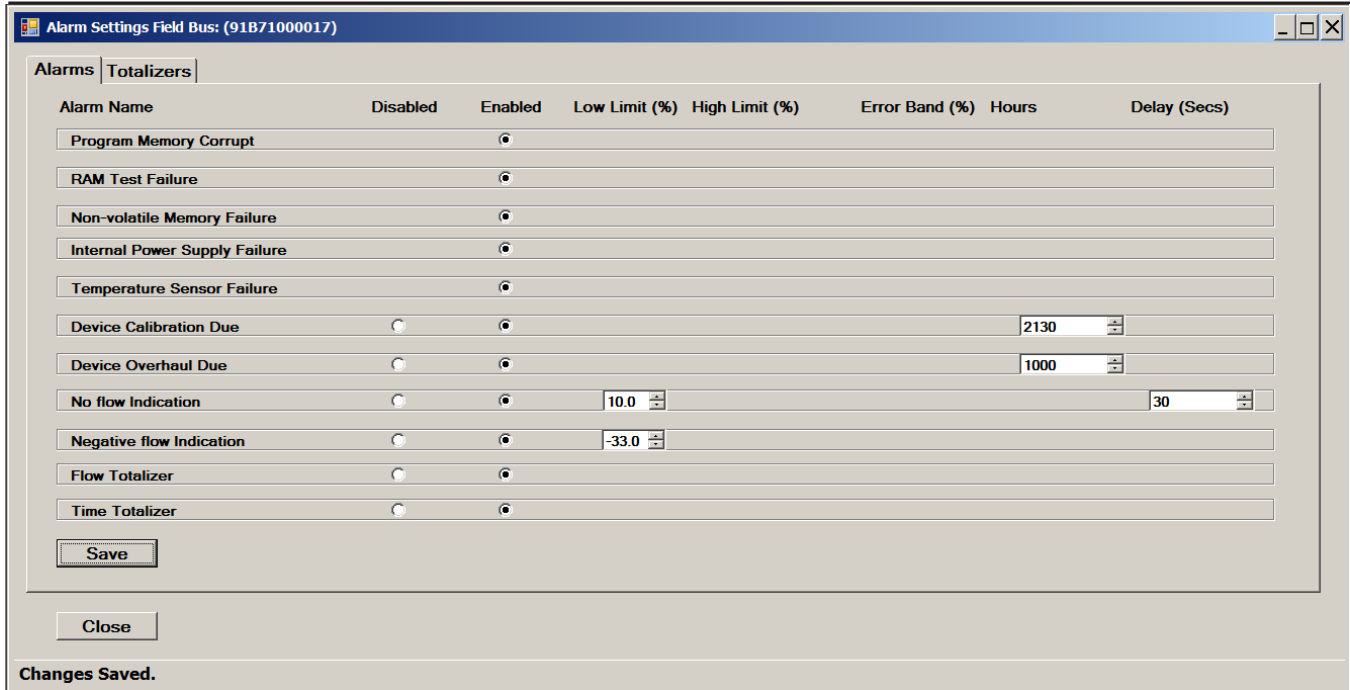

Figure 11-26 Alarm Settings (Field Bus), Alarms Tab

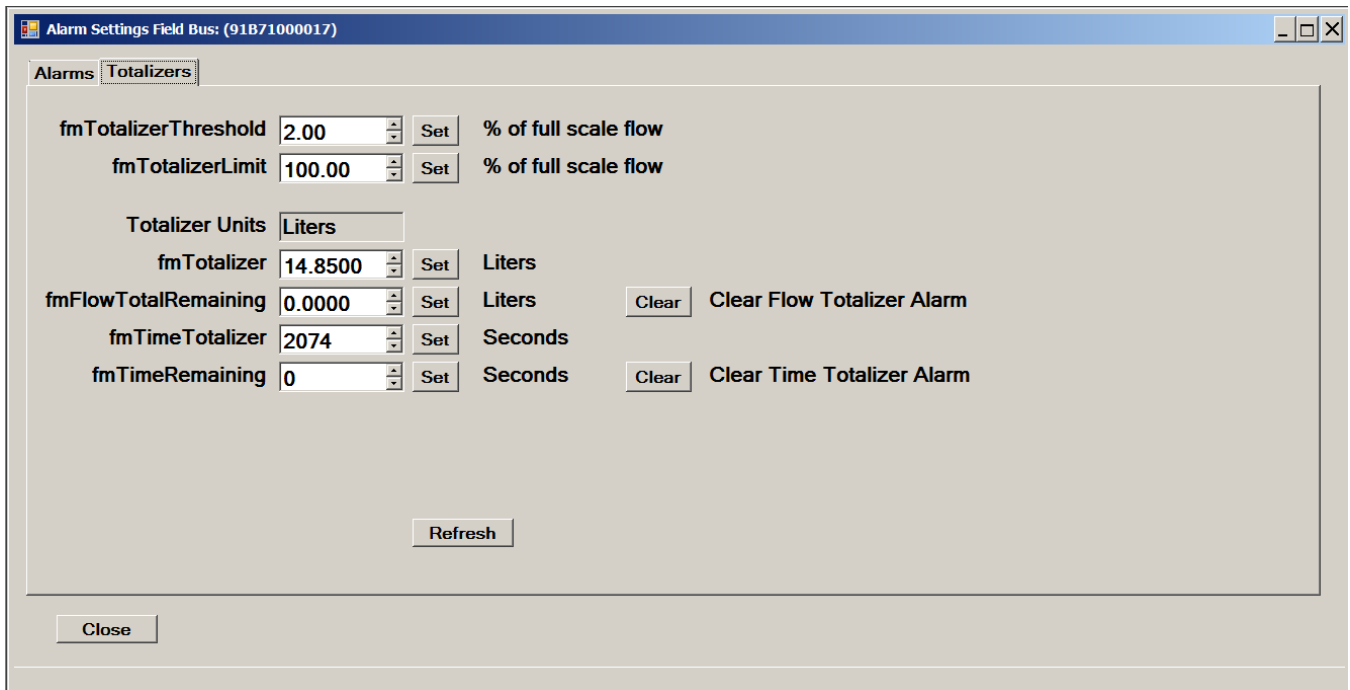

Figure 11-27 Alarm Settings (Field Bus), Totalizers Tab

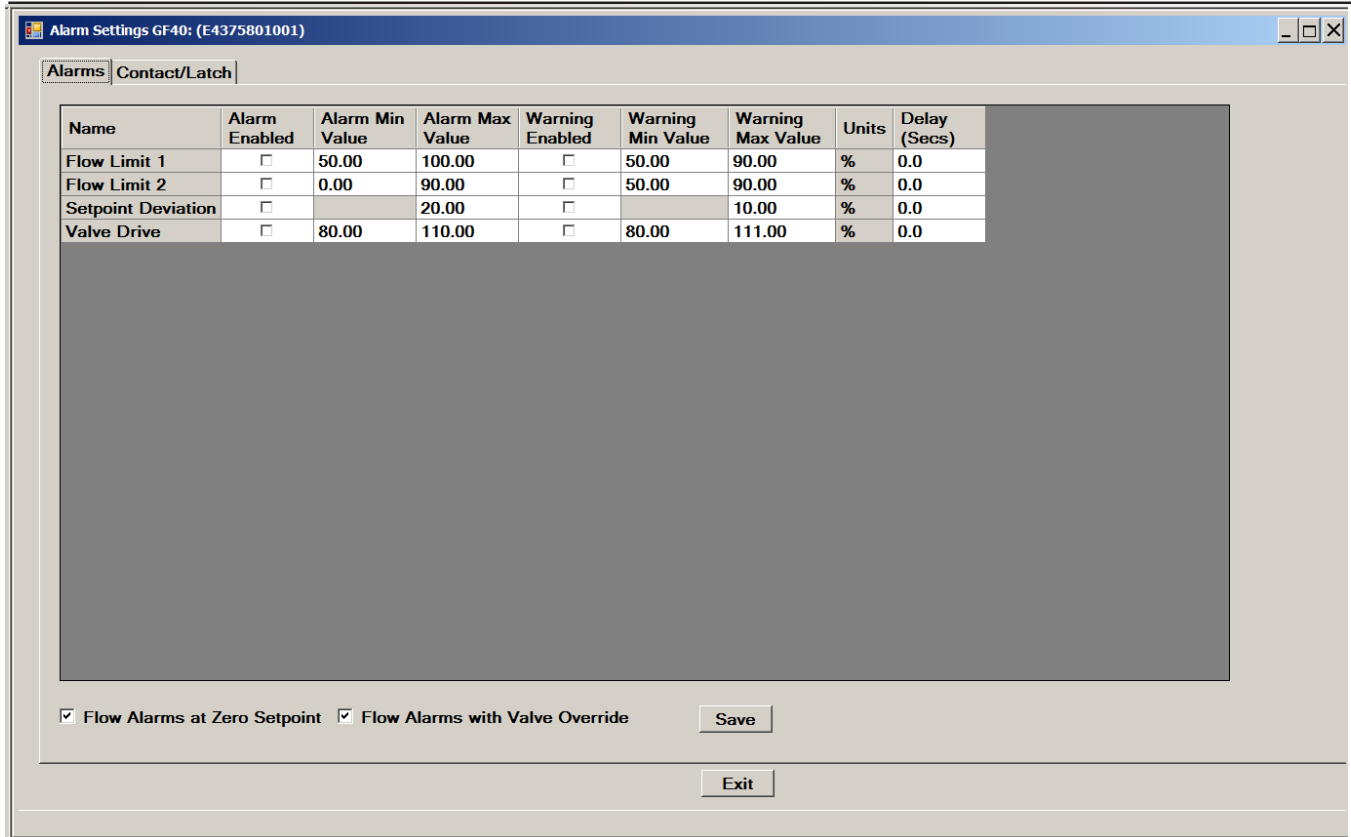

Figure 11-28 GF40 Alarm Settings, Alarms Tab

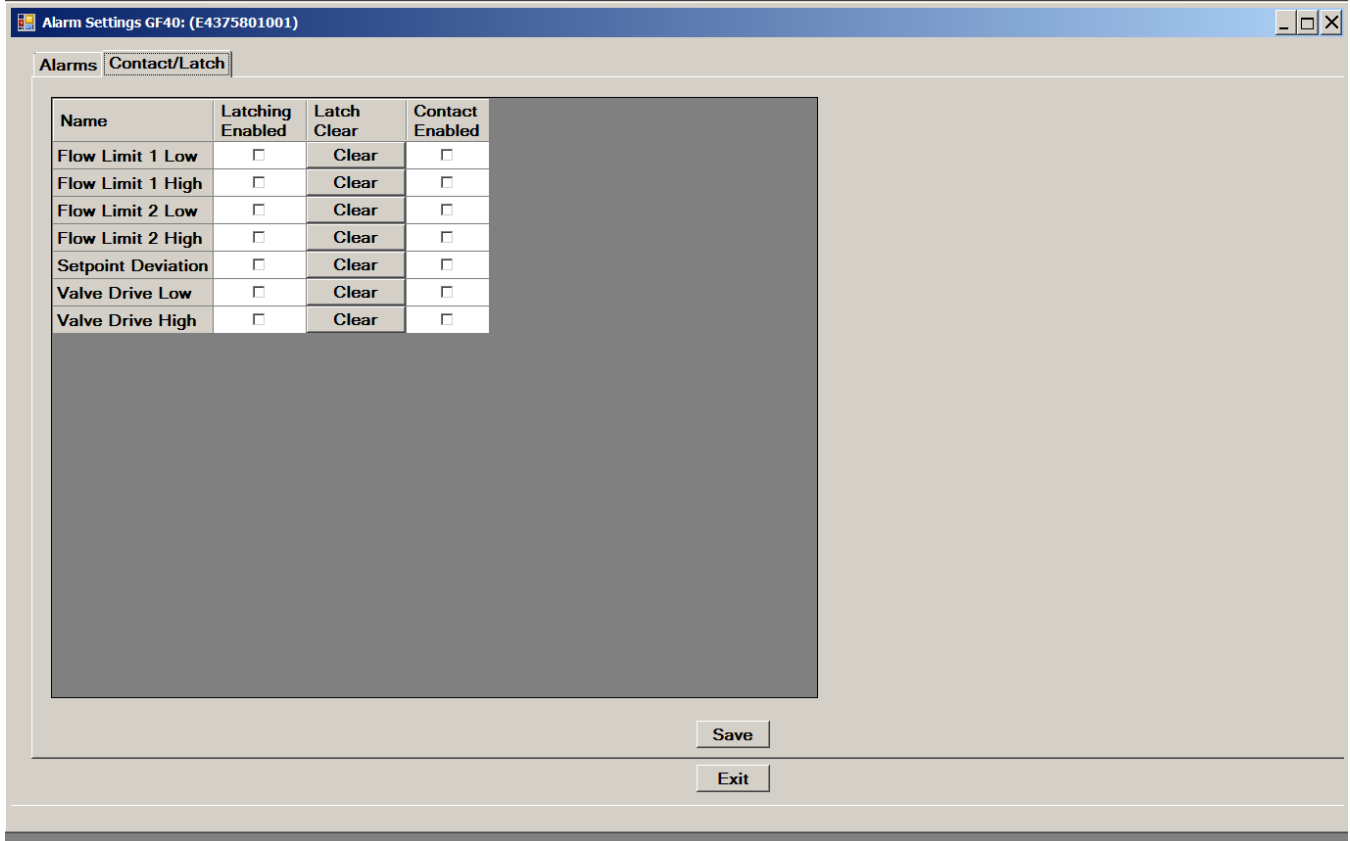

Figure 11-29 GF40 Alarm Settings Window, Contacts/Latch tab

GP200 Alarm Settings: (01B93602703)

Description	AlarmEnabled	LowLimit	HighLimit	Band	Units	Delay_mSecs
FLOWALARMHIGH	<input type="checkbox"/>		0		Counts	1000
FLOWALARMLOW	<input type="checkbox"/>	0			Counts	1000
PRESALARMHIGH	<input type="checkbox"/>		100.0		Counts	1000
PRESALARMLOW	<input type="checkbox"/>	0			Counts	1000
TEMPALARMHIGH	<input type="checkbox"/>		13672		Counts	1000
TEMPALARMLOW	<input type="checkbox"/>	16129			Counts	1000
CNTRLDEVALARM	<input type="checkbox"/>			0	Counts	1000
ACTALARMHIGH	<input type="checkbox"/>		2.0		Counts	
ACTALARMLOW	<input type="checkbox"/>	0			Counts	
FLOWWARNHIGH	<input type="checkbox"/>		0		Counts	1000
FLOWWARNLOW	<input type="checkbox"/>	0			Counts	1000
PRESWARNHIGH	<input type="checkbox"/>		100.0		Counts	2000
PRESWARNLOW	<input type="checkbox"/>	0			Counts	2000
TEMPWARNHIGH	<input type="checkbox"/>		15883		Counts	2000
TEMPWARNLOW	<input type="checkbox"/>	tmKelvins < tmWarningTripPointLow			Counts	2000
CNTRLDEVWARN	<input type="checkbox"/>			0	Counts	1000
ACTWARNHIGH	<input type="checkbox"/>		2.0		Counts	
ACTWARNLOW	<input type="checkbox"/>	0			Counts	

Digital IO
 sdsAlarmEnable sdsWarningEnable

Figure 11-30 GP200 Alarm Settings Window

EthernetIP alarm status screens not shown for brevity.

11.15 Restrictor Selection

The **Restrictor Selection** window guides a user in changing settings for device restrictors (for devices that support this feature – SLA Rev B only).

***NOTE:** Restrictor selection is an advanced topic. Most users will not need to use this feature. A Pro license is required to use this feature.

When you open the Restrictor Selection window, it shows the current restrictor part number, as well as all the valid restrictor selection options for your device. Each row in the grid represents a valid combination of settings with each restrictor part number. The current restrictor configuration is represented by the selected row in the grid. To select a new restrictor option, click on a new row to select it, then click Change (you must click Change for the change to take effect permanently). Click Optimal to allow the software to automatically choose the optimal restrictor (be sure that the model code is set correctly beforehand). Again, you must click Change for the change to take effect permanently.

For custom combinations of restrictor part numbers and other model code parameters use the Model Code window or contact the factory.

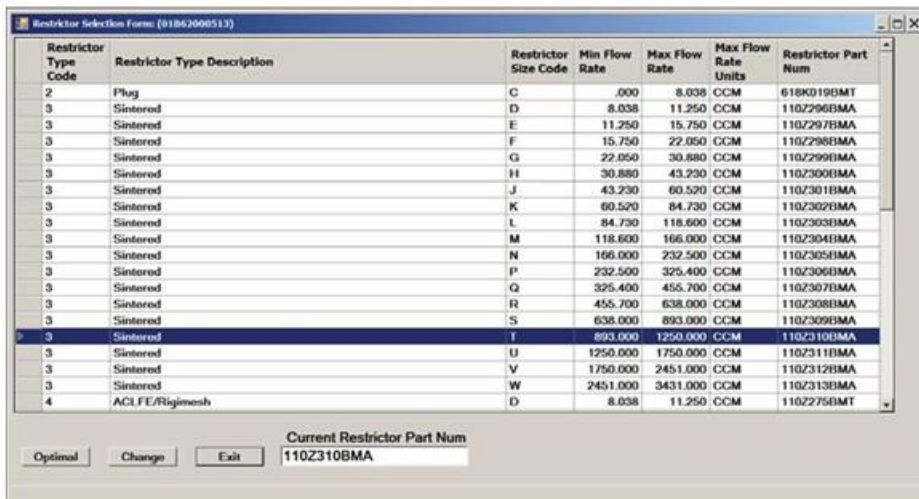

Figure 11-31 Restrictor Selection Window

11.16 Orifice Selection

The **Orifice Selection** window guides a user in changing settings for device orifice configurations (for devices that support this feature – SLA Rev B only). This is similar to the restrictor selection.

***NOTE:** Orifice selection is an advanced topic. Most users will not need to use this feature. A license is required to use this feature.

When you open the Orifice Selection window, it shows the current orifice part number, as well as all the valid orifice option selections. Each row in the grid represents a valid combination of settings with each orifice part number. The current orifice configuration is represented by the selected row in the grid. To select a new orifice option, click on a new row to select it, then click Change (you must click Change for the change to take effect permanently). Again, you must click Change for the change to take effect permanently.

For custom combinations of orifice part numbers and other model code parameters use the Model Code window or contact the factory.

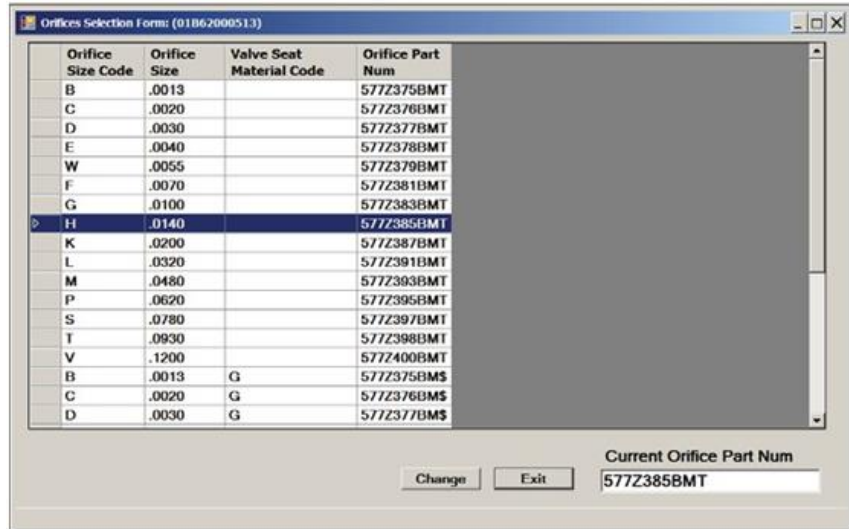

Figure 11-32 Orifice Selection Window

Chapter 12 Device Control Menu

The **Device Control** menu provides functionality to control a device with functions such as valve control, rebooting a device, and setting the device's executing mode.

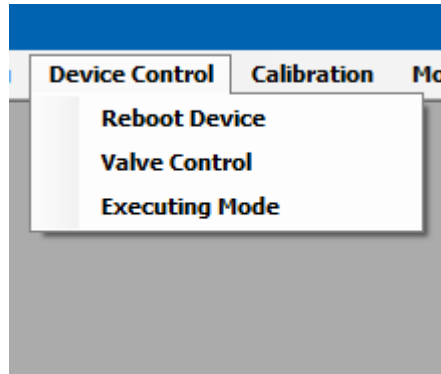

Figure 12-1 DeviceControl Menu

(executing mode appears only for supported devices).

12.1 Reboot Device

This window will allow a user to reboot a device. A reboot is similar to cycling the power to the device. If the user clicks reset, and confirms, the device will be reset and the device will remain attached to the software.



Figure 12-2 Reboot Device Window

12.2 Valve Control

The **Valve Control** menu provides functionality to directly control a device's valve. This is not available for meter (MFM) devices, as they do not have valves.

If control is set to Analog (external), the software will ask if the user wants to set control to Digital (BEST) control. See **Figure 11-2**.

In normal operation, a device's valve may freely move up and down to regulate the flow or pressure of the controller device. However, the **Valve Control** feature allows the user to directly take control of the valve position.

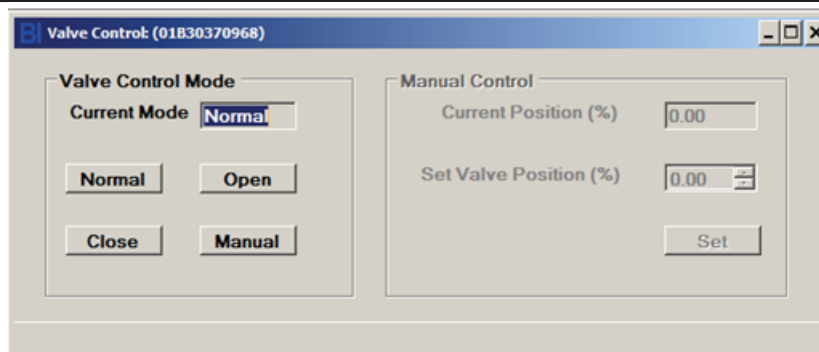

Figure 12-3 Valve Control Window

First, the user selects the desired valve control mode. The current valve control mode is shown on the window.

Normal mode is when the valve automatically moves up and down to regulate flow or pressure.

Open is when the valve is forced fully open. Closed is when the valve is forced fully closed.

Manual is when the user can select a valve position from 0 to 100%. When manual is selected, the Manual Control box on the right side of the form becomes enabled. The user can view and set the valve position (the user must click the Set button or click Set on the Up/Down numeric control).

The valve will then be held at this position.

***NOTE:** if the user is using an external controller (such as the Brooks 0254) and that controller has its valve override enabled, BEST's valve control mode may not be able to change the mode or position.

When the user closes this window, if the mode is not in normal mode, the software will ask the user if they want to set the mode back to normal before leaving the window, as a reminder. Normal mode is required for most other functions.

For the VDM300 device, valve position (%) is replaced with Valve Current (mA). This current value is approximate.

12.3 Executing Mode

If a device supports this feature, this menu allows a user to control the operating mode of device (executing mode, or Idle/Safestate). Some device types use “Idle” mode instead of “Safestate”.

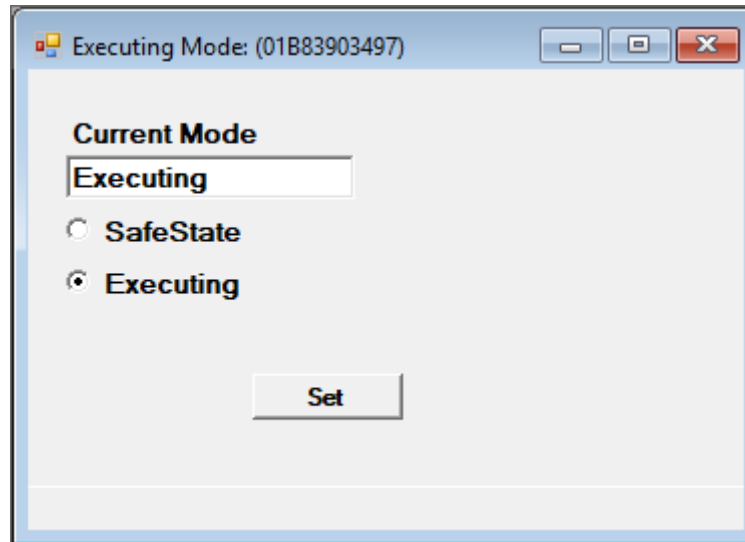

Chapter 13 Calibration Menu

The **Calibration** menu provides access to the process of calibrating and tuning a device. Customer devices are usually calibrated from the factory. However, BEST allows an advanced user to calibrate a device.

A software license is required for most calibration functions. Reference [Table 2-4](#) through [Table 2-9](#) to determine if calibration features are supported on your device.

Both flow and pressure devices need to be calibrated for accurate control and measurement. The calibration menu includes functions for sensor zero, flow and pressure calibration, valve and response tuning, and analog input and output tuning.

Calibration is the most complex aspect of BEST software.

CAUTION: Some of the features contained within the Calibration menu can be used to alter the performance of the device. It is recommended that you save the device configuration before proceeding with any calibration or tuning function. For instructions on how to save the device configuration, refer to [Section 11.2](#).

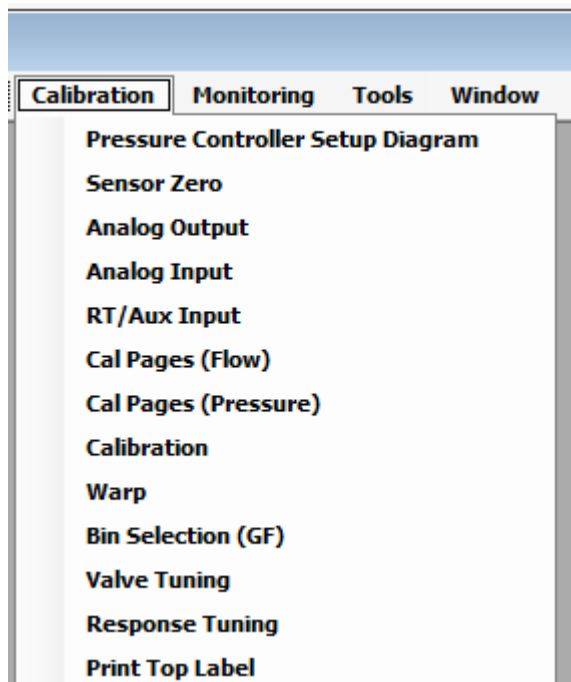

Figure 13-1 Calibration Menu
(exact options/features shown may depend on device type).

***NOTE:** Before conducting any calibration menu operations, verify the model code is set correctly (see [Section 11.5](#)).

13.1 Pressure Controller Setup Diagram

The Pressure Controller Setup Diagram menu displays a basic setup diagram for pressure controller and RT devices. The diagram shows typical setups for an upstream and a downstream application. These diagrams are from the device manual but are available directly from the software as a convenience. These are merely suggested/typical setups for reference – for detailed system analysis consult the device user manual or contact Brooks Instrument.

The window also indicates the configured direction (upstream or downstream) of the current device (See [Figure 13-2](#)).

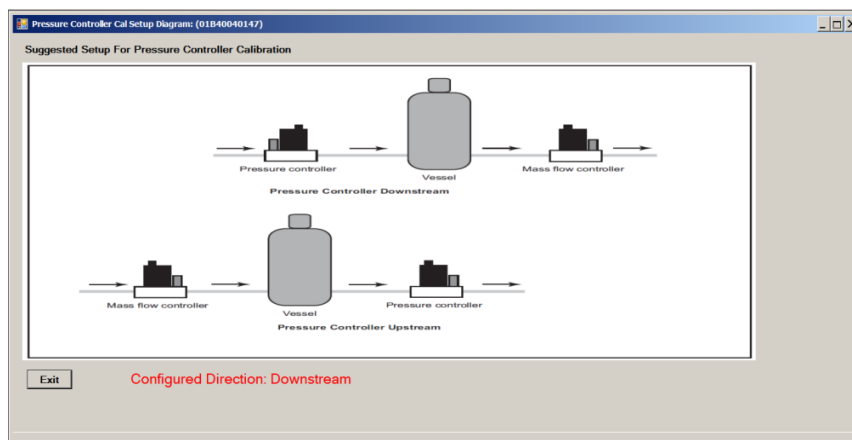

Figure 13-2 Pressure Controller Setup Diagram

13.2 Sensor Zero

The Sensor Zero menu guides the user through a sensor zero operation on either the device's flow sensor or pressure sensor, depending on the device type. In most cases, the software automatically detects the device type and sensor type, and displays the appropriate form and performs the corresponding routine (flow and pressure sensor zero operations are different operations but the forms have a similar appearance).

A sensor zero operation should be performed prior to a full calibration. See the device user manual.

13.3 Flow Sensor Zero

A flow sensor zero operation is performed for a MFC, MFM, or RT device (or possibly a PC device that has a flow sensor) in flow control mode. During the flow sensor zero operation there must be no flow through the device. During the zero operation, the operation reads the current sensor value, and offsets it so that the reading becomes zero.

***NOTE:** A flow device typically also includes a Zero pushbutton. The software performs the same function as the pushing that pushbutton.

To zero the device's sensor:

1. Allow the device to be powered on for a sufficient length of time (reference the specific device manual) so that it achieves its stabilized operating temperature.
2. Close the downstream shutoff valve, if present.

The device should be full of process gas with no pressure differential.

3. Wait at least 30 seconds for the flow signal to drop to zero.
4. Using the device's Zero pushbutton or the Brooks Expert Support Tool's SensorAdjust function, zero the device.

If using the pushbutton, press the pushbutton, then release it. If using the software, access the menu item Calibration->Sensor Zero.

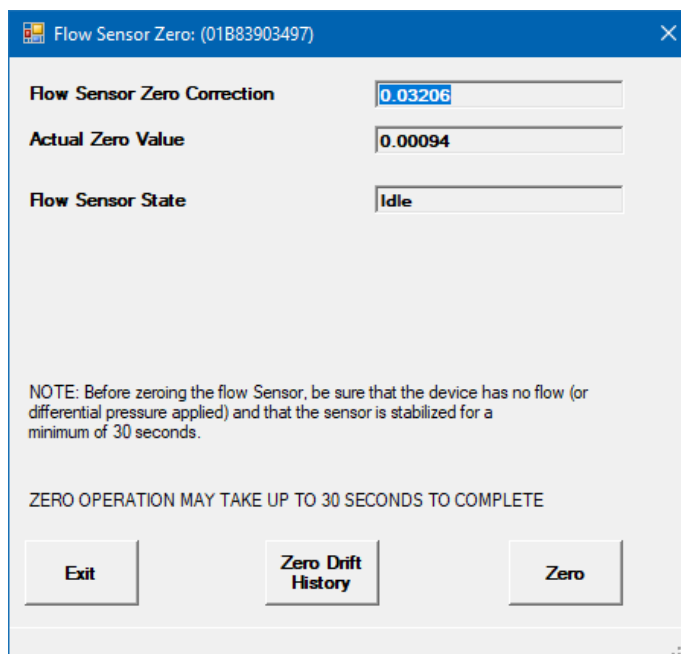

Figure 13-3 Flow Sensor Zero Window
(Zero Drift History button appears only for EthernetIP devices).

In the flow sensor zero window (Figure 13-3), the Actual Zero Value is the current (“live”) flow measurement of the flow sensor. The Flow Sensor Zero Correction is the current correction offset. The Flow Sensor State is “Idle” while the zero operation is not processing.

With no flow present, click the Zero button. The state changes to “InProgress” while the zero operation takes place. The process may take up to 15 seconds. When completed, it returns to “Idle”.

If you attempt to zero the device while gas is flowing at 5% of full-scale, a dialog box displays, prompt you to confirm whether you want to continue with the operation.

***NOTE:** For SLA devices, there is another way to access the flow sensor zero operation, under the Calibration->Calibration menu (see Figure 13-26). Both of these access methods perform the same flow sensor zero operation, except that the Calibration->Calibration menu method gives the user the option of performing a purge (opens the valve temporarily for 5 seconds) to relieve any trapped pressure.

Zero Drift History: For SLA Rev B EthernetIP devices only, the Zero Drift History information may be viewed. The history report may be viewed, printed, and saved to a file.

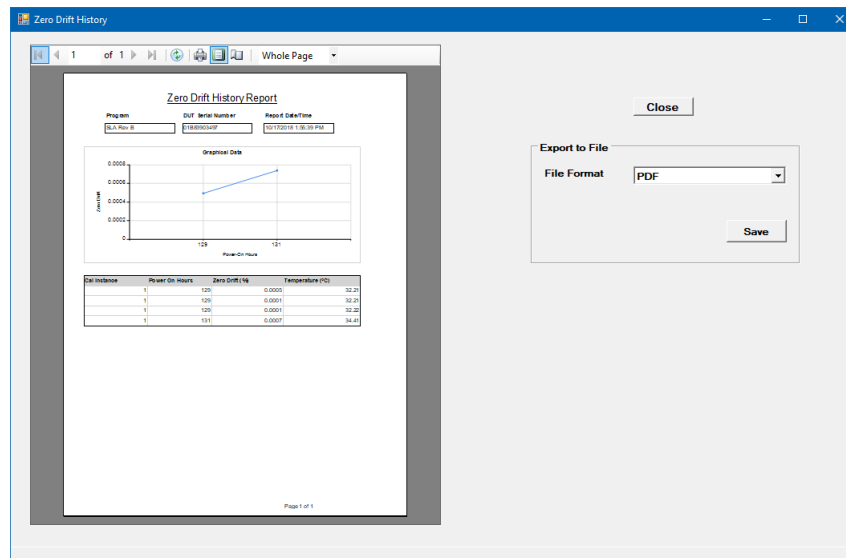

Figure 13-4 Zero Drift History Window

13.4 Pressure Sensor Zero

A pressure sensor zero operation is performed for a PC device only.

***NOTE:** While an RT device does measure pressure, it measures pressure with an external (remote) pressure sensor connected to the device. This external sensor is not zeroed by BEST software - it is assumed that the sensor's range (0-10V or 0-5V) represents its full specified range and that 0V = 0 pressure. see [Section 13.7](#) for calibrating the range of this external RT sensor.)

There are several ways to access the pressure sensor zero operation: the zero pushbutton, under this menu (Calibration->Sensor Zero) and for SLA devices, the Calibration->Calibration menu (see [Section 13.16](#)). These access methods perform different methods of sensor zero operation as explained below.

A pressure controller's pressure sensor can be calibrated in three ways:

- 1.) Use the physical reset button on the device
- 2.) A straight offset correction (BEST software, Calibration->Sensor Zero menu)
- 3.) An interpolated correction (BEST software, Calibration->Calibration menu – see [Section 13.16](#))

A pressure device includes a zero pushbutton (located at the side of the device) that performs a straight offset correction. For pressure devices with a psia sensor, this zero is assumed to be at absolute zero pressure (0 psia) which requires a vacuum. For pressure devices with a psig sensor, this zero is assumed to be at ambient pressure (0 psig).

The straight offset method for pressure controllers is similar to a flow sensor zero method. It is a simpler method than the interpolated method, but must be performed at reference pressure - under a vacuum for psia sensors or at ambient for psig sensors.

The interpolated method can be performed for devices with a psia sensor. This allows a psia sensor to be zeroed without actually applying a vacuum, although it is a more complicated process. This method is performed under the Calibration->Calibration menu item (see [Section 13.16](#)).

Simple Offset Zero

As this menu performs the simple offset method, it gives a warning for psia sensors. When the user clicks on the sensor zero menu (with a pressure controller device attached), the following warning is displayed:

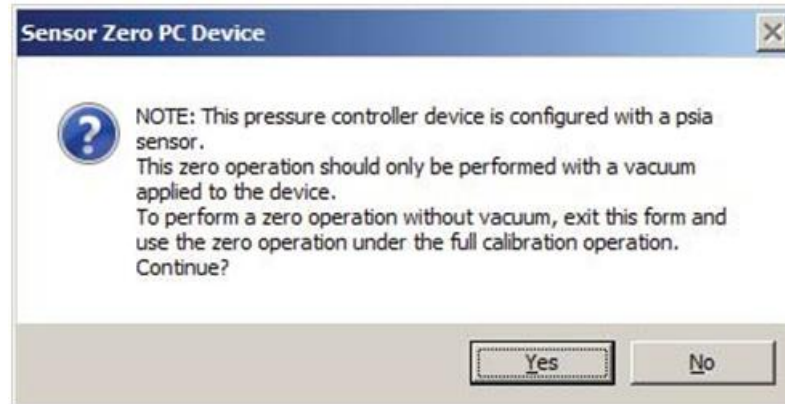

Figure 13-5 Sensor Zero Window for psia Pressure Device, PSIA Warning

After this, the pressure sensor zero window appears (see [Figure 13-6](#)). From this point forward, the zero operation is straightforward and is the same as the flow sensor zero operation.

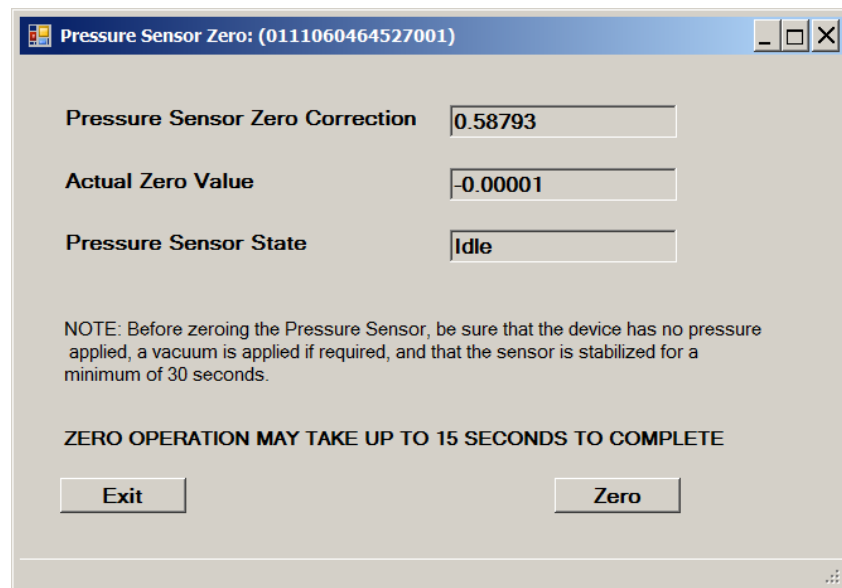

Figure 13-6 Pressure Sensor Calibration (Straight Offset Method)

Interpolated Zero Correction: see [Section 13.16](#).

13.5 Analog Output Calibration

The Analog Output Calibration menu guides the user in calibrating (or “tuning”) the analog output of the device, if it has an analog I/O option. The analog output provides a DC voltage or current proportional to the flow or pressure reading of the device. The range and type of output is a device option. The Calibration->Analog Output menu allows the user to select the mode/range, check the adjustment, change the adjustment, and set the Low Output Cutoff.

The Output Adjust window allows users to select the analog output mode and set output configuration parameters.

A typical setup for calibrating an output voltage is shown in Figure 13-7 and an output current in Figure 13-8. See your device’s user manual for specific information about your device. Contact Brooks Instrument to obtain a breakout board for easy connections. An alternative would be to use a device such as a Brooks Instrument Model 0254.

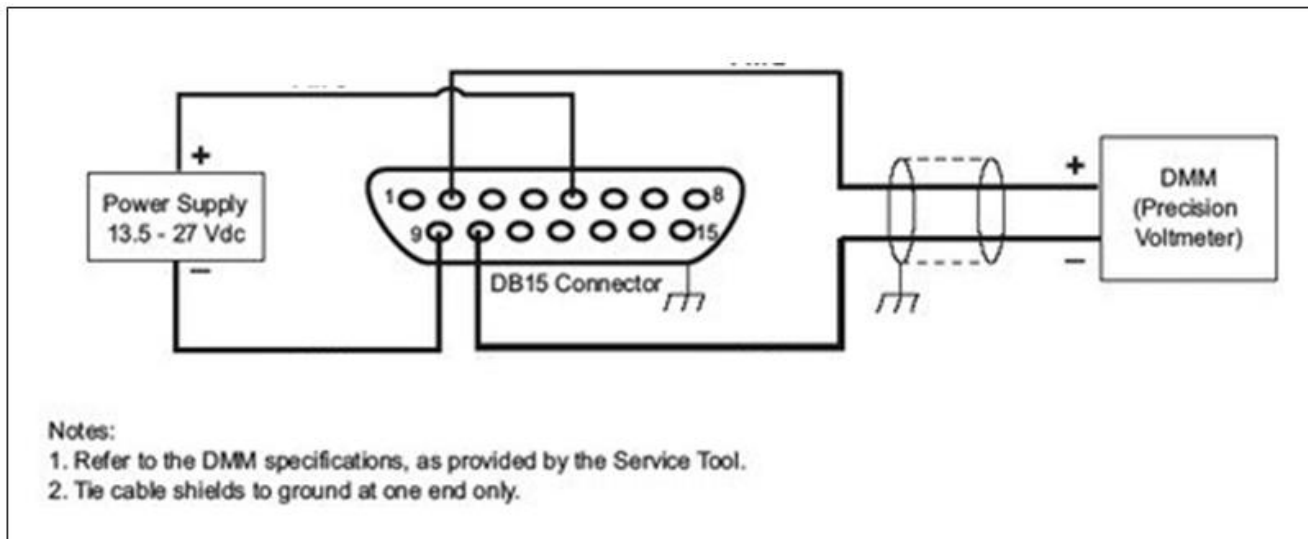

Figure 13-7 Typical Setup for Calibrating an Output Voltage

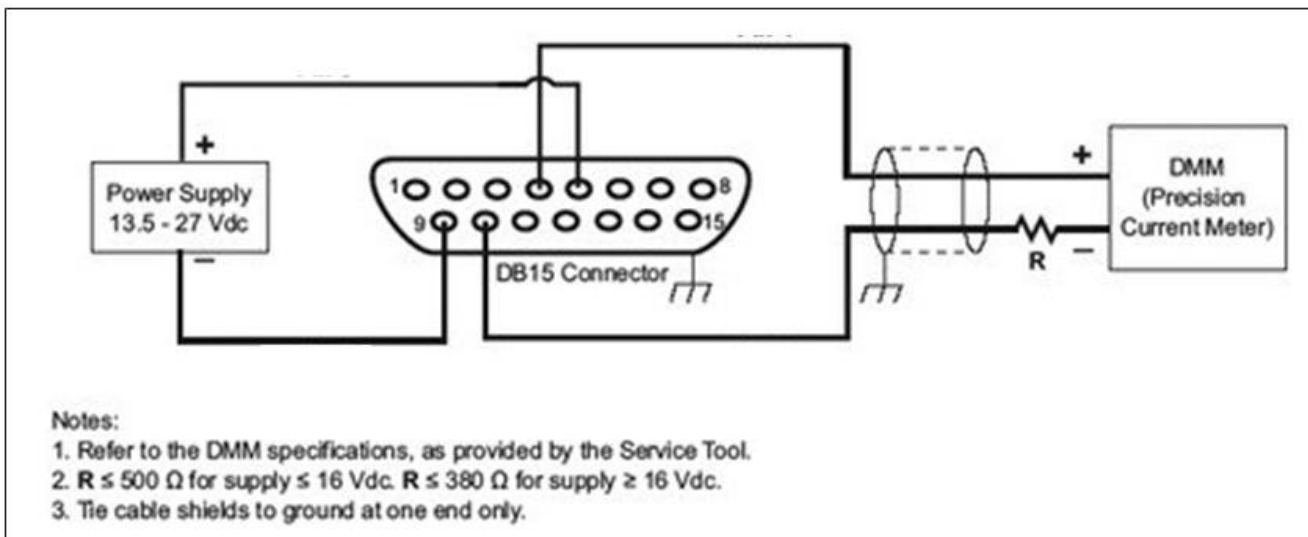

Figure 13-8 Typical Setup for Calibrating an Output Current

The Low Output Cutoff is a percentage of full-scale reading below which the analog output is forced to zero volts. For example, if the Low Output Cutoff is set to 5% and an MFC device is reading 4% flow, the analog output will put out 0 volts. To disable this feature, set Low Output Cutoff to 0%.

The user can change the Output Configuration mode by clicking on one of the five range buttons (if supported by the device). The current mode is shown in the Current Mode text box (See Figure 13-9).

The user can check the current analog output calibration by clicking on the Check button. Then the software will display another window (See Figure 13-10), asking the user to specify a voltage or current. Enter a voltage or current (within the range of the current analog output mode) and click Set. Then verify the voltage as read by an external measuring device (such as a multimeter or Brooks Instrument Model 0254 controller).

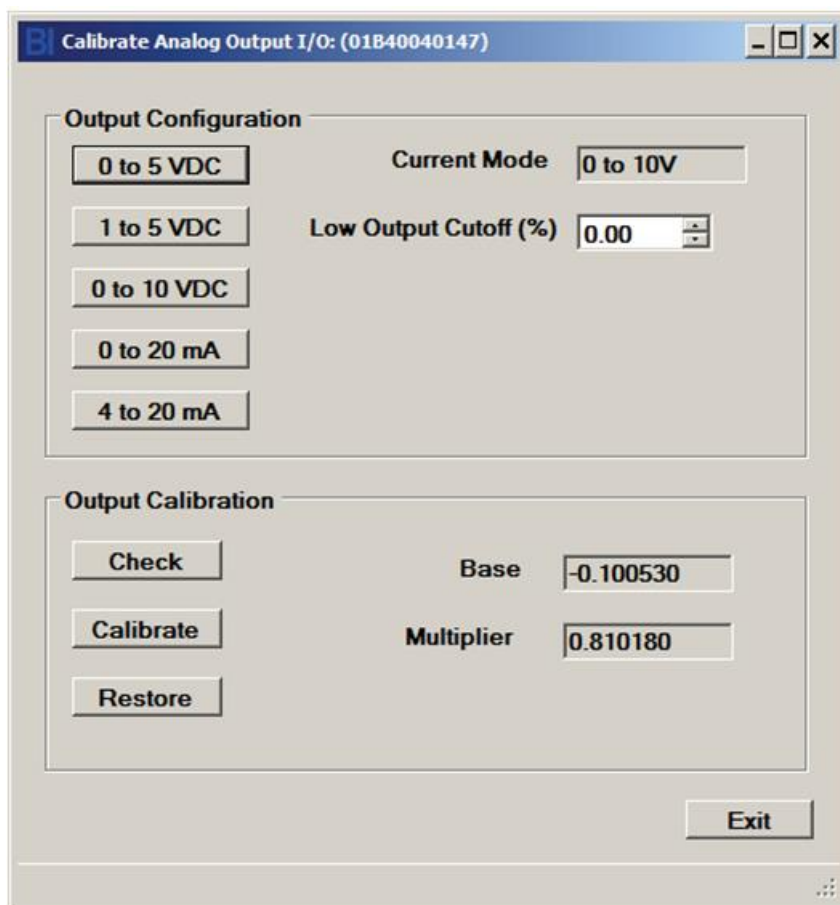

Figure 13-9 Analog Output Calibration Window

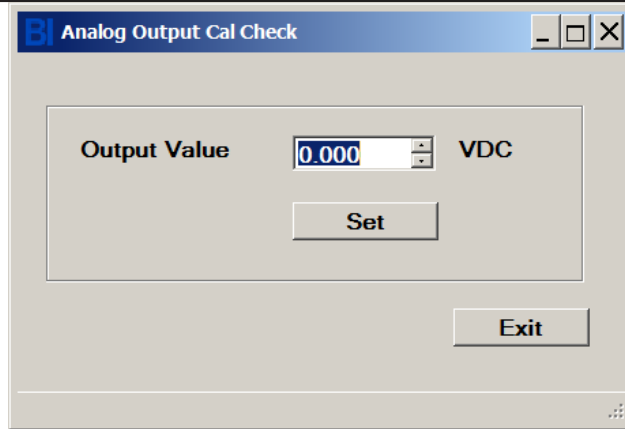

Figure 13-10 Analog Output Check Window

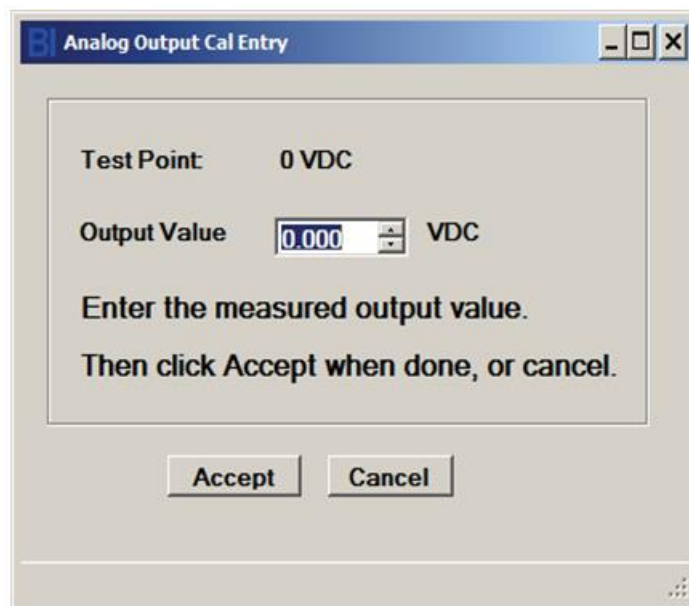

Figure 13-11 Analog Output Cal, Low Point

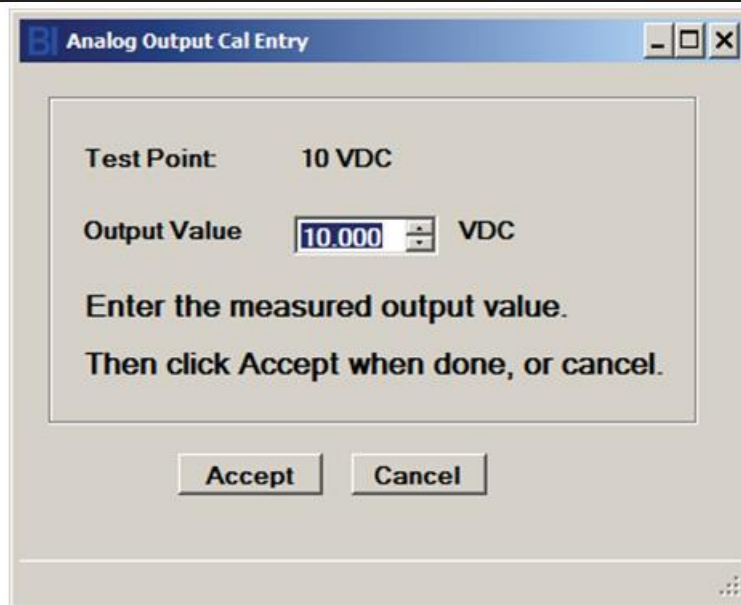

Figure 13-12 Analog Output Cal, High Point

The user can calibrate the analog output by clicking on the Calibrate button. The calibration process causes the device to output voltage or current at two values, then performs an interpolation to calculate an offset and factor (or, “base” and “multiplier”).

At each of the two points (low and high), read the voltage or current on an external measuring device, manually enter the value into the software window and click Accept.

Afterwards, the Base and Multiplier values will be updated.

The user may revert back to the original values of all parameters (when the Analog Output form was last opened) by clicking the restore button.

For SLA Rev B devices, select the mode before performing the calibration. Changing the mode after calibration may invalidate the calibration and require a re-calibration. For GF40 devices, the mode may be changed after calibration, if not changing the mode from voltage to current or vice-versa, without requiring a re-calibration. For GF40 devices, analog input and analog output modes must match.

13.6 Analog Input Calibration

The Analog Input Calibration menu guides the user in calibrating (or “tuning”) the analog input of the device, if it has the analog I/O option. If the device’s Control Source is set to Analog (see Section 8.4), the device responds to an analog input as either a DC voltage or current, changing its flow or pressure set point proportionally to the voltage or current. The range and type of input is a device option.

The Analog Input Calibration menu allows the user to select the mode and range, check the adjustment, change the adjustment, set the Softstart Ramp Time, and set the Low Input Cutoff.

The Input Adjust window allows you to select the analog input mode and set input configuration parameters. Before you begin, perform a sensor zero operation.

Note: For MFC and MFM models, the 0 to 10 VDC analog input mode is only supported with the RS485 Analog customer interface and must be ordered with the 0 to 10 VDC analog I/O mode option specified.

A typical setup for calibrating the analog input for voltage is shown below in Figure 13-13 and for current in Figure 13-14. See your device user manual for specifics about your device connections. Contact Brooks Instrument to obtain a breakout board for easy connections. An alternative would be to use a device such as a Brooks Instrument Model 0254.

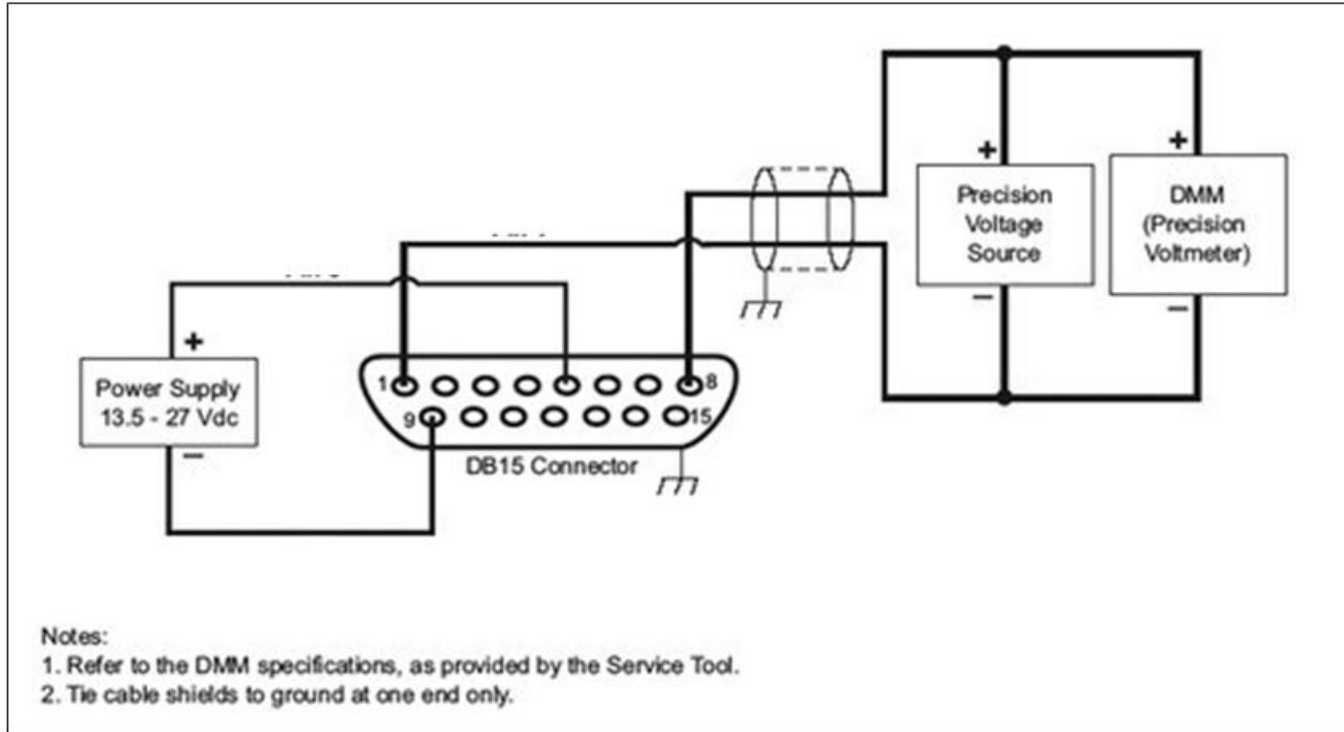

Figure 13-13 Typical Setup for Calibrating an Analog Input for Voltage

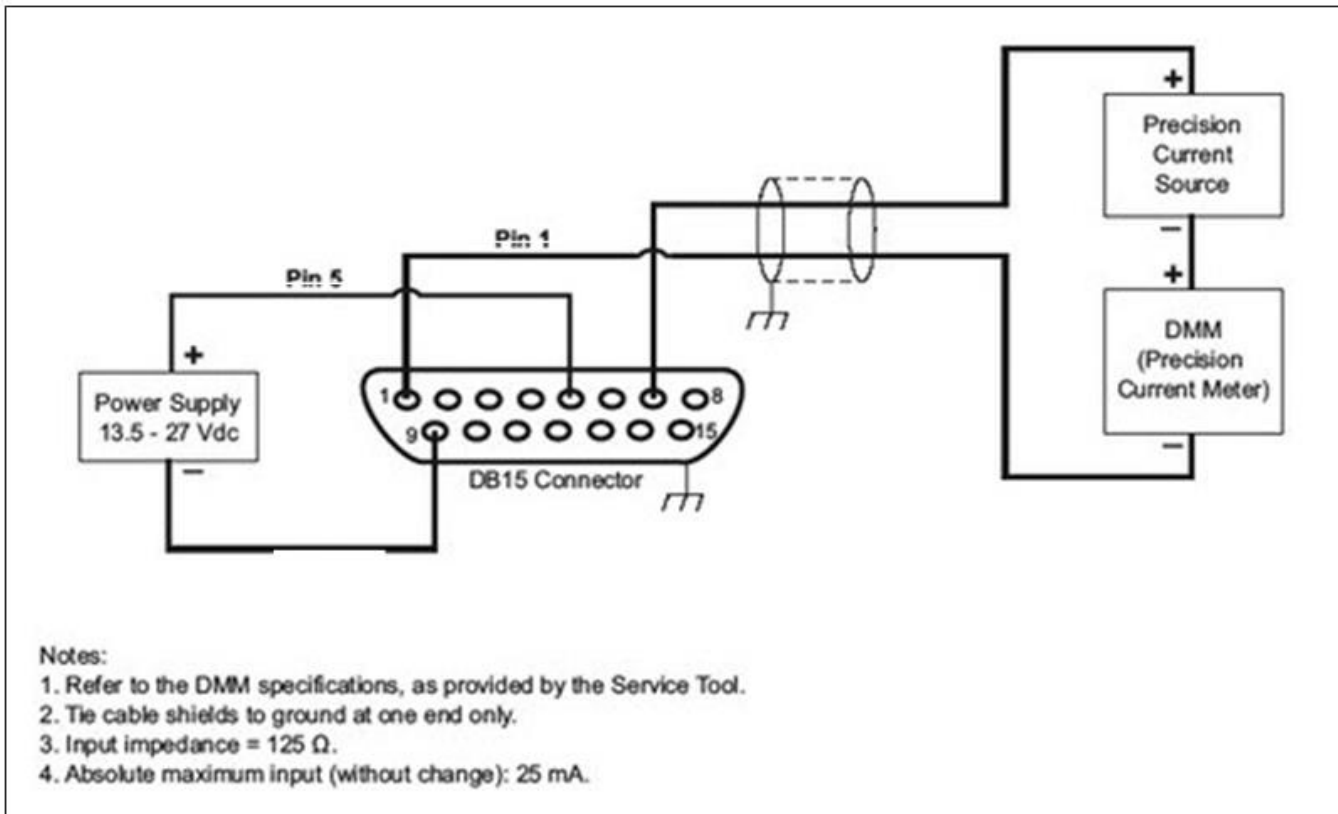

Figure 13-14 Typical Setup for Calibrating an Analog Input for Current

The Low Input Cutoff is a percentage of full-scale reading on the analog input below which the device set point is forced to zero. For example, if the Low Input Cutoff is set to 5% and the analog input is at 4%, the set point will be set to 0. To disable, set Low Input Cutoff to 0%.

The Softstart Ramp Time parameter allows user to ramp the set point in a certain time period specified in milliseconds (mS). For default behavior, set this parameter to 0 to allow for the fastest possible set point ramp time.

The user can change the Input Configuration mode by clicking on one of the five range buttons. The current mode is shown in the Current Mode text box.

The user can check the current analog input calibration by providing a voltage or current with an external source (such as a power supply or Brooks Instrument Model 0254 controller) to the device's analog input, then viewing the measured input "live" level in the Measured Input text box.

***Note:** Sometimes the valve may oscillate during the time between adjusting setpoint input base and multiplier. This is a normal event that will resolve itself immediately after setpoint input multiplier is adjusted.

The user can calibrate the analog input by clicking on the Calibrate button. The calibration process prompts the user to supply external voltages or currents to the device's analog input at two levels (high and low), then performs an interpolation to calculate an offset and factor (or, "base" and "multiplier").

At each of the two points (low and high), supply an external voltage or current as directed. The live voltage or current is shown in the Measured Input text box. Click Accept when ready each time.

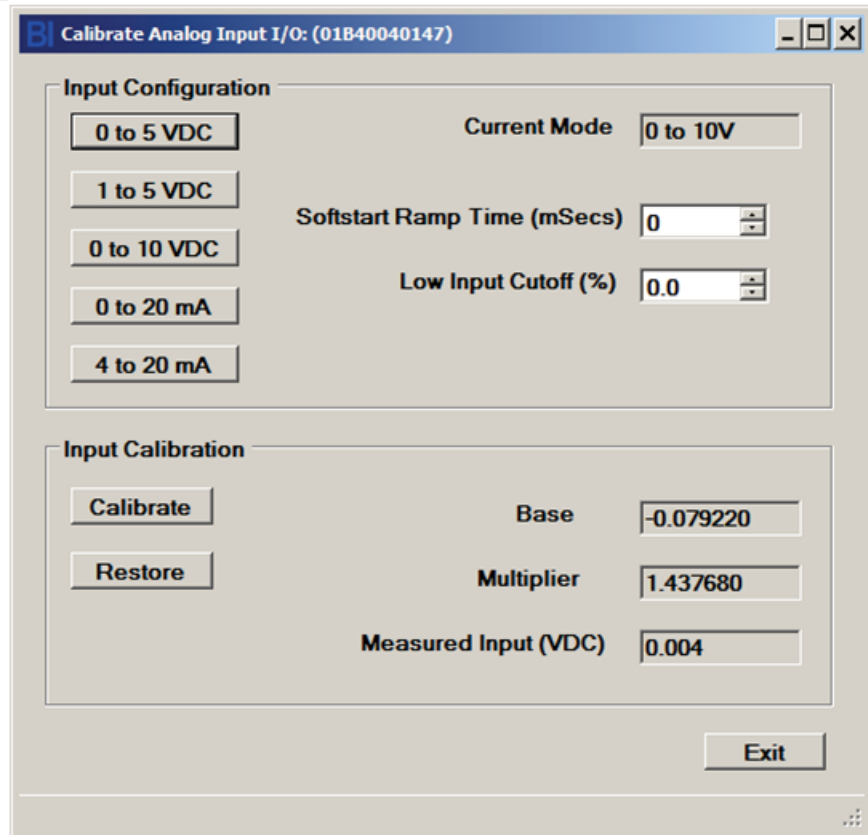

Figure 13-15 Analog Input Calibration Window

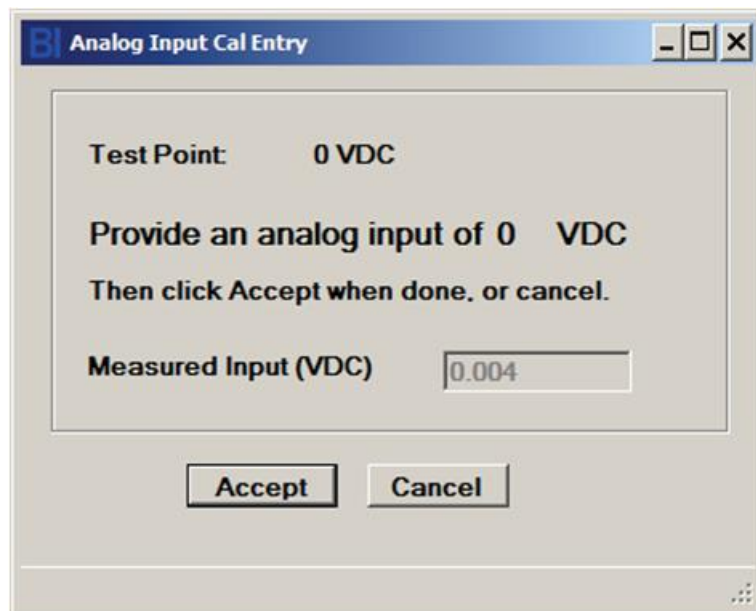

Figure 13-16 Analog Input, Low

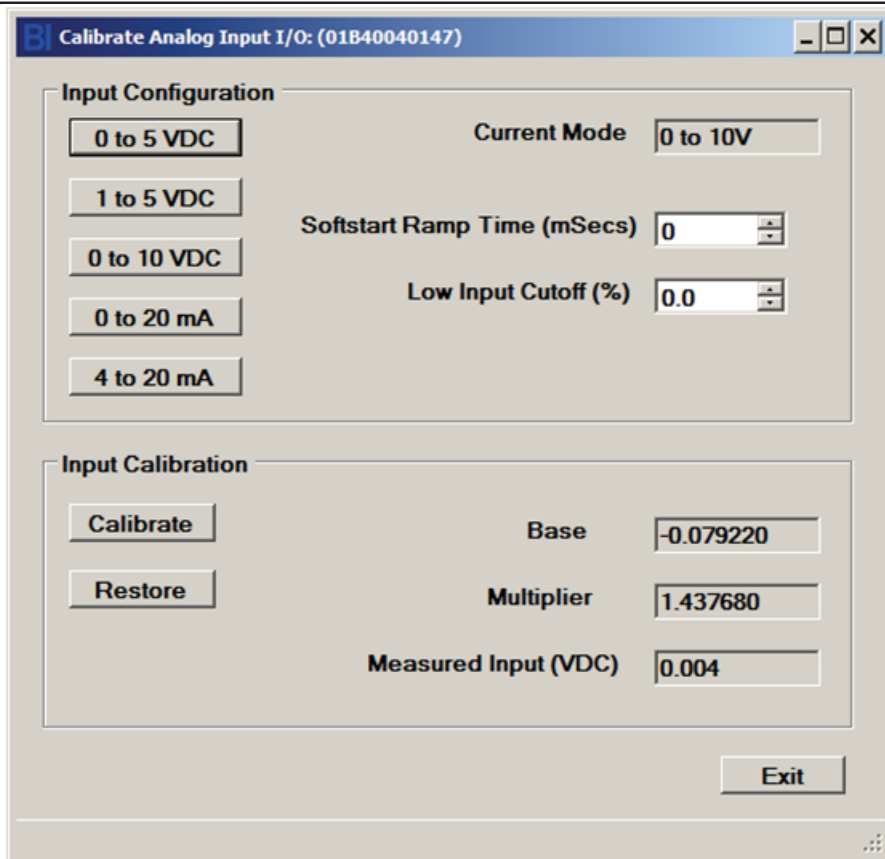

Figure 13-17 Analog Input, High

The user may revert back to the original values of all parameters (when the Analog Input form was last opened) by clicking the restore button.

For SLA Rev B devices, select the mode before performing the calibration. Changing the mode after calibration may invalidate the calibration and require a re-calibration. For GF40 devices, the mode may be changed after calibration, if not changing the mode from voltage to current or vice-versa, without requiring a re-calibration. For GF40 devices, analog input and analog output modes must match.

13.7 RT/Aux Input Calibration

The RT/Aux Input Calibration menu guides the user in calibrating (or “tuning”) the auxiliary input of an RT device (SLA only). The auxiliary input of an RT device is normally connected to the external (“remote”) pressure transducer sensor. But for this calibration operation, the input is connected to variable power supply. This operation adjusts the input sensitivity to the sensor’s range (0 to 5V or 0 to 10V).

The RT/Aux Input Calibration menu allows the user to select the range (0 to 5V or 0 to 10V only), check the adjustment, and calibrate the input.

The user can change the Input Configuration mode by clicking on one of the two range buttons. The current mode is shown in the Current Mode text box.

The user can check the current analog input calibration by providing a voltage with an external source (such as a power supply) to the device’s auxiliary analog input, then viewing the measured “live” level in the Measured Input text box.

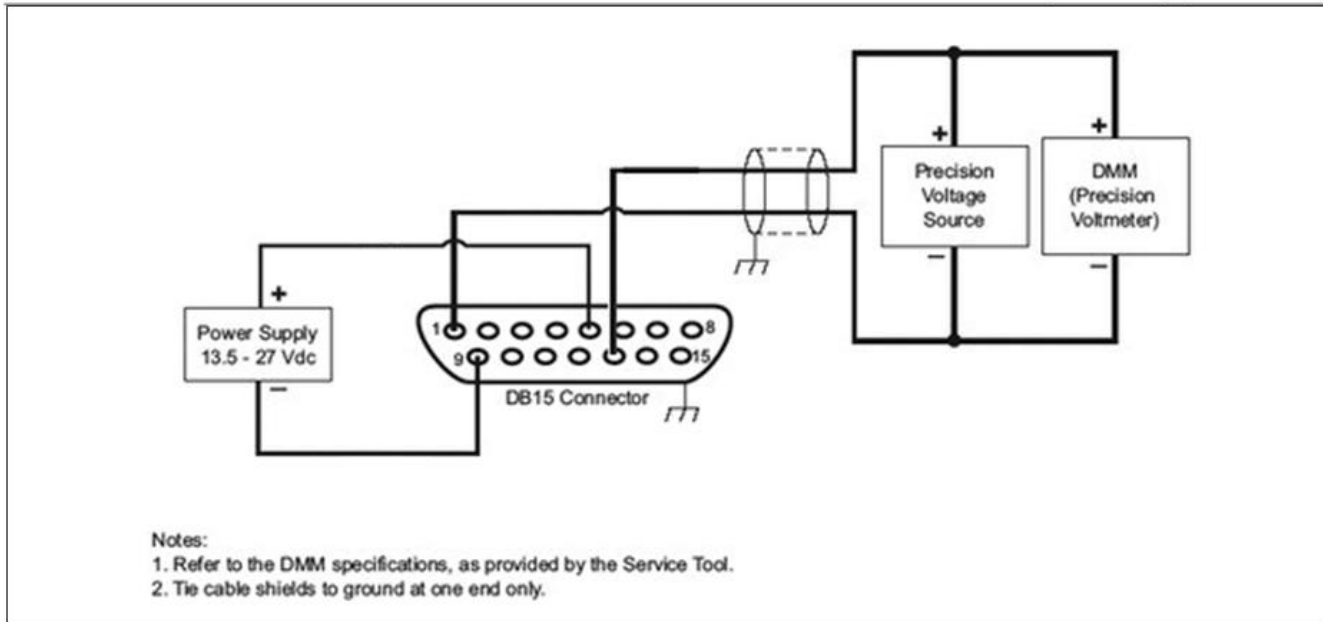

Figure 13-18 Typical Setup for Calibrating the RT Input
(see your device user manual for specific connection information)

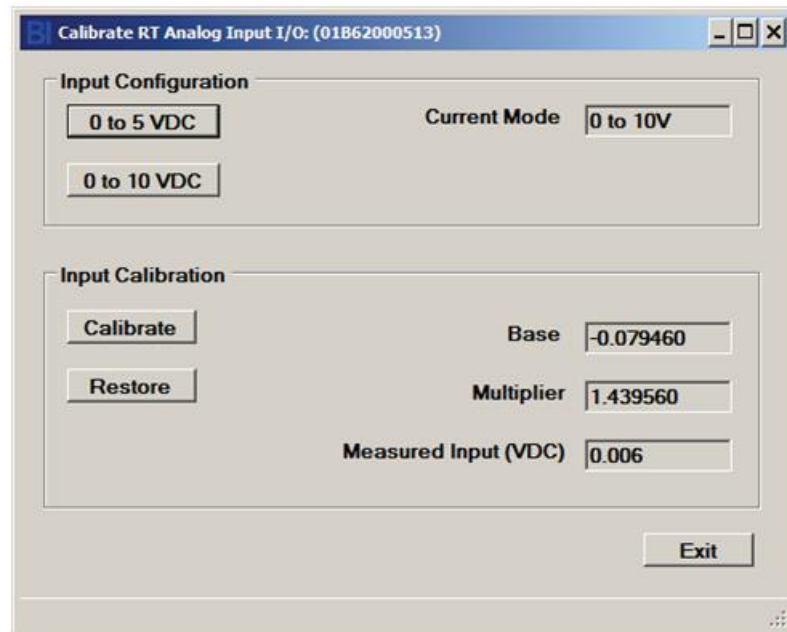

Figure 13-19 RT/Aux Analog Input

To test the device's RT input, simulate the RT voltage using a variable voltage source and verify the Measured Input reading reported in this window.

The user can calibrate the analog input by clicking on the Calibrate button. The calibration process prompts the user to supply external voltages to the device's input at two points (high and low), then performs an interpolation to calculate an offset and factor (or, "base" and "multiplier").

At each of the two points (low and high), supply an external voltage as directed by the software. The live voltage or current is shown in the Measured Input text box. Click Accept when ready.

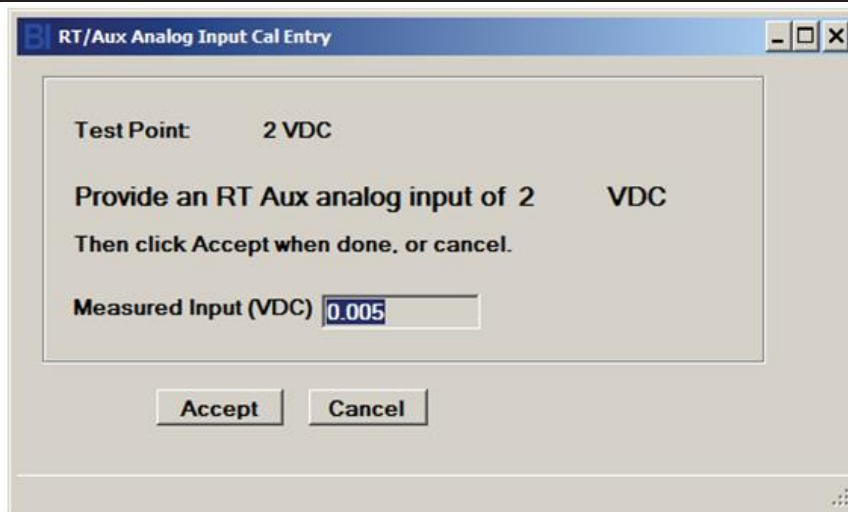

Figure 13-20 RT/Aux Analog Input Cal, Low

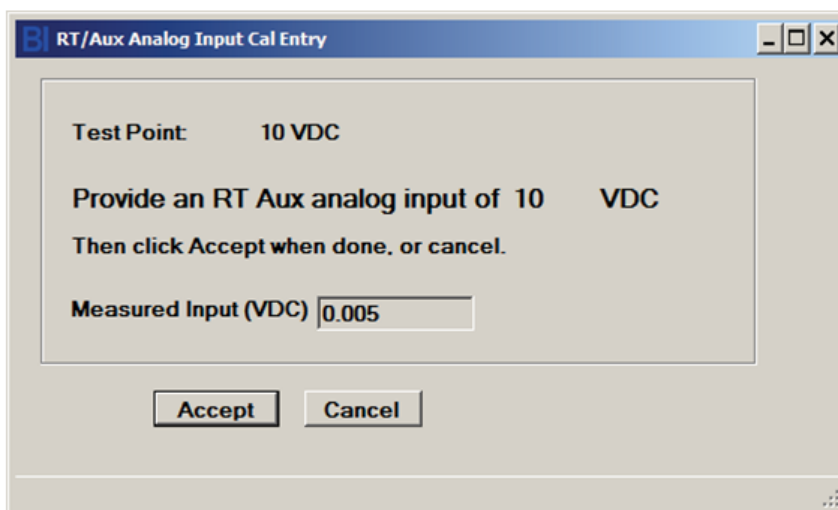

Figure 13-21 RT/Aux Analog Input Cal, High

13.8 Cal Pages

The Cal Pages menu is where the user can select the active calibration page and delete pages. A “page” is a completely configured and calibrated set-up of the device. A page is created at the factory, or via the calibration process. A page is selected from the set of pages (the “calibration data set”) that have previously been created. For pressure controller devices, a page is also called a “pressure application”.

Typically, this menu is of interest only to users who have a device with more than one calibration page stored in the device.

Flow devices and pressure devices each have a separate set of possible pages and thus, different Cal Pages windows. There are separate menu items for flow pages and pressure pages (see Figure 13-22 and Figure 13-23).

MFC and MFM devices have flow cal pages, PC devices have pressure pages, and RT devices can have both types.

13.9 Flow Cal Pages

The Cal Pages window for flow devices is shown in Figure 13-22.

Cal Pages (Flow): (01B62000513)

Surrogate Gas Pages

Surrogate Gas Page

1: 13 (1000 SCCM @ 21°C) Horizontal Base Down

Delete

Full Scale Value 1000.000 SCCM

Gas Name N2

Gas Identifier 13

Reference Temperature 21.1 °C

Process Gas Pages

Process Gas Page

*1: 13 (1000 cc/min @ 21.1 °C HorizontalBaseDown)

Activate

Full Scale Value 1000 cc/min

Delete

Gas Name N2

Gas Identifier 13

Reference Temperature 21.1 °C

Last Calibration Date 6/14/2019 12:00:00 AM

Calibration Due Date 6/14/2020 12:00:00 AM

Exit

Figure 13-22 Cal Pages Window, for Flow Devices

The Surrogate Gas Pages section of this form is where the user can see the surrogate pages created as a product of the calibration process. The average user rarely needs to be concerned with surrogate pages.

To delete a surrogate page, select the page from the drop-down box, and click delete.

***NOTE** Exercise caution if deleting surrogate gas pages.

The Process Gas Pages section of this form is where the user can view and select from the existing set of created calibration pages. To see the complete set of pages present in the device, click on the Process Gas Page drop-down box.

The active page is prefixed with an asterisk in the Process Gas Page drop-down box. To activate a page, select one of the pages from the drop-down box, then click Activate. To view selected parameters of a page, select the page from the drop-down box, and the parameters are shown below the drop-down boxes.

To delete a page, select the page from the drop-down box, and click delete.

***NOTE:** Exercise caution if deleting pages.

To create a new flow page, use the full calibration process ([Section 13.12](#)).

13.10 Pressure Cal Pages

The Cal Pages (or “Application” Pages) window for pressure devices is shown in Figure 13-23.

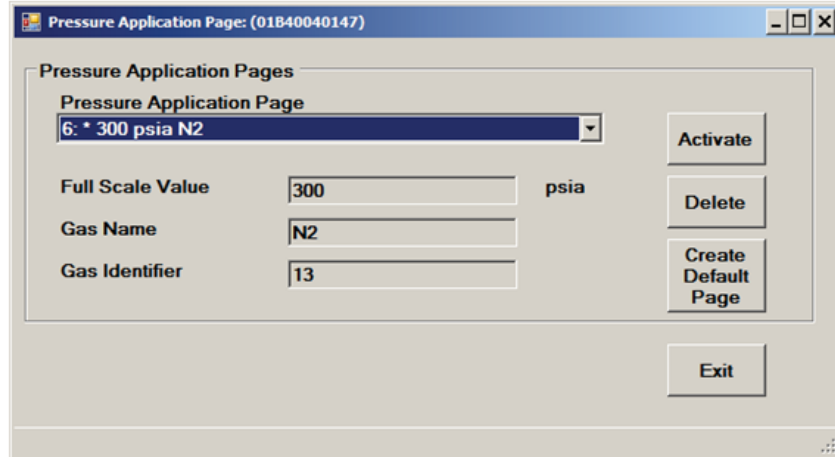

Figure 13-23 Cal Pages Window, for Pressure Devices

The Pressure Application Pages section of this form is where the user can view and select from the set of created pressure calibration pages. To see the complete set of pages present in the device, click on the Pressure Application Page drop-down box.

The active page is prefixed with an asterisk. To activate a page, select one of the pages from the drop-down box, then click Activate. To view selected parameters of a page, select the page from the drop-down box, and the parameters are shown below the drop-down boxes.

To delete a page, select the page from the drop-down box, and click delete.

***NOTE** Exercise caution if deleting pages.

If the user has a license installed, they can create a default page (uncalibrated).

To create a default page, click Create Default Page. A new window appears as shown in Figure 13-24.

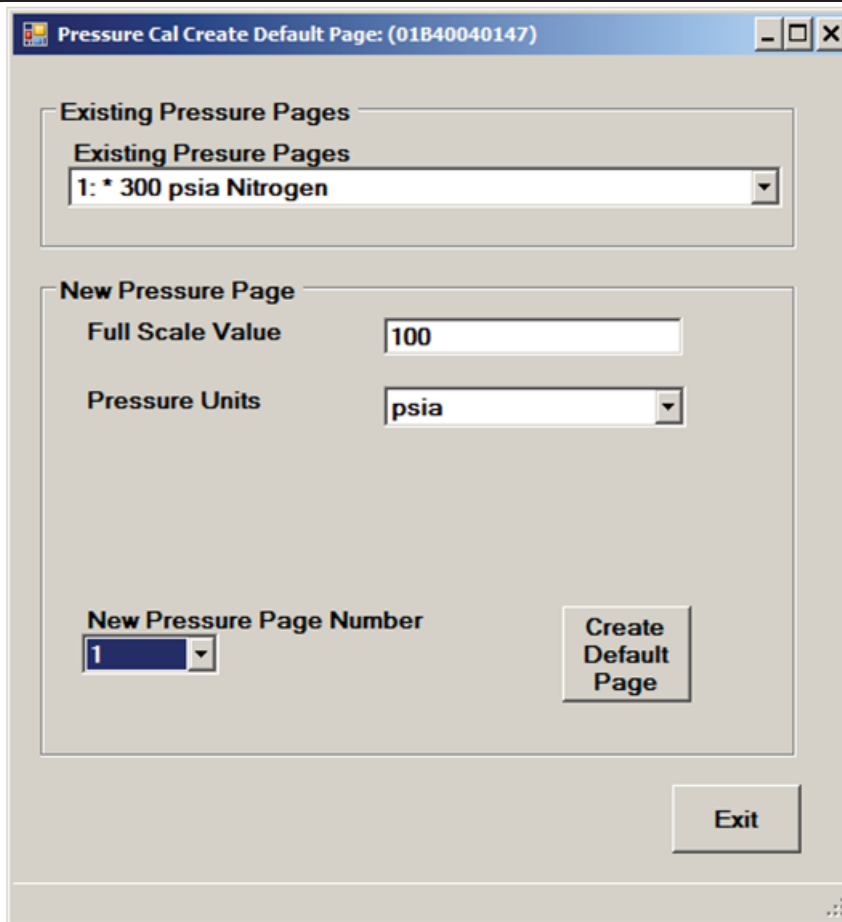

Figure 13-24 Create Default Page Window, for Pressure Devices

In this form, the Existing Pressure Pages section shows the existing pressure calibration pages, the same as in the previous form (but you can't change the active page from here, this is just for viewing purposes).

In the New Pressure Page block, it shows selected parameters that will be used in the new default page. For pressure controller devices, the Full-scale Range here must be \leq the internal transducer range.

Below that is the New Pressure Page Number drop-down box. The user can select a page number for the new page.

To create the new page, click Create Default Page. If the user selected a page number that already exists, the user will be prompted whether they want to overwrite the existing page. Note that the "default page" that is created is not a calibrated page. To create a calibrated page from a previously created surrogate page, see [Section 13.12](#), to create a Customer Page.

Once the new page is created, it will appear in the list of process gas pages.

13.11 Calibration

The Calibration menu is where the user can calibrate their devices for accuracy. The calibration procedure requires a license (see [Section 5.1.2](#)).

Users can calibrate both flow and pressure devices, including RT devices. With supported devices, users can create multiple calibrations, stored in “pages” in the device (see [Section 13.8](#)). The user can then switch between calibrations by selecting pages.

Generally, the software automatically detects the device type and guides the user in the appropriate type of calibration to perform. The processes and windows that appear may be different, depending on the device type and calibration type.

The calibration process typically involves the following steps: setting up a calibration, performing the calibration, validating the calibration, and producing calibration reports.

To perform a calibration, the following conditions are required:

- The device has been configured properly (including the model code).
- The device has been sufficiently warmed up to achieve thermal stability (reference the device operation manual).
- The sensor has been zeroed.
- There is a supply of gas.
- During the calibration process, the device must be in a thermally stable environment. Rapid or significant temperature changes during the calibration process can affect the device’s accuracy.
- See also the device user manual.

Calibrating a meter (MFM) device is very similar to calibrating a Mass Flow Controller. There are a few steps that are slightly different and are described in these instructions where needed. The main difference is to make sure you have a bench setup that can manually control and adjust the flow going through the meter device. See also [Section 11.10](#) for instructions for simulating an MFC device with a meter for calibration purposes.

***NOTE:** Make sure that the model code information is set correctly prior to starting calibration (see [Section 11.5](#)).

13.12 Flow Calibration

Flow calibration is performed for MFC, MFM and RT device types. An example flow calibration window is shown in Figure 13-25.

***NOTE:** GF40 device calibration requires some additional steps. After reading this section, also read [Section 13.13](#) for specific additional instructions. Also, there are some differences for calibrating the GP200 device – see [Section 13.14](#) for details. For these device types, first read this section ([Section 13.12](#)) then read the section for your specific device type.

For most devices, flow calibration is supported when the gas type used for calibration is different than the process gas type. Mixed gas calibration is also supported for SLA Rev B devices.

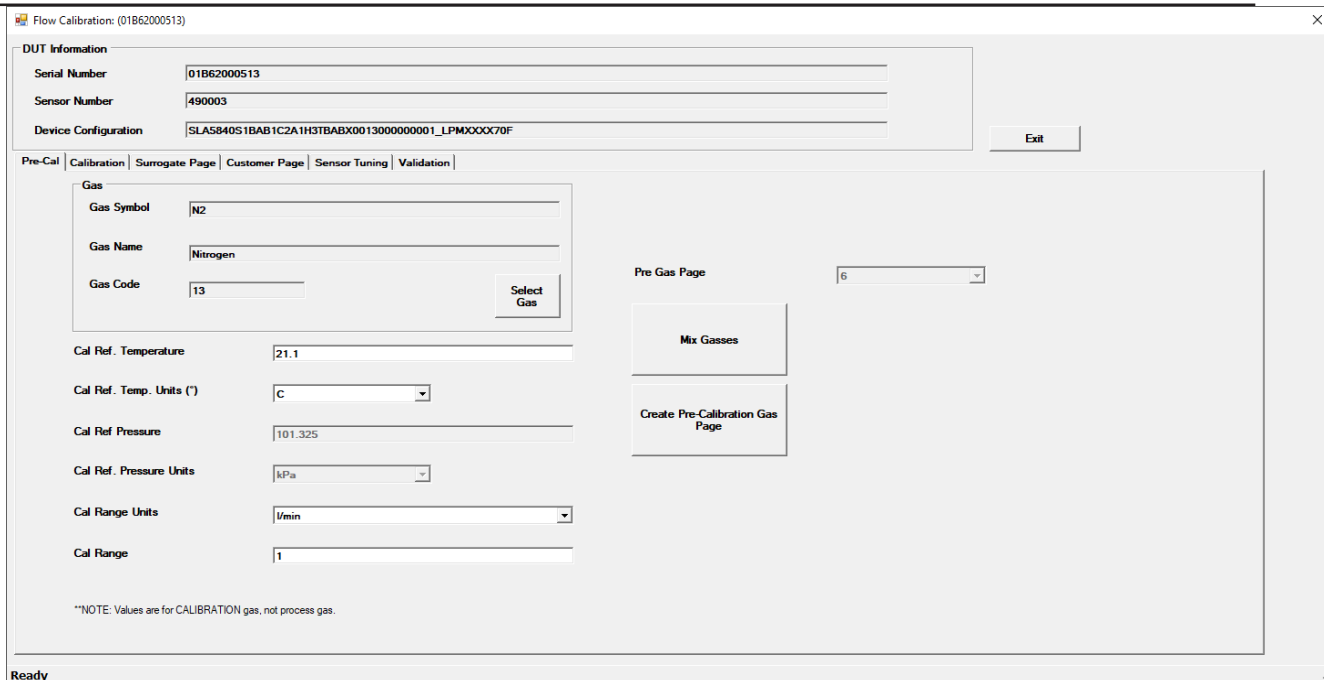

Figure 13-25 Flow Calibration Window

At the top of the window is the DUT Information block. This information is read-only and is for informational purposes only. The Device Configuration text box is the model code.

Below that are five tabs: Pre-Cal, Calibration, Surrogate Page, Customer Page, and Validation (See Figure 13-25). Typically, these tabs are executed in order from left to right. Select each tab by clicking on it.

Pre-Cal Tab: The Pre-Cal tab is performed first. The Pre-Cal tab is shown selected in Figure 13-25. The Pre-Cal tab is not available for the GF1xx or GP200 device.

Below the Pre-Cal tab are a number of user-editable entry fields. When the calibration window is first opened, these user-editable fields are initially populated from the model code (except for reference pressure and units which are set to the last user-entered values).

If the model code was set up correctly prior to entering the calibration window, for most users the data fields will already contain the needed data.

However, in some calibration scenarios, the user may need to change these values. For example, some users may perform calibration with a gas that is different than their process gas (for example, a user may have a process gas of CO₂, but may calibrate with N₂). BEST software can accommodate these scenarios. The Pre-Cal tab information is for the calibration gas, so if the user's calibration gas is different than their process gas, they will need to change this information to their calibration gas.

***NOTE:** The values entered in the Pre-Cal tab are for the calibration gas, not the process gas.

When changing the parameters, the user typically changes the values from top to bottom (i.e., changes the Gas Symbol first, then Gas Range, etc.).

Mixed-Gas Calibration: The user may calibrate with mixed gas in two ways: they may either:

- 1.) do the full calibration with the actual mixed gas, or
- 2.) calibrate with a calibration gas (such as N2 or Air), utilizing a conversion factor for their process mixed gas.

In scenario 1, the user will enter the mixed gas information in the Pre-Cal tab of the calibration window. Click on the Mix Gasses button. In the window that pops up (see Figure 13-26), ensure that the process gas page number is selected. Enter the mixed gas information (this information can be obtained from the Brooks Instrument web site or technical service). Then click Load. Then click exit. The pre-cal tab information will then be updated for using the mixed gas as the calibration gas. Note that the model code text box will be updated with the new gas code for mixed gas.

In scenario 2, the user will enter the calibration gas information in the Pre-Cal tab of the calibration window. Mixed gas information will be entered later in the process.

The user may then click Create Pre-Calibration Gas Page.

***NOTE:** Always double check all user-entered values before clicking the create page button.

The software will warn the user that the create process will overwrite page (page 6 is reserved for the temporary Pre-Cal or “test” page). After a few moments, the pre-cal page will be created. The status bar will indicate success or failure of the page creation process. The process will also make page 6 the active page.

After you have successfully created the pre-cal page, you can proceed to the next tab, by clicking on the Calibration tab.

Calibration Tab: The Calibration tab is shown selected in Figure 13-26.

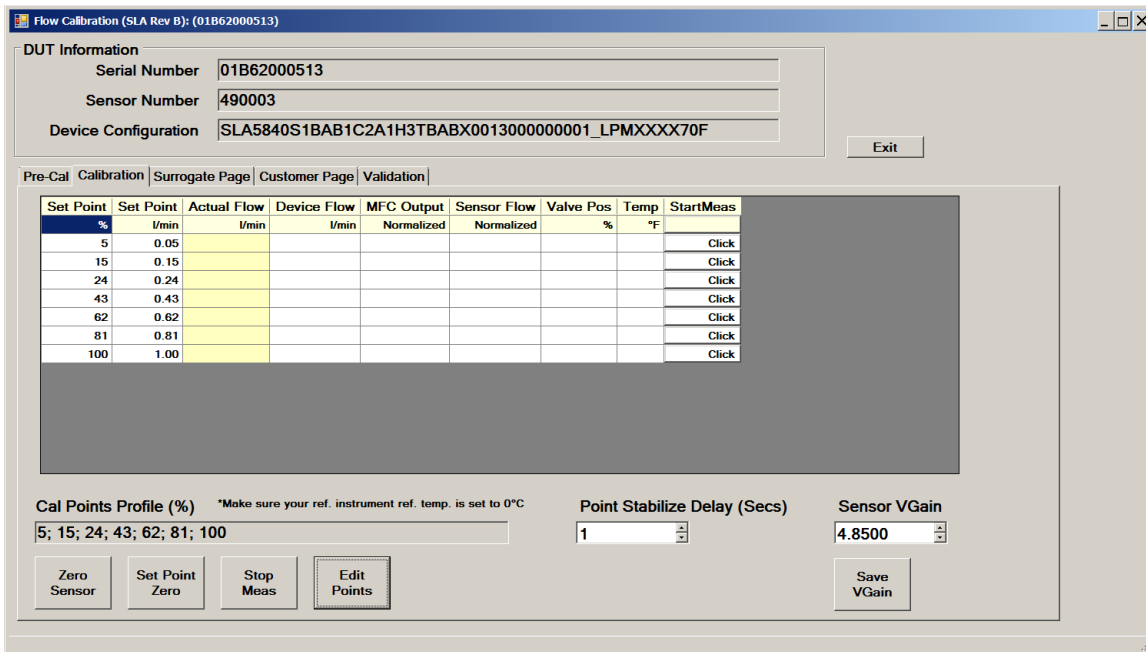

Figure 13-26 Flow Calibration, Calibration Tab

The Calibration tab performs a calibration using the temporary Pre-Cal page (page 6) as a starting point. The Calibration tab is performed after the Pre-Cal page is created. If the device has no Pre-Cal page (page 6), this tab’s calibration cannot be performed and the tab controls will be disabled.

The Calibration tab is not available for the GF1xx or GP200 device.

The user will use an external reference instrument to measure flow values and manually enter them into the calibration grid.

***NOTE:** Before entering any measured data, ensure that your reference instrument's reference temperature is set to the value shown on the Calibration tab, and that the instrument's factor is set appropriately for the calibration gas. Also, you should zero your instrument with no flow, if necessary.

The Zero Set Point button changes the device set point to 0% (useful if the set point list does not contain 0%) and stops the live measurements.

The VGain (where supported) sets the approximate full-scale range. To check the value, click the StartMeas Button for 100% set point. Note the flow value shown by the external flow meter. If it is approximately at the nominal full-scale range, no adjustment is needed. If it is significantly different from the nominal full-scale value, an adjustment may be necessary. To adjust, change the value in the Sensor VGain numeric up/down control. To increase flow, decrease the gain value or vice-versa. You must click Save VGain to set the gain in the device. You may need to repeat this process until the full-scale flow is near the desired range, as it is a trial-and-error adjustment. The VGAIN adjustment is optional. If it is adjusted, it should be done before starting the grid measurements. (Vgain adjustment is not supported for some device types.)

The Point Stabilize Delay value determines how much time delay occurs after clicking a set point button before the user may enter a flow value. This is to help prevent the user from entering a flow value before the flow has stabilized after changing a set point. The delay for the Calibration tab is always the same value as for the validation tab (see Validation Tab section below).

The grid in the center of the Calibration tab is the calibration grid. Each row of this grid represents a set point. Each column represents a measurement at the set point. A number of set points will be measured and characterized to provide a correction for accuracy.

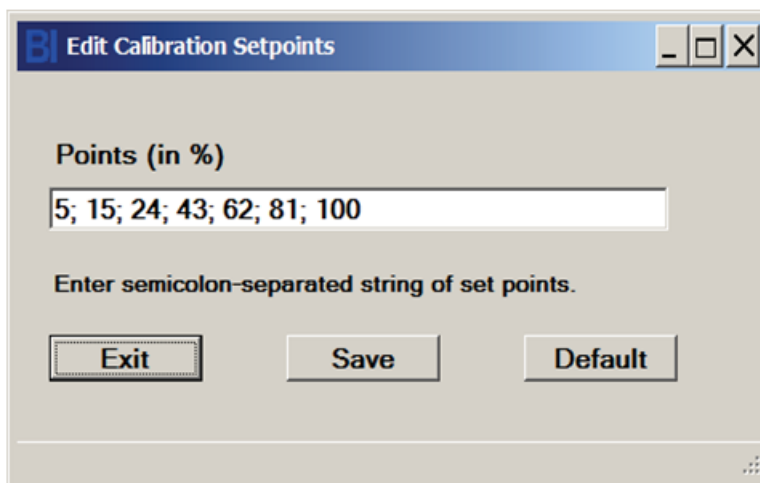

Figure 13-27 Edit Setpoints Window

The two set point columns represent the set point values in percentage (of full-scale) and absolute flow units. The number and values of the set points are user-configurable.

To change the set points, click on the Edit Points button. The Edit Setpoints window appears, as shown in Figure 13-27. For GF40 devices, the setpoints cannot be changed from their default.

Type in or edit a semicolon-separated list of set point percentages. Rules for the set point list are as follows:

- Must be a semi-colon-separated list.
- Number of points must be between 2 and 12.
- All fields must be a numeric integer or floating point.
- All numbers must be between 0 and 100.
- List may not contain duplicate numbers (duplicate numbers are allowed on the validation tab).
- Numbers must be incremental, left to right (non-incremental numbers are allowed on the on the validation tab).

To set the list to its default set, click Default.

When done, click Save, then Exit. The calibration grid now contains the new set of set points.

The first row of the grid contains the titles of the columns. The second row contains the units for each column. The temperature units come from the Pre-Cal tab.

The Zero Sensor button performs the same function as the Calibration-

>Zero Sensor menu item ([Section 13.2](#)). The sensor should be zeroed prior to starting the calibration on the Calibration tab.

The calibration of a setpoint is started by clicking on a Click button in one of the rows under the StartMeas Column. Clicking on one of these buttons starts a live measurement at the set point of the clicked row. The software will set the device's set point to the value in the set point column, and then continually read the device's output including flow, temperature, and valve position.

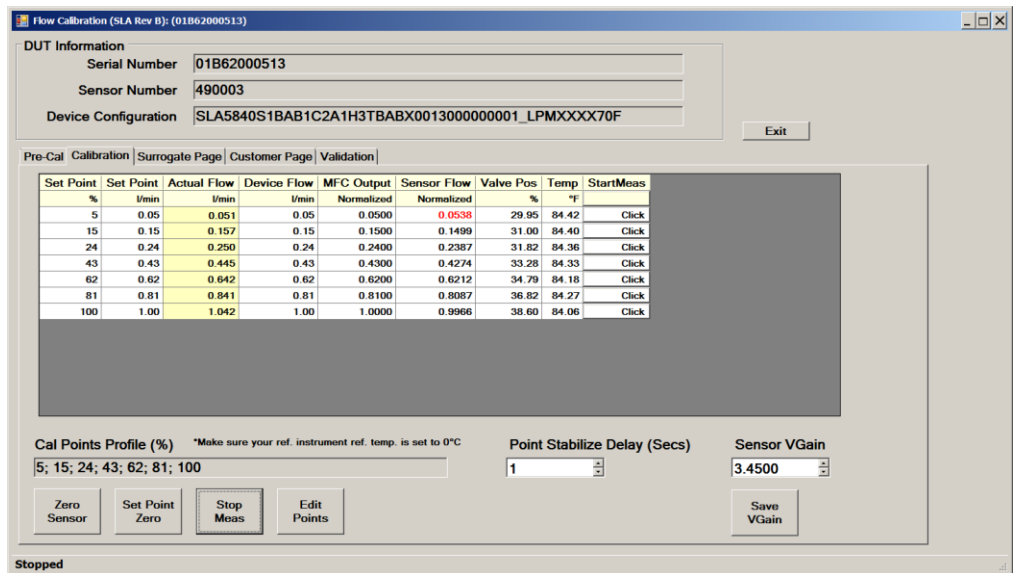

Figure 13-28 Calibration Tab, Filled Out

When performing this calibration with a meter type device, a pop-up window will appear, prompting the user to manually adjust the flow through the device (See Figure 13-29). Since meter devices do not have a valve, the user must adjust the flow manually in their system. Also, the Valve Position column will not show valid data for a meter device, of course.

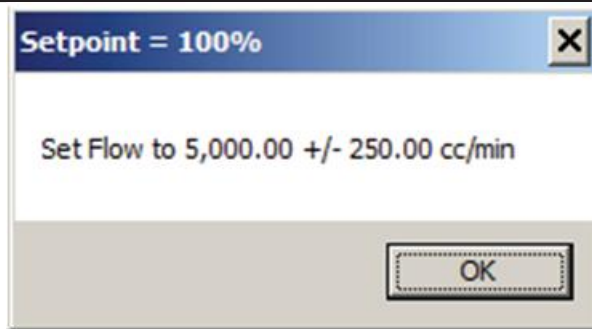

Figure 13-29 Flow Cal, Meter Setpoint Prompt

An external flow measuring instrument is required. The user will read the flow measurement from the external instrument and manually type it into the Actual Flow column.

*NOTE: If the actual flow is not within 5% of the set point, the MFC output columns will turn red as a warning. When calibrating meters, take care to accurately manually adjust the flow rate (until the columns are no longer red).

To go to another row (another set point), click a Click button in one of the other rows under the StartMeas Column. All rows must be filled out to continue the calibration beyond this tab. Set points can be completed in any order.

To stop live measurements, click the Stop Meas button or click on another tab.

When you have filled out the grid info for all set point rows, you should click Stop Meas.

Then you can proceed to the next tab, by clicking on the Surrogate Page tab.

Surrogate Page Tab: The Surrogate Page tab is shown in Figure 13-30.

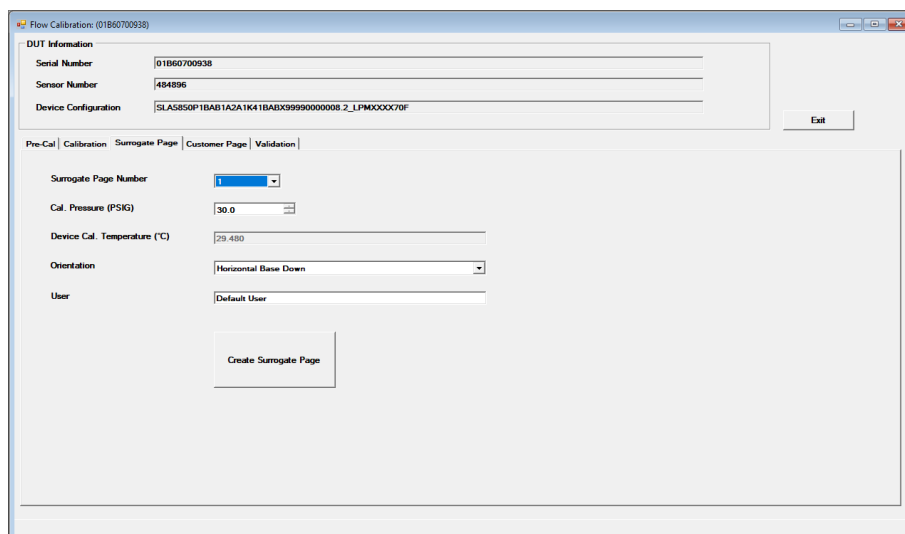

Figure 13-30 Flow Calibration, Surrogate Page Tab

The surrogate page tab process uses the pre-cal page and the calibration data from the Calibration Tab to create another background page called the surrogate page. Once the surrogate page is created, multiple calibrations can be easily generated from this surrogate page without having to perform the whole calibration process again.

The Surrogate Page tab is not available for the GP200 device.

Upon clicking on the Surrogate Page tab, if the PreCal page 6 does not exist in the device, the tab's controls will be disabled. Then go back to the pre-cal tab to create a test page (page 6).

After clicking on the Surrogate Page tab, it will show the device temperature, a default calibration pressure, the device's current orientation, and the current user logged on to the computer. The user can change these parameters if desired – this info will be stored into the device.

The user will select a surrogate page number. For most applications, choose page 1. For GF40 devices, page 1 is selected and cannot be changed. For Biotech devices, if the cal gas is N2 or Air choose surrogate page 1, or if the cal gas is CO2, choose surrogate page 2.

To create the surrogate page, click the Create Surrogate Page button.

When finished, click on the Customer Page tab.

Customer Page Tab: The Customer Page tab is shown selected in Figure 13-31.

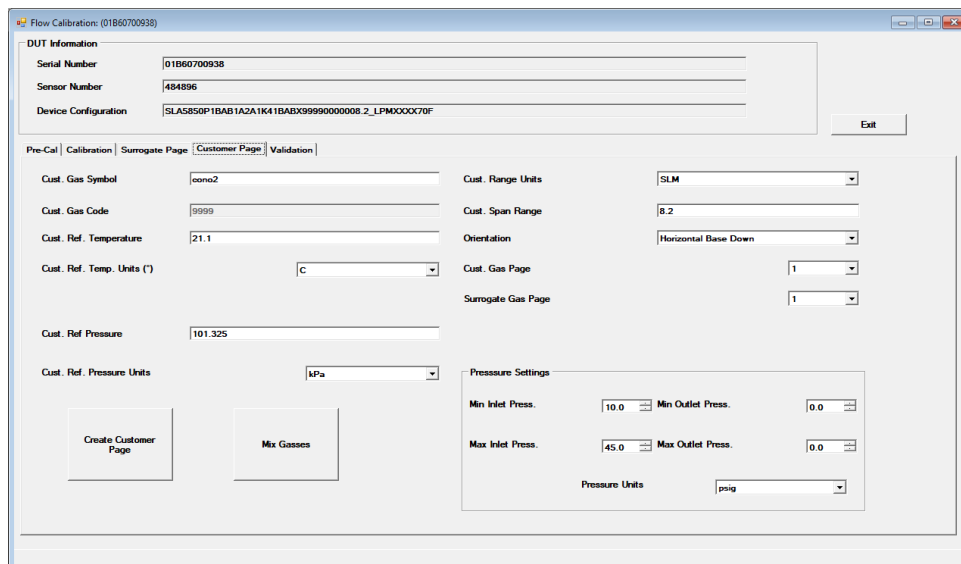

Figure 13-31 Flow Calibration, Customer Tab

The Customer Page tab creates calibration page in the device (based on the Surrogate Page created in the Surrogate Page tab) as a starting point. Multiple custom calibration pages can be created from the same surrogate page without having to repeat the full calibration. Pages may be created for a different gas than was used for the calibration.

The Customer Page tab is performed after the Surrogate tab page is performed. If the device has no surrogate page, this tab's calibration cannot be performed and the tab will be disabled. When the Customer Page tab is clicked, it is initially populated with values from the current device page, or if no device page exists, from the surrogate page.

Below the Customer tab are a number of user-editable entry fields. When the Customer tab is selected, these user-editable fields are populated with the values from the device's surrogate page (except for reference pressure and units which are set to the last user-entered values).

The user may use the existing data in the fields or, in some calibration scenarios, the user may need to change these values. For example, some users may perform calibration with a gas that is different than their process gas (for example, a user may have a process gas of CO2, but may calibrate with N2). The customer page is where the user enters the process gas (not the calibration gas) and its associated parameters.

When changing the parameters, the user typically changes the values from top to bottom (i.e., change the Gas Symbol first, then Reference Temperature, etc.).

***NOTE:** Initially, the parameter values may or may not initially match the parameters from the model code. The user must make sure to enter the values that will be used for the process gas prior to creating the customer page (before clicking the Create Customer Page button). In most scenarios, the data values will be changed to match the model code, if necessary.

As the user changes these values (and moves the cursor off a text box), the range value is automatically re-calculated, taking into account the other customer parameters in order to convert the range to its equivalent of the device. Finally, the user may manually change the range explicitly to the desired value.

The user will select the Cust. Gas Page from the drop-down list for the page number where they want to store the new calibration.

The user will select a surrogate page number (1 to 6 for most device types) from which the customer page (process page) will be generated. For most applications, choose page 1. For GF40 devices, page 1 is selected and cannot be changed. For Biotech devices, the user may need to choose page 1 or 2.

Table 13-1 Biotech Gas Page Restrictions

Output Enhancements Model Code Option	Process Page #	Gas	Surrogate Page#
Normal (Code S or T)	1	N2	1
Normal (Code S or T)	2	CO2	1
Normal (Code S or T)	3	Air	1
Normal (Code S or T)	4	O2	1
Secondary (Code U or V)	1	N2	1
Secondary (Code U or V)	2	CO2	2
Secondary (Code U or V)	3	Air	1
Secondary (Code U or V)	4	O2	1

Mixed Gases: If the user's process gas consists of a mix of gasses, the user may use BEST's mixed gas set up. The user will need to obtain mixed gas parameter data on their mixture (contact Brooks Instrument).

(Mixed gas is supported only for the SLA Rev B device).

Cust. Gas Page*	1
Mix Gas Code	9991
Sensor Factor	0.83429998
Viscosity	0.0108899996
Mol. Weight	13.0900002
Gamma	1.3789999
Gas Mixture Name	CH3Cl3Si@7.5% H2@92.5%

Set Page # to Customer Page, not Test Page.

Exit Load

Figure 13-32 Mixed Gas Data Entry Form

Enter the data, including a custom name for gas mixture. Click Load and then Exit. The user is returned to the calibration window, Customer Page tab. Note the new value of the Cust. Gas Symbol and Cust. Gas Code. 999n is the code for mixed gas where n is the process page number (code 9999 is supported for heritage devices). The Cust Span Range may also change. Note that the model code text box will be updated with the new gas code for mixed gas.

DUT Information	
Serial Number	01B62000513
Sensor Number	490003
Device Configuration	SLA5840S1BAB1C2A1H3TBABX99990001_LPMXXX70F

Pre-Cal | Calibration | Surrogate Page | **Customer Page** | Validation

Cust. Gas Symbol	5%Cl2 95N2	Cust. Range Units	l/min
Cust. Gas Code	9999	Cust. Span Range*	0.993
Cust. Ref. Temperature	21.1	Orientation	Horizontal Base Down
Cust. Ref. Temp. Units (°)	C	Cust. Gas Page	1
Cust. Ref. Pressure	101.325		
Cust. Ref. Pressure Units	kPa		

Create Customer Page Mix Gases

Figure 13-33 Flow Cal, Mixed Gas, Customer Tab

Always be sure to double check all the entered data before clicking the Create Customer Page button. When all the data parameters are selected, the user is ready to click the Create Customer Page button. After the user confirms, the page will be created and activated.

The user may create multiple pages.

Sensor Tuning Tab:

The Sensor Tuning allows for Upstep and Downstep sensor tuning (for SLA Flow controller products only).

To run the Sensor Tuning operation, follow the step-by-step instructions on the screen (in red). The user may select Upstep, Downstep, or both. Click the Tune button to start.

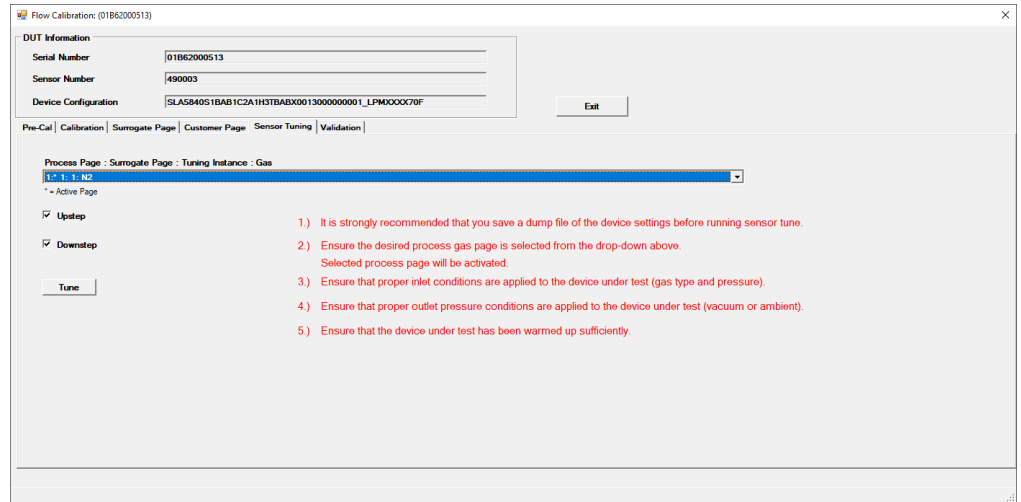

Figure 13-34 Sensor Tuning

Validation Tab: The Validation tab is shown selected in Figure 13-35.

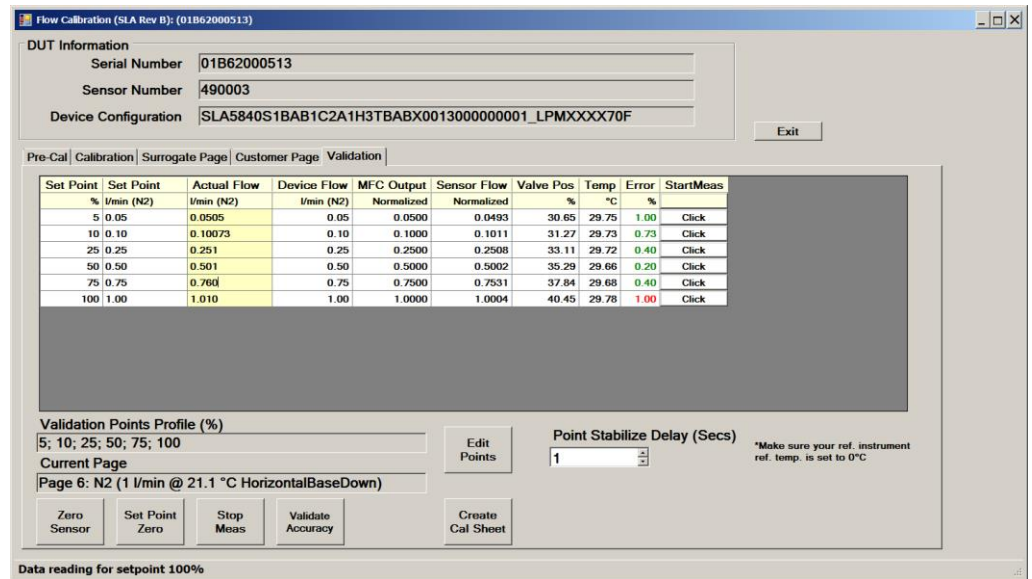

Figure 13-35 Flow Calibration, Validation Page

If the calibration gas and customer gas are the same gas, the validation is performed using the process gas. However, if the calibration gas and customer gas are different gasses, the validation is performed using the calibration gas.

The Validation tab performs a validation of a customer page's calibration. The page verified is the current active page. It is assumed that the current page is the process gas page. The Customer page was created in the Customer Page tab. The Validation tab is performed after the Customer page is created. If the device has no customer page, this tab's validation cannot be performed and the whole tab will be disabled.

The grid in the center of the Calibration tab is the validation grid. Like the calibration grid, each row of the validation grid represents a set point. Each column represents a measurement at a set point. A number of set points will be measured and checked for accuracy.

The set point columns represent the set point values in percentage and absolute flow units. The number and values of the set points are user-configurable. The set of validation points does not need to match the set of calibration points. To change the set points, click on the Edit Points button. The Edit Setpoints window appears, as shown in Figure 13-27, the same way as for calibration set point selection.

The Point Stabilize Delay value determines how much time delay occurs after clicking a set point button before the user may enter a flow value. This is to prevent the user from entering a flow value before the device has stabilized (in terms of flow control) after changing a set point. The delay for the Validation tab is always the same value as for the Calibration tab (see Calibration Tab section above).

The first row of the grid contains the titles of the columns. The second row contains the units for each column.

Like the calibration tab, the validation for a set point is started by clicking on a Click button in one of the rows under the StartMeas Column. The software will set the device's set point to the value in the set point column, and then continually read the device's output including flow, temperature, and valve position. See Figure 13-35.

***NOTE:** When performing this validation with a meter device (MFM), a pop-up window will appear, the same one that appears for the Calibration tab, prompting the user to manually adjust the flow through the device (See Figure 13-29). Since meter devices do not have a valve, the user must adjust the flow manually in their system. Also, the Valve Position column will not show a valid value for meter devices.

***NOTE:** If the actual flow is not within 5% of the set point, the MFC output columns will turn red as a warning. When calibrating meters, take care to accurately manually adjust the flow rate (until the columns are no longer red).

***NOTE:** The accuracy calculation is the comparison of the expected flow and external actual measurement. The pass/fail criteria (red or green) is based on the percentage of full-scale for all points.

Like the calibration tab, in the validation tab the user must enter the actual flow into the Actual Flow column, the column with a yellow background. An external flow measuring instrument is required. The user will read the flow measurement from the external instrument and manually type it into the Actual Flow column.

***NOTE:** Before entering any measured data, ensure that your reference instrument's reference temperature is set to the value shown on the Validation tab, and that the instrument's factor is set appropriately for the calibration gas.

To go to another row (another set point), click a Click button in one of the other rows under the StartMeas Column. All rows must be filled out with valid numeric data to complete the validation and create a certification sheet (see Section "Create Cert" below). Set points can be completed in any order.

Once a user types in an actual flow value, the error percentage is automatically calculated and updated for the current row (current setpoint).

Clicking the Validate Accuracy button stops live measurements and recalculates the accuracy for all set points (all rows). The accuracy calculation compares the target set point/flow rate to the (manually entered) external meter value.

At any time, to stop live readings, click the Stop Meas button.

The Zero Set Point button stops live measurement and changes the device set point to 0% (useful if the set point list does not contain 0%).

When you have filled out the grid info for all set point rows, you should click Stop Meas. Then, if desired, you can proceed to create a cal sheet report (see next section).

***NOTE:** If your calibration gas is different than your process gas, see also the sub section below “Calibrating when the calibration gas and process gas are different.”

Create Cal Sheet: Once the validation is completed, the user can print out a calibration sheet. This is a report showing the validation results data and some custom user information.

Click the Create Cal Sheet button. A window will open showing a pre-selected set of configuration data. It also allows the user to choose a set of custom configuration data items that will appear on the report, in addition to the calibration data. The user may select, edit, and save the set of custom configuration data for the report (See Figure 13-36).

The fields with a white background are initialized with values from the device or software. Fields with a yellow background are initialized with values from a user profile. A user profile is a set of user-selected values that are stored so that the user does not have to repeatedly type in the same values. The user saves a set of values in a profile, creates a profile, and selects a profile. The fields with a gray background cannot be changed by the user. The user may also select the image that appears on the footer of the report. The user may choose the default or may provide their own logo.

The user may also select the number of decimal places that appear in the tabular data on the report, via the Decimal Places box.

Figure 13-36 Flow Cal, Cert Sheet Preview Page

After this, click Generate Report and a preview of the report information will be displayed.

Flow Calibration Report Display

Calibration Data Sheet

Device Information	Calibration Information	Mechanical Information
Serial Number 01B62000513	Calibration Inlet Pressure X	Valve Type Normally Closed
Model Number SLA5840S1BAB1C2A1	Calibration Outlet Pressure XX	Valve Seat Material Viton
Customer Brooks Hatfield	Gas Conversion Factor 1.0000	O-ring/Seal Material Viton
Customer Fluid N2	Calibration Fluid N2	Mounting Attitude Horizontal Base Down
Full Scale Flow 1 l/min	Calibration Software/Revision 5.1.2.5	Power Supply 24 Vdc
Reference Temp/Pressure 21.1 °C / 101.325 kPa	Calibration Location Hatfield	Reference Number 629604001
Customer Inlet Pressure 30 PSIG	Calibration System ID System 1	Alternate ID 18
Customer Outlet Pressure 0 P SIG	Calibrator Miller	Tag Number 186817/03
Input RS-485 4 to 20 mA	Calibration Date/Time 6/20/2018 1:28:26 PM	Calibration Notes -Test 1
Output RS-485 4 to 20 mA	Calibration Procedure 123	
Customer Part Number	Calibration # 1 of 1	

Calibration Check Data Setpoint vs. Error (% Rate) 0.9% Rate, 0.18% F.S. < 20%

Setpoint%	Output%	Flow (l/min)	Error (%Rate)
5.00	5.000	0.05	1.000
10.00	9.999	0.10	0.730
25.00	25.000	0.25	0.400
50.00	50.001	0.50	0.200
75.00	75.000	0.78	0.400
100.00	100.000	1.01	1.000

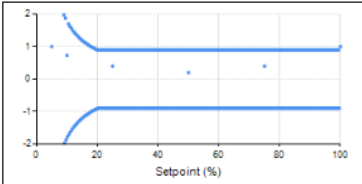

Brooks Instrument 407 West Vine Street P.O. Box 303 Hatfield, PA 19440-0903 USA T: 215-362-3000 F: 215-362-3745 http://www.brooksinstrument.com/	Brooks Instrument Eindhovenstraat 53 3952 HW Voornendaal The Netherlands T: +31-318-549300 F: +31-318-549309	Brooks Instrument Berezny 72-100 8000 Zvezdaselshvar Hungary T: +36(22) 539 600 F: +36(22) 539 659	Brooks Instrument FTW Japan Ltd. 1-4-1 Kasasaka Koto-Ku Tokyo, 136-0073 Japan T: +81 03 5633 7105 F: +81 03 5633 7101
---	---	---	--

Approved by: _____
This report shall not be reproduced, except in full, without written approval from Brooks Instrument. Ref: OPI-004-1
 Page 1 of 1

Print

Save

Close

Figure 13-37 Flow Cal, Cert Sheet

From there, the user may view, print or save the report to file.

Calibrating when the calibration gas and process gas are different: In some scenarios, the user may need to calibrate for their process gas, but may not be able to use their actual process gas for calibration (for example when the process gas is expensive or hazardous). In this case, BEST supports the calibration/validation using a calibration gas that is a different gas than the process gas (For example, the process gas is CO2, but the calibration gas is N2). In BEST, the validation may be performed using either the calibration gas or the process gas. However, for the GP200 device, the validation can only be performed with the process gas.

For this scenario, the calibration process is similar, but there are a few differences. The differences are in the Validation process in the Validation tab).

***NOTE:** When first starting the calibration process, make sure the model code is set correctly before starting the calibration. The model code must be set to the process gas settings, not the calibration gas settings.

When the user creates the process page (in the Customer Page tab), they will select the process gas. But then, the validation may be performed with either the process gas or the calibration gas. After the user creates the process page with a gas that is different from the calibration gas, and then clicks on the Validation tab, the grid will have two additional columns.

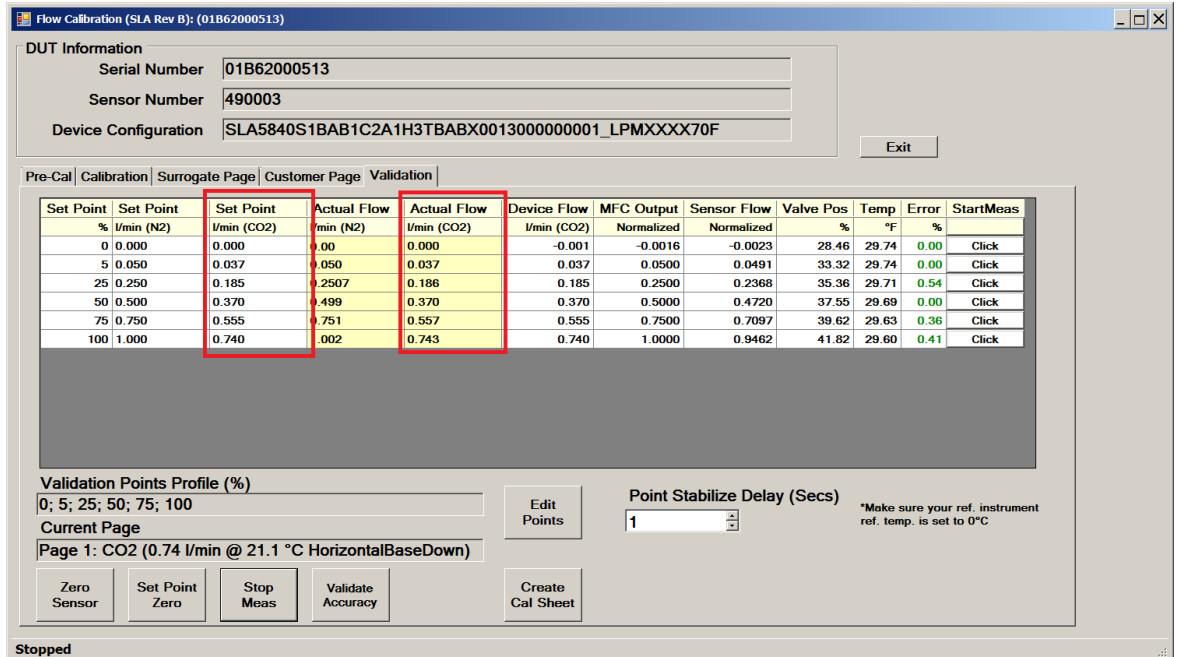

Figure 13-38 Validation Tab when cal gas and process gas are different

Now, there are two columns for setpoint in flow units, one in the calibration gas equivalent, and one in the process gas equivalent (the gas symbols are shown for each column in the header row). Similarly, there are two columns for actual flow in flow units, one in the calibration gas equivalent, and one in the process gas equivalent (the gas symbols are shown for each column in the header row).

Validation is performed with a process that is similar to the process if the calibration gas and process gas were the same. The difference is that the user will enter the measured flow in either one of the actual flow columns (with a yellow background), depending on which gas they are using to validate. In our example, if they are validating with CO2 (process gas), they will enter their values in the Actual Flow column labeled for CO2. Alternatively, if they are validating with N2 (calibration gas), they will enter their values in the Actual Flow column labeled for N2. After the user enters the value, the equivalent flow value for the other Actual Flow column will be calculated automatically.

The error/accuracy calculation will always be based on the actual flow from the process gas column. Likewise, the data for the cal sheet will always be based on the actual flow from the process gas column.

13.13 GF40 Device Flow Calibration

Flow calibration for GF40 devices is similar to flow calibration as described in [Section 13.12](#), but with the differences listed in this section ([Section 13.13](#)). If you haven't already done so, read [Section 13.12](#) before reading this section.

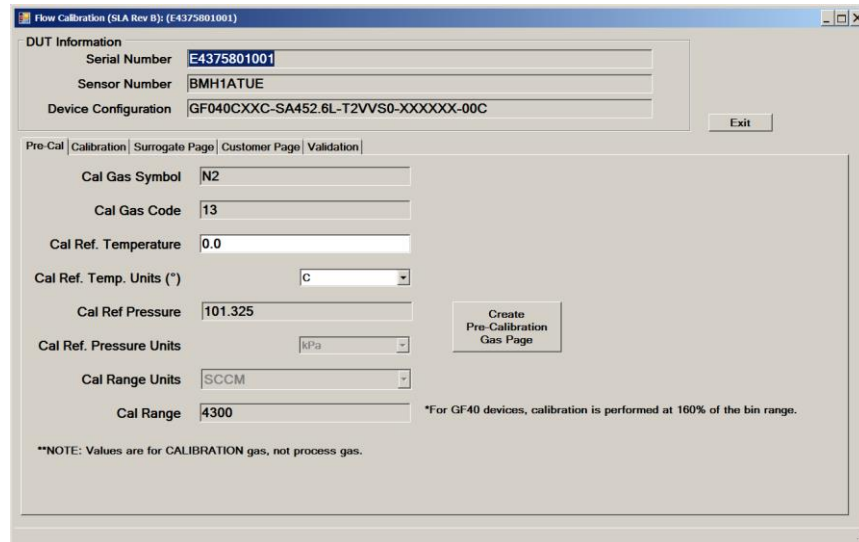

Figure 13-39 Calibration, Pre-Cal Tab, GF40

Pre-Cal Tab: For GF40 devices, Pre-Cal may be done at around 160% of the bin range for some bins, depending on the range. The gas is always N2, and the flow units are always SCCM. The bin and range are shown in the Device Configuration text box as part of the model code.

***NOTE:** For GF40 devices, calibration is always performed with nitrogen gas, even if the process gas is not nitrogen.

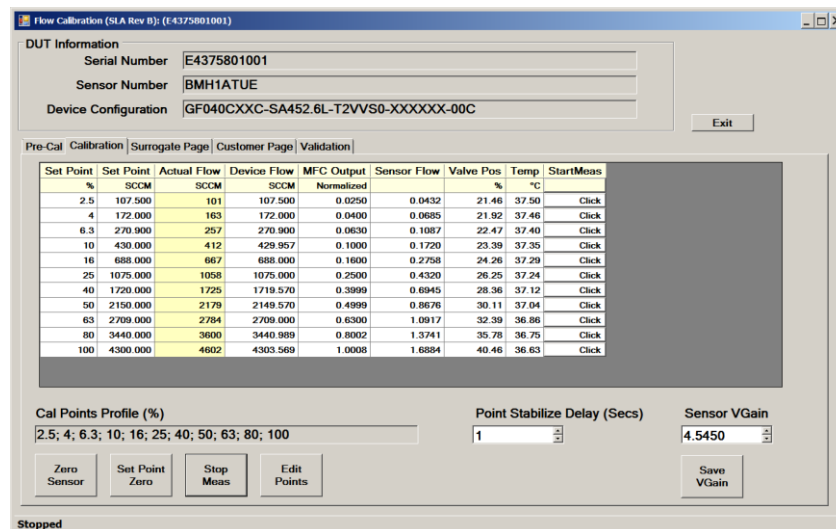

Figure 13-40 Calibration, Calibration Tab, GF40

Calibration Tab: The Calibration tab operation is the same as in [Section 13.12](#), except that the calibration set points profile is not editable.

Surrogate Page Tab: The Surrogate Page tab operation is the same as in [Section 13.12](#).

Customer Page Tab: The Customer Page tab is created with the user's desired final flow range, units, and gas, the same as in [Section 13.12](#).

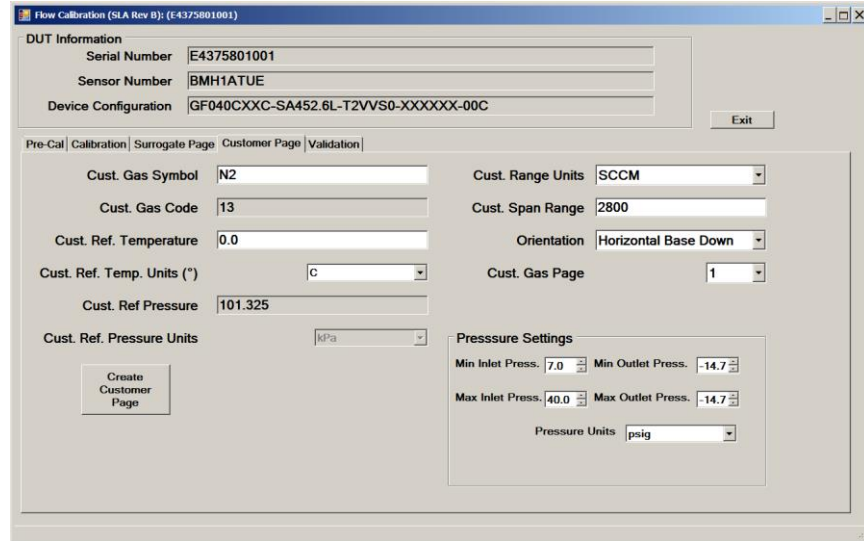

Figure 13-41 Calibration, Customer Page Tab, GF40

Validation Page: The validation step has an additional step compared to [Section 13.12](#). Notice that there is an additional button at the bottom of the page: Create Validation Page.

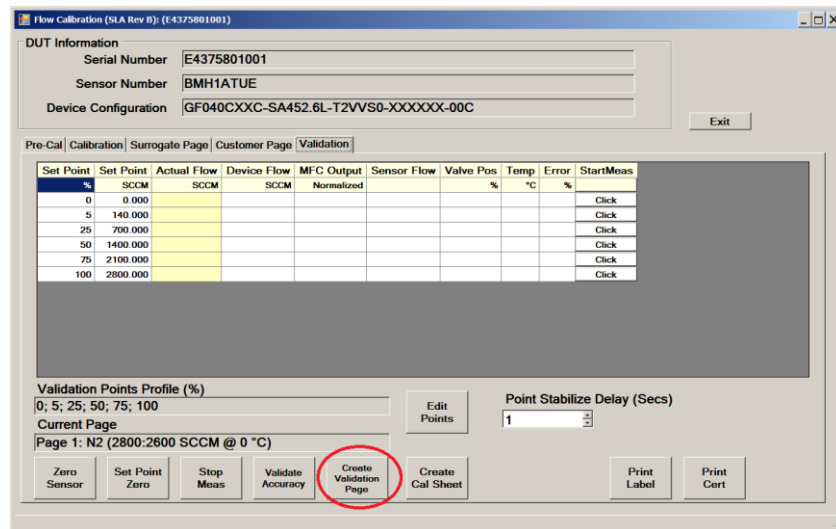

Figure 13-42 Calibration, Create Validation Page, GF40

Click the Create Validation Page button. This will create an additional page in the device called a "Validation page". This is the page that will be used to validate the device's calibration. This page will be set up to measure the flow range at set points up to the 100% of the bin range at the Nitrogen equivalent flow.

***NOTE:** For GF40 devices, validation step is always performed with nitrogen, even if the process gas is not nitrogen. Thus, it is required to create the validation page. This validation page will be created at 100% of the bin range, regardless of the customer page range.

After you click the Create Validation button, choose a blank page number (2 by default) – be careful not to choose the customer page you just created in the previous step. After the new validation page is created, that page will be activated, and that is the page on which the next step of validation will be performed. The validation grid may be re-oriented to match the new scale of the new validation page. Notice in the Current page text box, that page 2 is now activated and ready for validation.

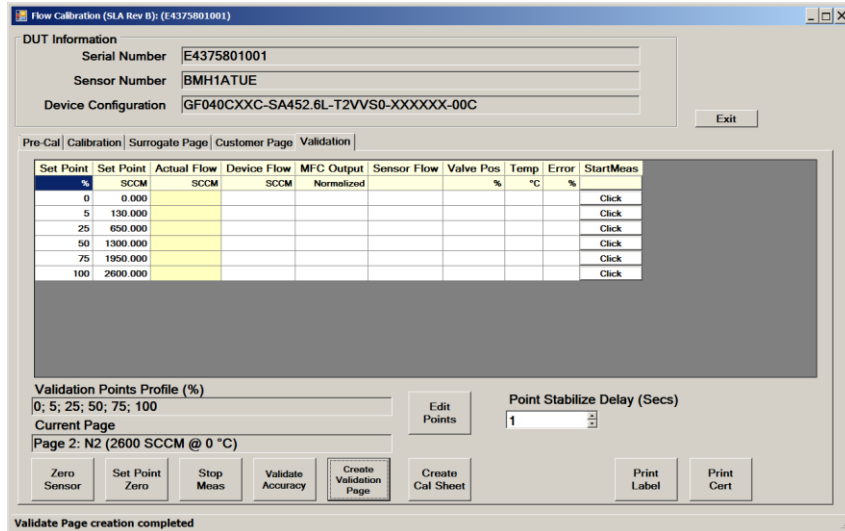

Figure 13-43 Calibration, Validation Tab with Validation Page, GF40

Next, you will continue to perform a validation (using nitrogen) as usual (as described in [Section 13.12](#)).

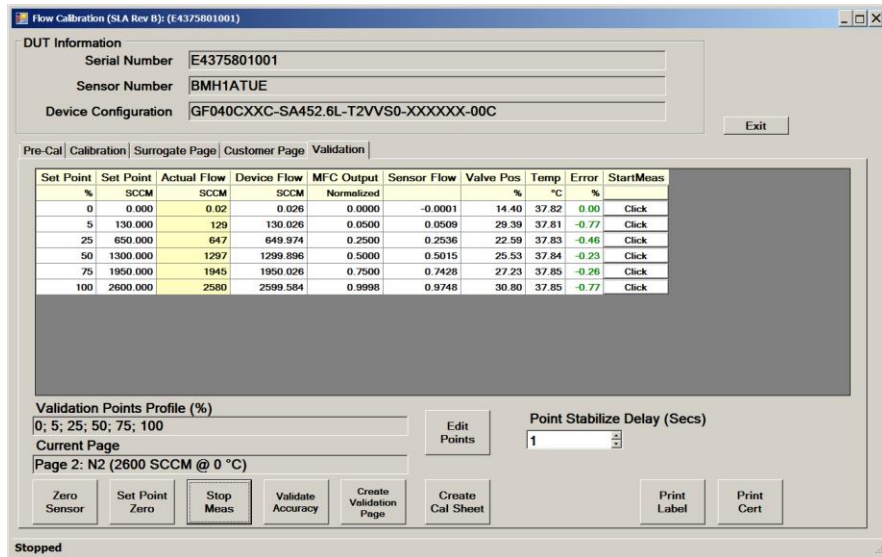

Figure 13-44 Calibration, Validation Tab, Validation Page with Data, GF40

Cal Sheet: You may create a cal sheet for a GF40 device if desired, in the same ways as with an SLA device in [Section 13.12](#). However, the usual practice for GF40 devices is to produce a cert sheet.

Cert Sheet: A cert sheet may be produced for a GF40 device by clicking the Print Cert button. The Cert Sheet Report Window will appear. From here the report can be printed or saved. Click Exit to return. (For cal setpoint data to appear on the label, the data must be present on the Validation tab.)

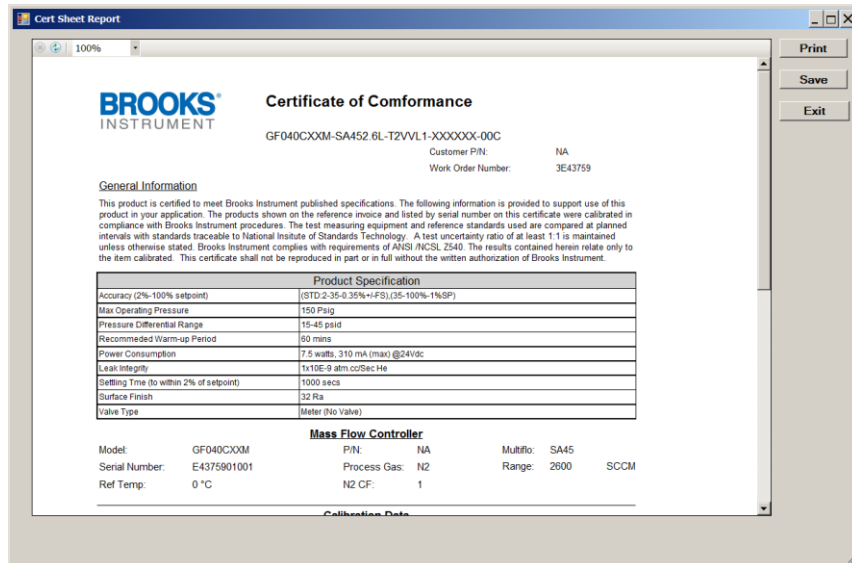

Figure 13-45 Cert Sheet Report Window

Print Device Label: A device label may be produced for GF40 device by clicking the Print Cert button. The Cert Sheet Report Window will appear. From here the report can be printed or saved. Printing the report does not save a copy. Click Exit to return. (For cal setpoint data to appear on the label, the data must be present on the Validation tab.)

On the other hand, for GF1xx devices, once a warp adjustment is applied to a flow page, the warp adjustment cannot be cleared/undone and the flow page cannot be restored to its previous state. It is recommended that warping not be applied more than four times to any flow page. At that time, you must delete the page and create a new one, then apply a new warp if desired.

The screenshot shows the 'Warp GP200' application window. At the top, there is a table listing flow pages:

PageNum	Process Gas	Range	FS Range	Units	Gas ID
1	N2	1000.00	1280.00	SCCM	13
2	N2	700.00	1280.00	SCCM	13
3	CO2	1160.00	1160.00	SCCM	25
4					
5	N2	1280.00	1280.00	SCCM	13

Below this table is a panel for 'Curve Fitting Method' with three options:

- Cubic Spline (Should have 5 data points)
- 3rd Order Polynomial (Requires at least 5 data points)
- 4th Order Polynomial (Requires at least 6 data points)

 To the left of this panel is a list of instructions:

- Select a curve fitting method.
- Fill out data pairs starting from top. First Setpoint must be between 0.5% and 15% of FS. Last setpoint must be between 75% and 110% of FS.
- Click Curve Fit.
- Review Data.
- Click Send.

 The main area of the window contains two data tables. The left table shows Setpoint (SCCM) vs Actual Flow (SCCM):

Setpoint (SCCM)	Actual Flow (SCCM)
116.000	116.000
290.000	290.000
580.000	580.000
870.000	872.000
1160.000	1160.000

The right table shows detailed warp data for the selected page (Page 3):

	pgWarpSetpoint	pgWarpCorrection	pgCardinalSetpoint	pgCardinalReading
1	0.00	1.0000000	0.00	0.00
2	0.04	1.0000000	0.03	0.03
3	0.07	1.0000000	0.06	0.06
4	0.11	1.0000000	0.10	0.10
5	0.14	1.0000000	0.13	0.13
6	0.18	1.0000000	0.16	0.16
7	0.21	1.0000000	0.19	0.19
8	0.25	1.0000000	0.23	0.23
9	0.28	0.9999000	0.26	0.26
10	0.32	0.9998000	0.29	0.29
11	0.35	0.9998000	0.32	0.32
12	0.39	0.9997000	0.35	0.35
13	0.43	0.9997000	0.39	0.39
14	0.46	0.9998000	0.42	0.42

At the bottom of the window, there are several buttons: 'Curve Fit', 'Save to File', 'Send To Device', 'Clear Warp', 'Exit', and 'Refresh'. There are also radio buttons for 'Proposed Values' (selected) and 'Device Values'. A status bar at the very bottom indicates 'Warp Completed'.

Figure 13-47 Warp (GP200)

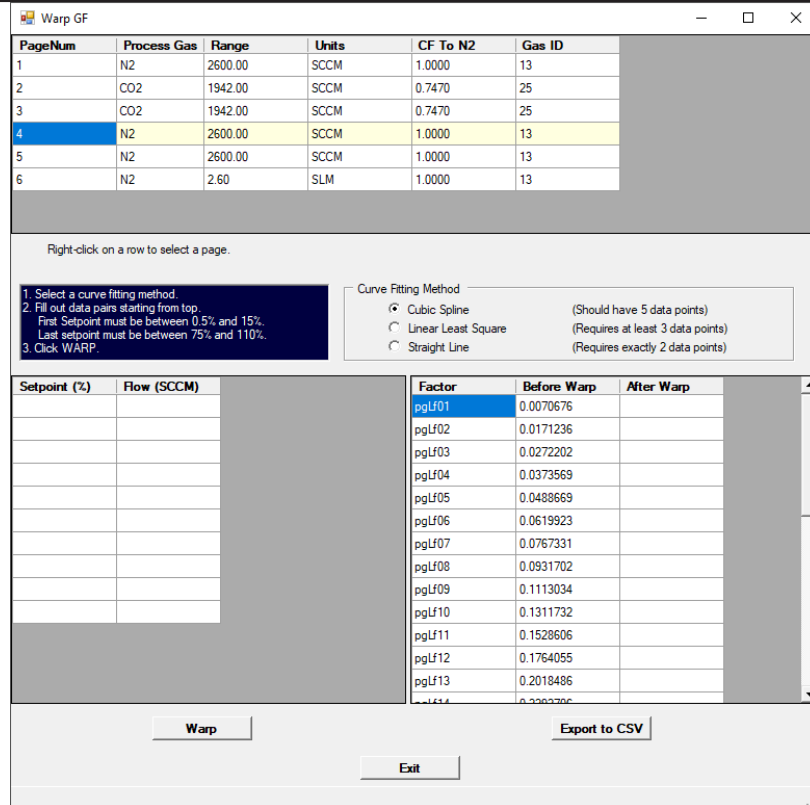

Figure 13-48 Warp (GF)

13.15 Bin Select (GF)

The Bin Select (GF) window is used to determine what bin is required for a specific device type, gas, outlet pressure, flow range, and reference temperature.

Bin selection is for GF devices only (GF40 and GF1xx). The Bin Select window may be opened regardless of whether a device is attached or not. If a device is attached, the window will open with that device type pre-selected.

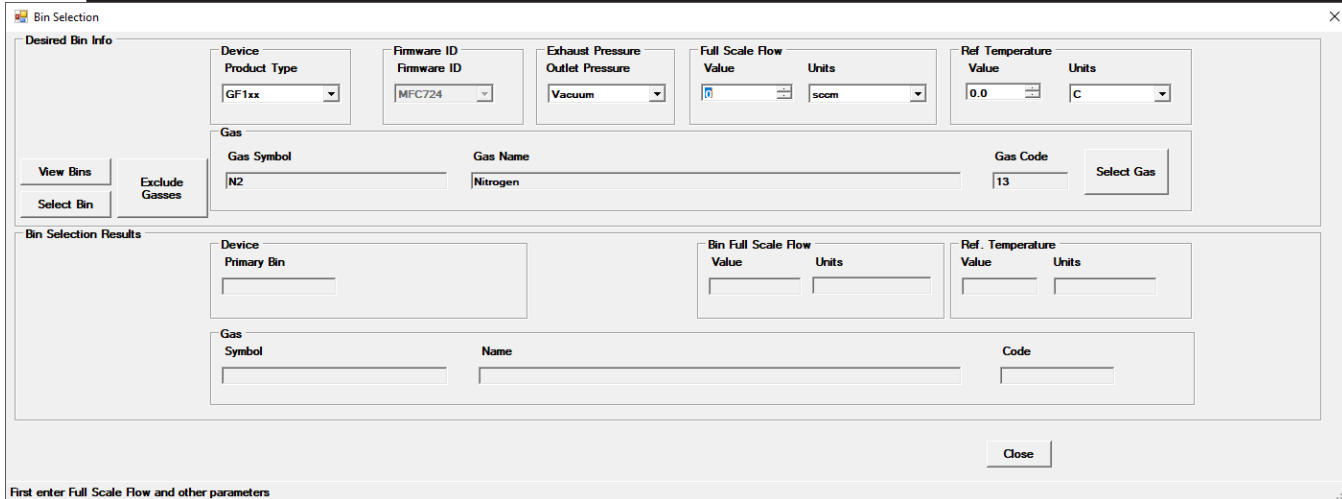

Figure 13-49 Bin Select (GF) Window

13.16 Pressure Controller Calibration

Pressure controller calibration is performed for PC device types (this is not performed for RT devices). The process is similar to the flow calibration process, although less complex. An example pressure calibration window is shown in Figure 13-50.

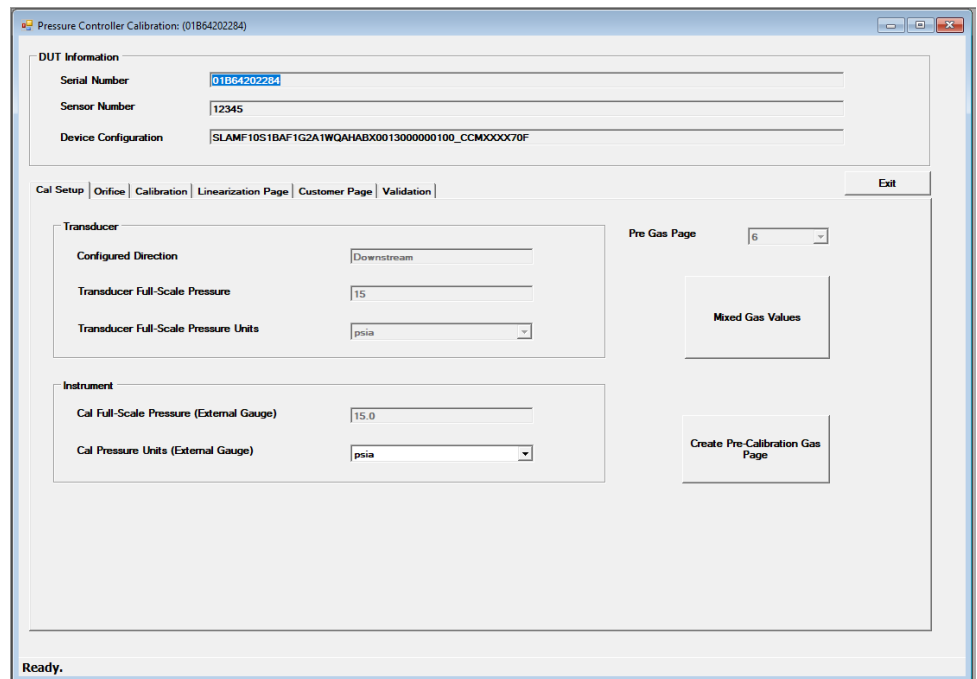

Figure 13-50 Pressure Calibration Window, Cal Setup Tab Shown

At the top of the window is the DUT information block. This information is read-only and is for information purposes only.

Below that are the tabs: Cal Setup, Orifice, Calibration, Linearization Page, Customer Page, and Validation. These tabs are normally executed in order from left to right. Select each tab by clicking on it.

Cal Setup Tab: The Cal Setup tab is performed first. The Cal Setup tab is shown selected in Figure 13-50.

Below the Cal Setup tab are a number of data fields. Most of these fields are read-only and are obtained from the device and its model code.

The Transducer Full-scale Pressure and its units are the rated value of the device's internal pressure transducer and can't be changed. The initial calibration steps will be performed for the full range of the pressure transducer. Later in the process, a pressure page may be created at a lower pressure value.

***NOTE:** Make sure the model code has been set up correctly prior to starting the calibration (see [Section 11.5](#)).

Mixed Gas: An SLA Rev B pressure controller device may be calibrated for a mixed gas. Click on the Mixed Gas Values button. A Mixed Gas Data Entry Form will open (reference Figure 13-32). This is the same form used with mass flow controller calibration for mixed gasses. Click on the Mixed Gas Values button, then enter the mixed gas information. Click load then Exit. Note that this may change the model code text box's gas code. Click on the Mixed Gas Values button before clicking the Create Pre-Calibration gas Page button.

The user will then click Create Pre-Calibration Gas Page. This will create an initial, temporary pressure calibration page to be used later in the calibration process.

Then the user is asked if they want to over-write the Pressure Response Tuning attributes with default values. These are values in the device, in the current page, that may have been previously set during a valve tuning operation for the current page. If the user had previously done a valve tuning operation (which creates these attributes), they may want to preserve those values. Click No to copy the current values from the current page to the new page 6 and continue with the calibration. Click Cancel to cancel the process. Or, click Yes to write default values to the new page 6 and continue with the calibration.

After clicking the Create Pre-Calibration Gas Page button, the page is created as page 6, and that page is activated as the current page.

Next, click the Orifice Tab.

Orifice Tab: The orifice tab is used as an aid in calculating the orifice factor and adjusted flow range when the gas used for valve tuning is different than the process gas. If the gas used for valve tuning is the same as the process gas, this tab may be ignored.

This tab is initially populated with process gas values from the device's model code. The user should edit their calibration gas values under the calibration text block. Then click the Calc Orifice Factor and Range button.

The orifice factor and equivalent adjusted flow range will be calculated, as well as the gas densities of the gasses. The new orifice factor and equivalent adjusted flow will eventually appear on the cal sheet.

***NOTE:** You must click the calculate button to recalculate the values.

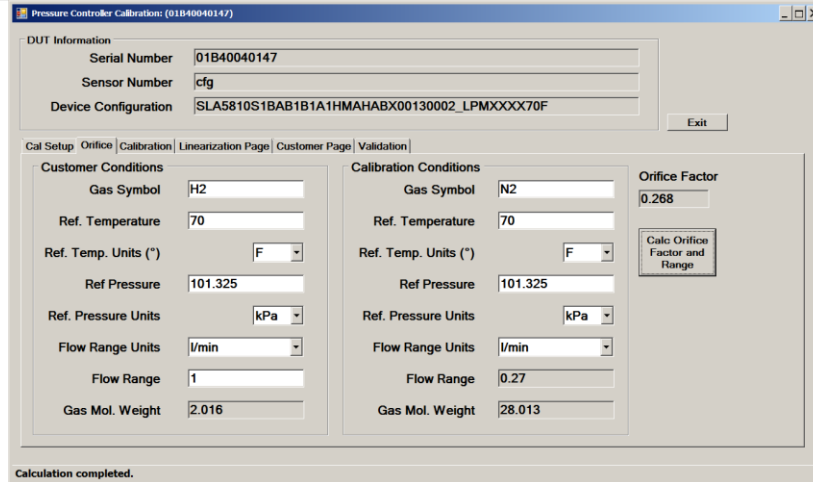

Figure 13-51 Pressure Calibration, Orifice Tab

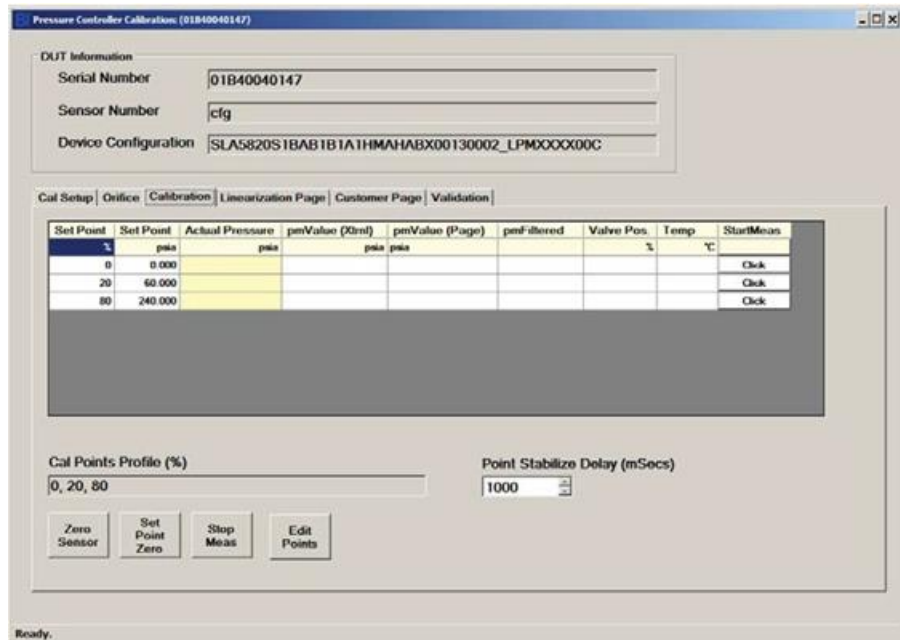

Figure 13-52 Pressure Calibration, Calibration Tab

Calibration Tab: The Calibration tab for pressure calibration is shown in Figure 13-52.

The Calibration tab performs a calibration using the Pre-Cal page (created in the previous tab) as a starting point. The Calibration tab is performed after the Pre-Cal page is created. If the device has no Pre-Cal page (page 6), this tab's calibration cannot be performed, and the tab will be disabled.

The Point Stabilize Delay value determines how much time delay occurs after clicking a set point button before the user may enter a pressure value. This is to prevent the user from entering a pressure value before the flow has stabilized after changing the set point. The delay for the Calibration tab is always the same value as for the validation tab (see Validation Tab section below).

The set point columns represent the set point values in percentage and absolute pressure units. The number and values of the set points are user-configurable. To change the set points, click on the Edit Points button. The Edit Setpoints operation is the same as for the flow calibration, except that for pressure calibration, it is recommended that all set points be $\leq 80\%$. For pressure calibration, two or three points is usually sufficient. The set of calibration points does not need to match the set of validation points.

In some scenarios, you may need to calibrate to a pressure range that is lower than the full range of the device's installed pressure transducer. For example, your system only supplies up to 1500 psi, but you have a device with a 3000 psi transducer. Or, you have a device with a 3000 psi transducer, but the device's valve is only rated to 1500 psi. In either case, you would need to limit the calibration of the device to 1500 psi. You can do this by changing the setpoints so that the highest set point is at 50% (1500 / 3000 psi).

The grid in the center of the Calibration tab is the calibration grid. Each row of this grid represents a set point. Each column represents a measurement at the set point. A number of set points will be measured and characterized to provide a correction for accuracy.

The first row of the grid contains the titles of the columns. The second row contains the units for each column. The pressure units are from the Cal Setup tab selection. The temperature units come from the model code.

Sensor Zero: If you intend to use the interpolated version of the sensor zero operation, you must do so before measuring any of these set points. After opening the Calibration window and clicking on a set point for the first time, a reminder for the sensor zero will appear. This will ask if you want to perform a sensor zero operation. If you click "Yes", the set point will not be measured, giving the user an opportunity to click on the Zero Sensor button. Clicking "No" will continue with the set point setup and will not again remind the user (until the calibration window is closed and re-opened).

Clicking the Zero Sensor button on the calibration window will perform the interpolated pressure sensor zero operation. The interpolated method is the preferred method.

The interpolated pressure sensor zero operation will measure two points along the range of the sensor. The points for a zero operation are at 80% and 0% of the full-scale transducer range. These two points will be used in a linear interpolation to calculate the offset correction at absolute zero pressure (0 psia).

First, the operation prompts the user to set up their system for calibration, including pressure and vacuum on the inlet and outlet, as needed. The setup requires an external pressure meter instrument as well.

Next, at the high point the software prompts the user to set up the pressure. The window shows the live reading of device pressure and valve position for reference. The user is instructed to read the external meter and manually enter the pressure value (in user's units) onto the form. (See Figure 13-53).

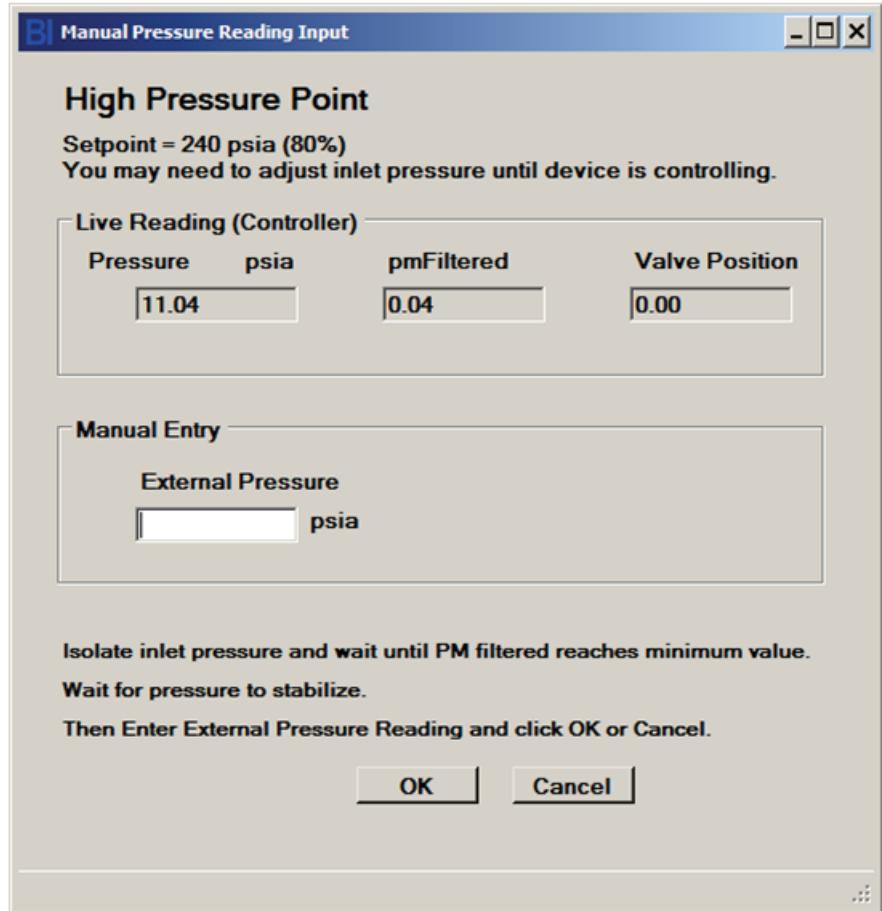

Figure 13-53 Pressure Sensor Zero, High Point

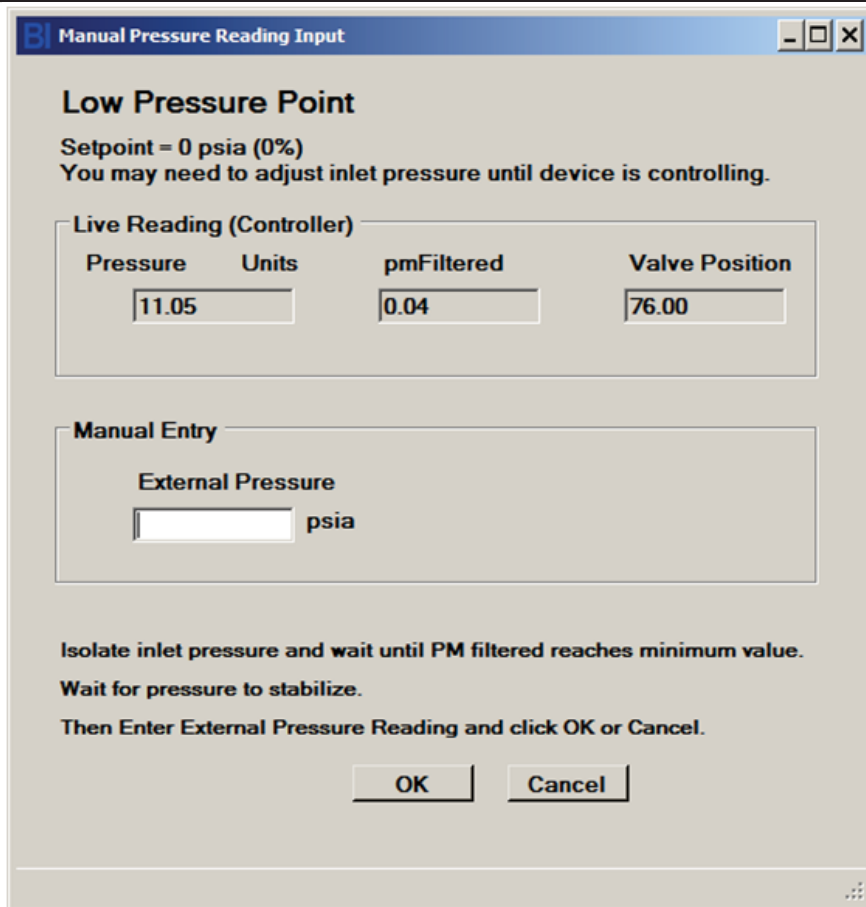

Figure 13-54 Pressure Sensor Zero, Low Point

Next, at the Low point (0%) the software prompts the user to set up the pressure to 0% pressure. The window shows the live reading of device pressure and valve position for reference. The user is instructed to read the external meter and manually enter the pressure value (in user's units) onto the form. (See Figure 13-54).

After this, a final measurement at zero pressure again will be presented in the same manner, for a final, corrected measurement at zero pressure. This completes the pressure sensor zero operation.

Next, after the sensor zero operation, the calibration setpoints can be measured.

The calibration is started by clicking on a Click button in one of the rows under the StartMeas Column (see Figure 13-55). Clicking on one of these buttons starts a live measurement at the set point of the clicked row. The software will set the device's set point to the value in the set point column, and then continually reads the device's output including pressure, temperature, and valve position for reference.

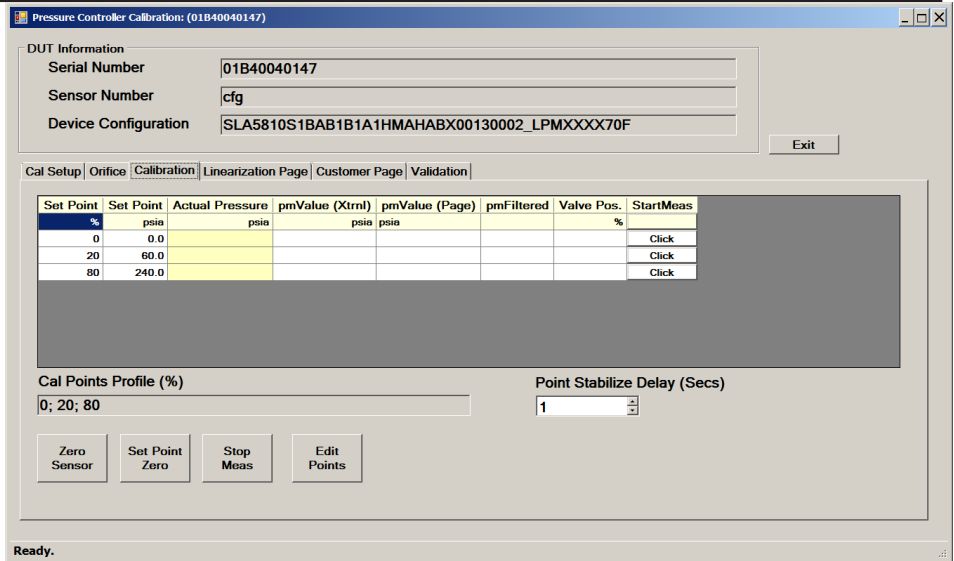

Figure 13-55 Pressure Calibration, Calibration Tab

The user must manually enter the actual pressure into the Actual Pressure column, the column with a dark yellow background. An external pressure meter is required. The user will read the pressure measurement from the external meter and manually type it into the Actual Pressure column.

To go to another row (another set point), click a Click button in one of the other rows under the StartMeas Column. All rows must be filled out to continue the calibration beyond this tab. Set points can be completed in any order.

To stop live readings, click the Stop Meas button.

The Zero Set Point button changes the device set point to 0% (useful if the set point list does not contain 0%) and stops the live measurements.

When you have filled out the grid info for all set point rows, you should click Stop Meas. Then you can proceed to the next tab, by clicking on the Linearization Page tab.

Linearization Page Tab: The Linearization Page tab is performed next. The Linearization Page tab is shown in Figure 13-56.

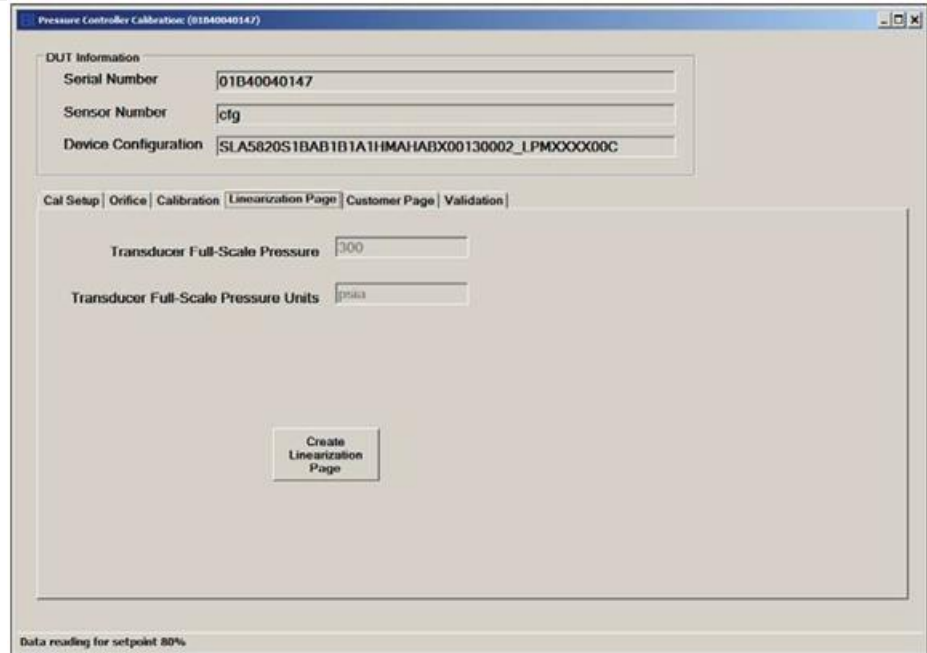

Figure 13-56 Pressure Calibration, Linearization Page Tab

Click the Create Linearization page button to create the linearization page. The linearization is saved to page 6 and that page becomes the active page.

Customer Page Tab: The Customer Page tab is performed next. The Customer Page tab is shown in Figure 13-57.

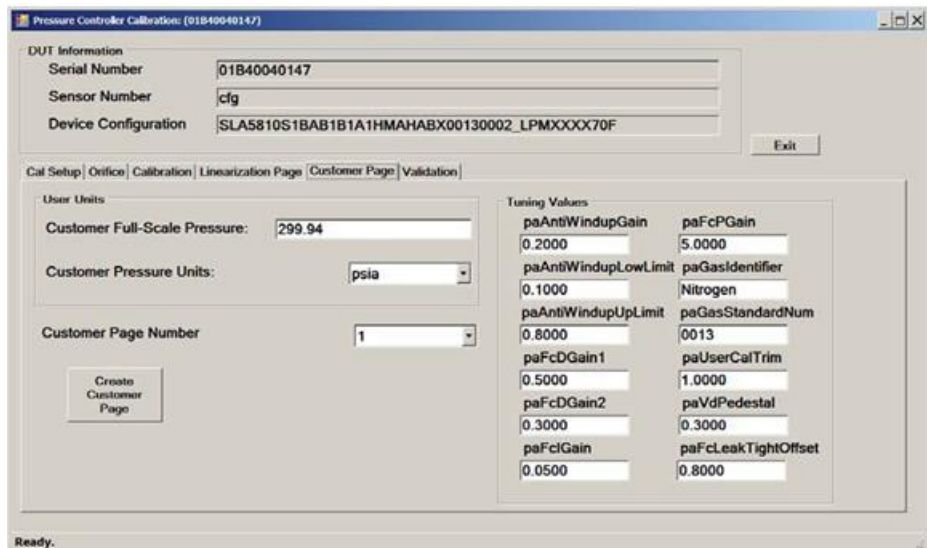

Figure 13-57 Pressure Calibration, Customer Page Tab

The Customer Page tab is where the user can customize some settings. The Customer Page uses the linearization page (page 6, created in the Linearization Page tab) and creates a user-specified “customer page”. Multiple customer pages can be created from the same linearization page without performing a full calibration again.

The Customer Full-Scale Pressure is the pressure to be used for the final full-scale pressure on the device (after page creation). This value can be at the transducer full-scale pressure, or lower. The Customer Pressure Units drop-down box is user-selectable.

The Customer Page Number can be any number from 1 to 6. It is recommended that you not select page 6 to preserve the linearization page for future use in creating other new pages, if desired. However, if you are done with page 6 you may overwrite it at this point if desired.

The tuning values block contains the tuning values presently in the device. These can be changed here if desired. However, if these values need to be changed, they would typically be changed during a response tuning operation (see **Section 13.18**).

Clicking Create Customer page creates the page as the page number selected. That page number will be active afterwards.

Validation Tab: The Validation tab is shown selected in **Figure 13-58**.

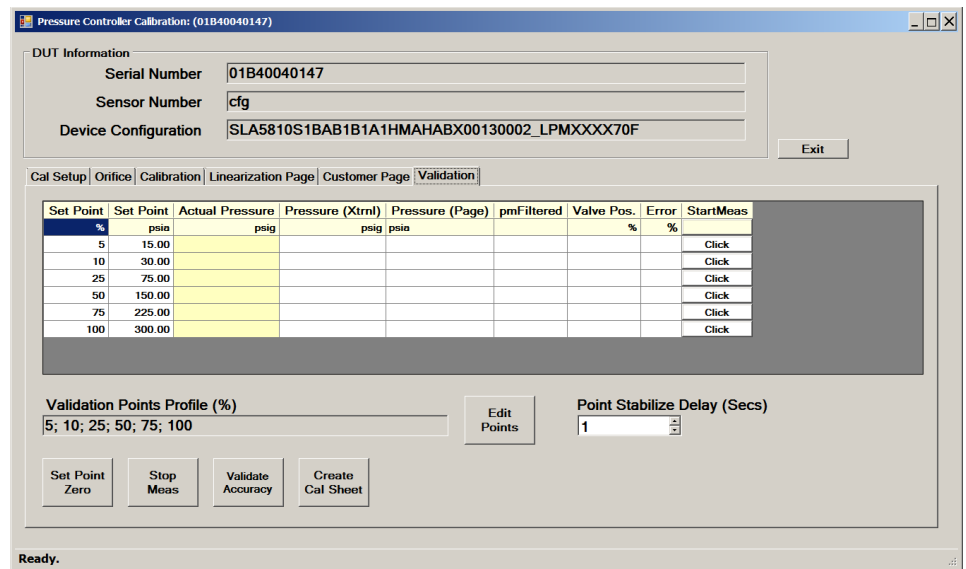

Figure 13-58 Pressure Calibration, Validation Tab

The Validation tab performs a validation of a customer page's calibration. The page verified is the current page (see **Section 13.10** to select a page). It is assumed that the current page is the customer page. The Customer page was created in the Customer Page tab. The Validation tab is performed after the Customer page is created. If the device has no customer page, this tab's validation cannot be performed and the whole tab will be disabled.

The grid in the center of the Calibration tab is the validation grid. Like the calibration grid, each row of the validation grid represents a set point. Each column represents a measurement. A number of set points will be measured and checked for accuracy.

The set point columns represent the set point values in percentage and absolute pressure units. The number and values of the set points are user-configurable. To change the set points, click on the Edit Points button. The Edit Setpoints window appears, the same way as for calibration set point selection (see **Figure 13-27** to set the collection of set points).

The Point Stabilize Delay value determines how much time delay occurs after clicking a set point button before the user may enter a flow value. This is to prevent the user from entering a flow value before the flow has stabilized after changing a set point. The delay for the Validation tab is always the same value as for the Calibration tab (See Calibration Tab section above).

The first row of the grid contains the titles of the columns. The second row contains the units for each column. The pressure units are the user's preference from the Customer Page tab and temperature units are from the device's model code. Columns without units are unit-less or ratio values.

Like the calibration tab, the validation for a set point is started by clicking on a Click button in one of the rows under the StartMeas Column. Clicking on one of these buttons starts a live measurement at the set point of the clicked row. The software will set the device's set point to the value in the set point column, and then continually read the device's output including pressure, temperature, and valve position.

Like the calibration tab, in the validation tab, the user must manually enter the actual pressure into the Actual Pressure column, the column with a dark yellow background. An external pressure meter instrument is required. The user will read the pressure measurement from the external meter instrument and manually type it into the Actual Pressure column.

To go to another set point, click a Click button in one of the other rows under the StartMeas Column. All rows must be filled out to complete the validation and create a certification sheet. Set points can be completed in any order.

Once a user types in an actual pressure value, the error percentage is automatically calculated and updated for the current row. The accuracy calculated is the set point pressure compared to the actual, external pressure reading.

Clicking the Validate Accuracy button stops live measurements and recalculates the accuracy for all rows (all set points).

At any time, to stop live readings, click the Stop Meas button.

The Zero Set Point button stops live measurement and changes the device set point to 0% (useful if the set point list does not contain 0%).

When you have filled out the grid info for all set point rows, you should click Stop Meas. Then, if desired, you can proceed to print a certification report, (see next paragraph).

Create Cal Sheet: Once the validation is completed, the user can print out a cal sheet. This is a report showing the validation results data and some custom user information.

Click the Cal Sheet button. A window will open allowing the user to choose a set of custom data items that will appear on the report, in addition to the validation data. The user may select, edit, and save the set of custom report data (See Figure 13-59).

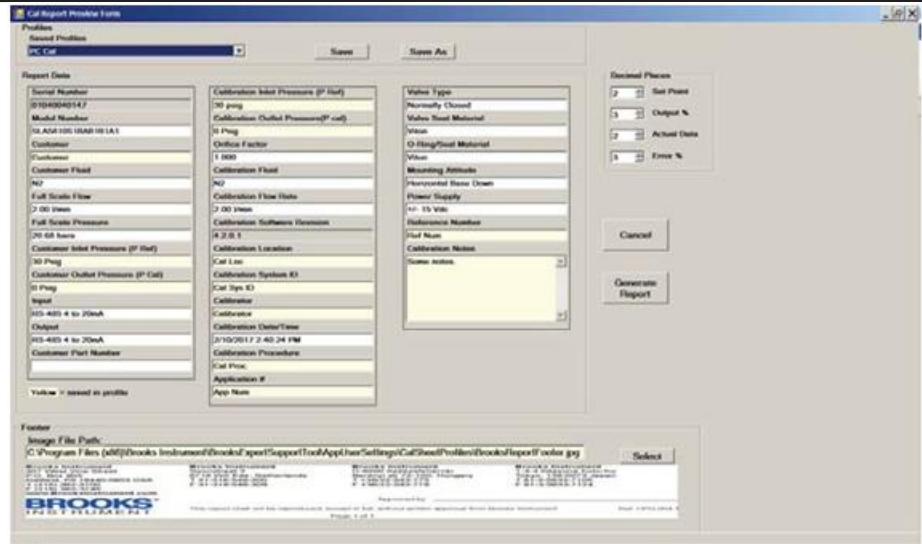

Figure 13-59 Pressure Calibration, Cert Sheet Options Window

After this, a preview of the report information will be displayed.
From there, the user may view, print or save the report to file.

Pressure Controller Calibration Report Display

Production Calibration Data Sheet

Device Information	Calibration Information	Mechanical Information
Serial Number 01B40040147	Calibration Inlet Pressure (P Cal) 300 PSIA	Valve Type Normally Closed
Model Number SLA	Calibration Outlet Pressure (P Ref) 0 PSIA	Valve Seal Material Nylon
Customer Bridges Hatfield	Orifice Factor 1.0000	O-ring/Seal Material Nylon
Customer Fluid Nitrogen	Calibration Fluid Nitrogen	Mounting Altitude Horizontal Base Down
Full Scale Pressure 300 PSIA	Calibration Flow Rate 2.000 LPM	Power Supply +/- 15 V/00
Full Scale Flow 2.000 LPM	Calibration Software Revision 4.0.0.1	Reference Number 1213
Customer Inlet Pressure (P Cal) 300 PSIA	Calibration Location Hatfield	Calibration Notes -Test 1
Customer Outlet Pressure (P Ref) 0 PSIA	Calibration System ID USMAT-0215Q3 V	
Input 0 to 10V	Calibrator D. Miller	
Output 0 to 10V	Calibration Date/Time 5/9/2016 4:15:30 PM	
Customer Part Number SLA5520S1BAB1B1A1	Calibration Procedure None	
Application # SLA		

Calibration Check Data

Setpoint (%)	Output (%)	Flow	Error (%Rate)
50.00	3311.60.000	1.500000	221.77
25.00	3311.60.000	7.500000	48.15
50.00	3311.60.000	15.000000	23.08
75.00	3311.60.000	22.500000	15.72
100.00	3311.60.000	30.000000	12.04

Setpoint vs. %Full Scale Error (Linearity and hysteresis: +/- % of F.S.)

Calibration of this device is done at full scale range of the pressure transmitter. The calibration check is done at the customer specified conditions.

Brooks Instrumentation: 200 South Union Street, Houston, TX 77002-9885 USA, P: 281-880-0745, www.brooks-instrumentation.com
 Brooks Instrumentation: 200 South Union Street, Houston, TX 77002-9885 USA, T: 214-210-548-300, F: 214-210-548-300
 Brooks Instrumentation: 400000, Széchenyi utca 10, H-1024 Budapest, Hungary, T: +3630-944-770, F: +3630-944-770
 Brooks Instrumentation: 1-800-541-9910, 1-800-541-9910, T: 813-8633-7100, F: 813-8633-7124

Approvals: _____
 This report shall not be reproduced, stored in a retrieval system, or transmitted in any form or by any means, electronic, mechanical, photocopying, recording, or by any information storage and retrieval system, without written approval from Brooks Instrumentation. (Ref: DRN0041)
 Page 1 of 1

Figure 13-60 Pressure Calibration, Cert Sheet Preview Window

13.17 RT Device Calibration

The flow calibration process for an RT device is exactly the same as for an MFC device, with only a few minor exceptions.

RT devices may be operated in pressure control mode. However, the semi-automated calibration process consists of temporarily placing the device into flow control mode for calibration purposes, (which makes the device simulate an MFC). This allows the RT device to use its internal valve to help calibrate for accurate flow measurement. Then, after calibration, it may switch the device back into pressure control mode.

For an RT device (which uses an external pressure sensor), there is no pressure control calibration process or pressure sensor zero process, other than the RT/Auxiliary Input adjustment (see [Section 13.7](#)).

At the end of the (flow) calibration process for RT device, an opportunity is made available for the user to create a default pressure page if necessary. The Pressure Application page selection window is brought up. (See Figure 13-61). The user should ensure that at least one pressure page exists. If none exist, the user may create a new page by clicking the Create Default page button, then selecting the range and units they desire that corresponds to maximum voltage from the RT external pressure sensor. The user also selects a pressure page number.

Then the user should also perform the RT/Auxiliary Input adjustment (see [Section 13.7](#)).

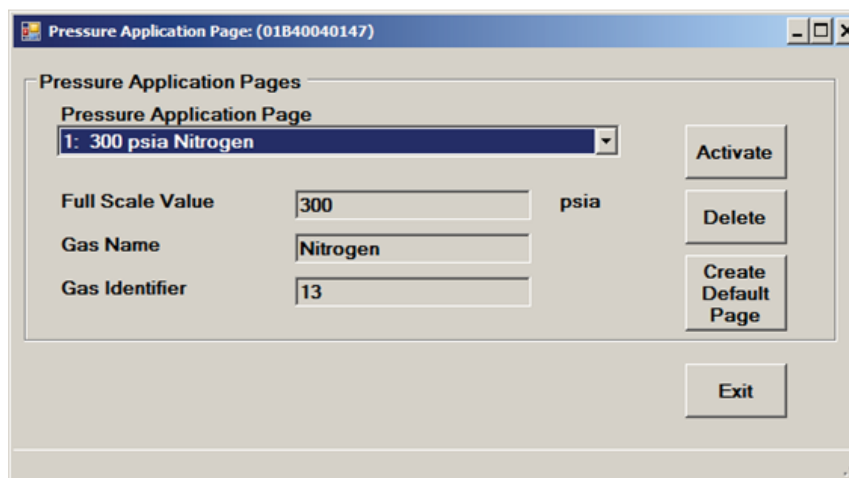

Figure 13-61 Pressure Page Window

13.18 Response Tuning (Flow)

The **Response Tuning** menu is where the user can optimize the timing response of the valve. MFM devices do not have a valve, so response tuning is not applicable. Response tuning optimizes the dynamic response of the device to changes in set point. You can use this feature to eliminate undesired under-and overshoot.

Users can tune valves on either flow or pressure control devices. The process is very similar for both. Flow devices (MFC's) are tuned in flow control mode, and pressure devices (PC's) are tuned in pressure control mode. RT devices may be tuned in either mode: first select the mode (Device Control->RT Control Mode menu). This section describes the process for response tuning for flow controllers. The following section describes the process for response tuning for pressure controllers.

***NOTE:** For devices calibrated at the factory, response tuning adjustments should typically not be necessary, as calibrations are performed to the device's specified process conditions. If you do want to adjust the response tuning, it is strongly recommended that you only adjust the PID Kp and Ki (proportional and integral gain). Only in rare occasions the Kd1 and Kd2 (derivative gain) values might improve performance. Make sure that you have saved the device configuration prior to adjusting these values. For Brooks Expert Support Tool training, which includes training for response tuning, contact your local Brooks service representative.

Pedestal Tuning: The valve tuning process typically starts with pedestal tuning. Tuning the pedestal sets the valve's offset and has a great effect on the response to a set point change.

The way of calculating the pedestal value is different for normally closed and normally open valves.

For MFC and RT devices, the basic procedure for finding the pedestal value is to find the valve drive value at the point where the device starts flowing gas. This can easily be done with MFC and RT devices; however, for a PC device, it is more complicated. For an MFC or RT device, you configure a set point of 1%. If the device has a wrong pedestal, it might take some time for the device to reach the 1% flow. You might be able to speed this up by first configuring a set point of 10% and then going down to 1%.

For a pressure controller, configuring a set point will not work. You have to use the manual valve control mode in the Device Control -> Valve Control menu. Find the point at which the device starts flowing gas using the valve position field. Use an external flow meter to measure the flow and try to get down to ~1% of the maximum flow of the pressure controller at a low pressure.

If the device has a normally closed valve (i.e., closed when unpowered), the pedestal is equal to the valve drive in percent at 1% flow, minus 7%. If the device has a normally open valve (i.e., opened when unpowered) the pedestal is equal to the inverse of the valve drive in percent at 1% flow, plus 7% (100% - 'valve drive in %' - 7%).

Valve Tuning: The valve tuning process typically involves cycling the flow or pressure between a high and a low set point value, while watching and adjusting the parameters that control the response of the valve. The objective is to minimize overshoot and undershoot.

To tune the device's response, you will set up a square wave for the set point. You will then make adjustments to tuning parameters to make the actual flow graph match the set point's square wave.

The user will open the main graph window (see **Section 8.4**) and start the monitoring. For valve tuning, it is recommended that you choose % as your units of display for setpoint, pressure and flow. Make sure the graph can display your range of flow values (Settings->Graph Options menu).

Then the user will open the Calibration->Valve Tuning menu and make adjustments there while watching the performance on the main graph. Position the Graph window so that you can see the Tuning and Graph windows at same time.

The flow response tuning setup window is shown in Figure 13-62 and the pressure controller valve response tuning setup window is shown in Figure 13-63.

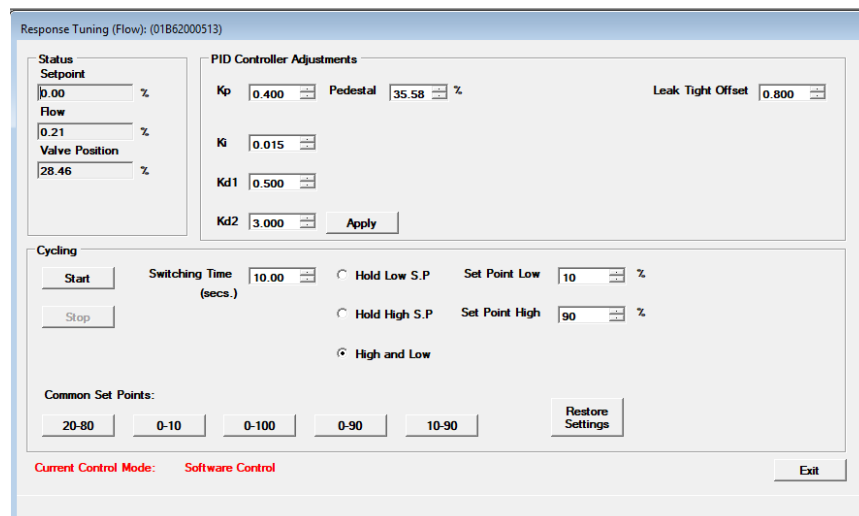

Figure 13-62 Flow Response Tuning Setup Window

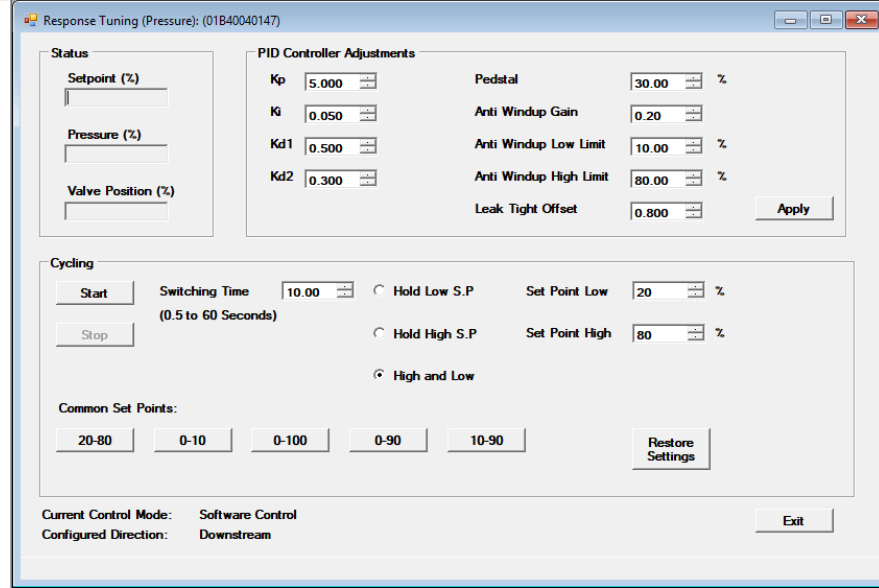

Figure 13-63 Pressure Response Tuning Setup Window

Set up the set point square wave in the Cycling block of the Tuning window. Pick high and low set points that are at the expected range of your process application.

The Cycling block in this window allows the user to select parameters determining the high and low set point of the cycling. The Switching time determines how often the set point changes state during the cycling. Choose a switching time that allows enough time for the flow response to settle after the setpoint changes. The Start button starts the cycling and the Stop button stops the cycling.

*Note: If you are adjusting a meter model (MFM), use a separate flow controller to regulate the set point cycling.

Apply gas flow to your device.

Click the Start button to begin cycling.

Observe how closely the actual flow matches the set point square wave. Start making adjustments using the PID Kp and Ki (proportional and integral gain) values.

The Status block of the valve response tuning form shows the status during the cycling.

Start making adjustments using the PID Kp and Ki (proportional and integral gain) values. (Do not adjust the Flow Control K-up and K-down values.) The Adjustments block is where the adjustments are made during the cycling. When changing values, always remember to click Apply.

If you are having difficulty getting the actual flow graph to look like the setpoint square wave, you can restore the initial settings that were in effect when the window was opened by clicking the Restore Settings button.

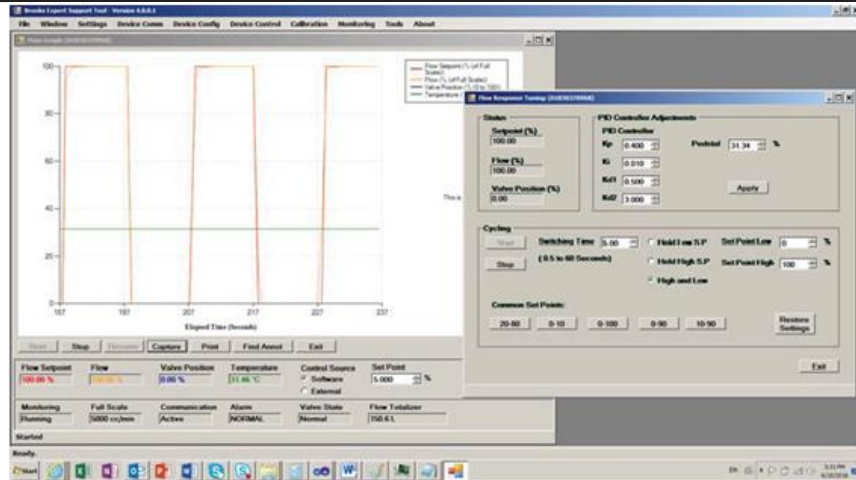

Figure 13-64 Flow Valve Tuning Operation

Effect of Kp and Ki Values on Flow Control: The following screens show some examples of what the flow graph looks like when Kp and Ki values are too high or too low.

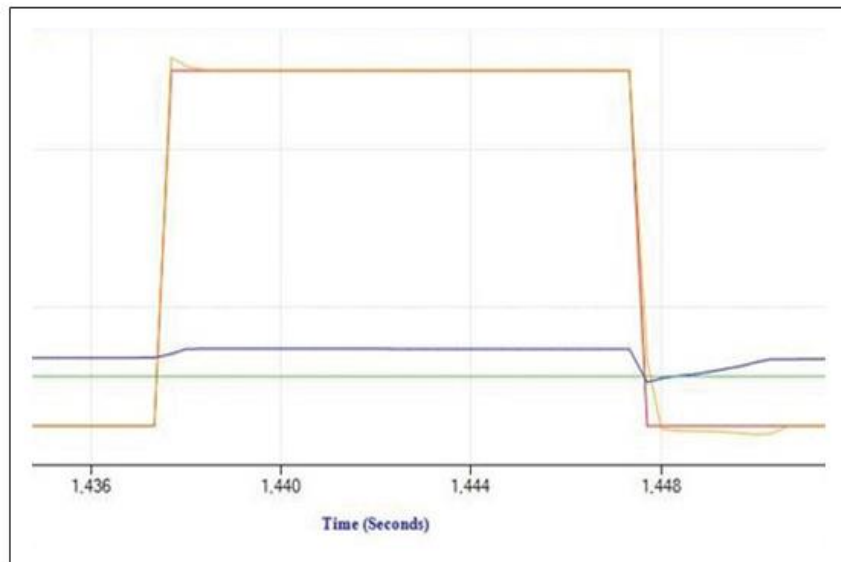

Figure 13-65 Valve Tuning, Kp Value Too High, or Ki Too Low

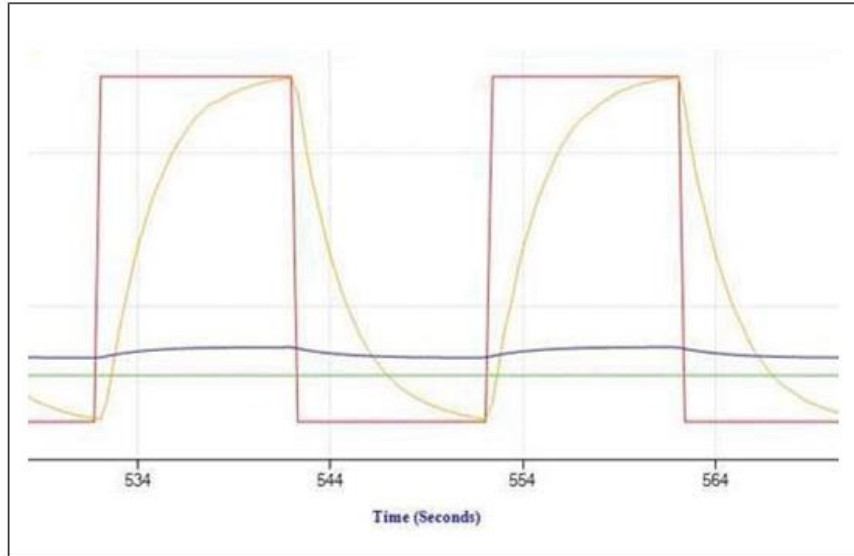

Figure 13-66 Valve Tuning, Kp and Ki Values Too Low

Start with the original PID settings. Note that these may vary per device.

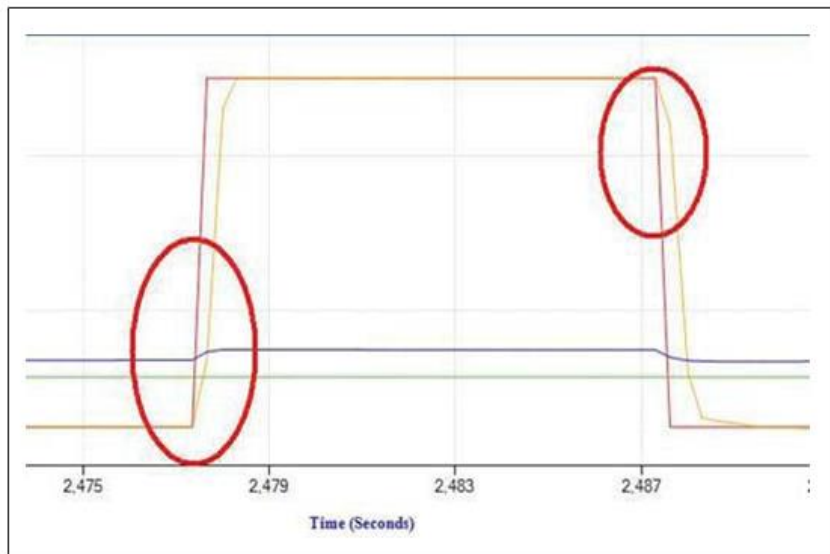

Figure 13-67 Original PID Settings

Increase the Kp value, the slope of the red circled part will slightly increase.

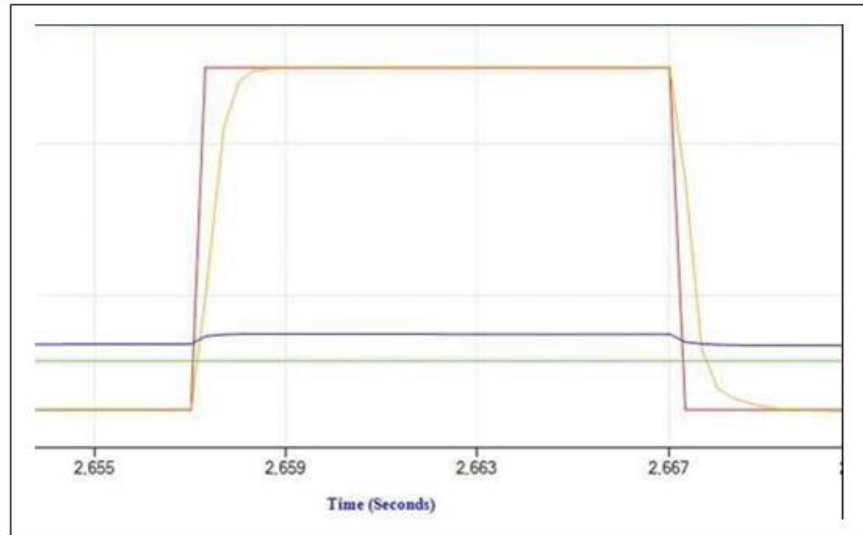

Figure 13-68 Valve Tuning, Increase Kp Value

Increase the Ki value, to move the flow curve towards the set point curve. This change will be the most visible but might lead to overshoot and undershoot.



Figure 13-69 Valve Tuning, Overshoot

***NOTE:** If you need a higher data sample rate (resolution), change the graph options to show fewer parameters (see [Section 7.1](#)). Uncheck the **Auto Show Default Parameters** check box and select only the parameters you need to view. Unchecking the Valve Position parameter can yield significant increases in sample rate

13.19 Response Tuning (Pressure)

Pressure response tuning optimizes the dynamic performance of the pressure controller device to changes in set point. You can use this feature to eliminate undesired undershoot and overshoot.

Note: PID values for pressure controllers are tuned in the factory. However these PID values might not be optimal for the customer's setup. If you do need to adjust the response tuning, it is strongly recommended that you only adjust the PID Kp and Ki (proportional and integral gain) and anti-windup low/high limits. Only in rare occasions the Kd1 and Kd2 (derivative gain) values might improve performance. Anti-windup gain can be disabled by setting the anti-windup gain to 0. Do not use any other value than the default of 0.2 or 0. Tuning the anti-windup limits will help in solving undershoot and/or overshoot without slowing down the signal too much.

Make sure that you have saved the device configuration prior to adjusting these values. For Brooks Expert Support Tool training, which includes training for response tuning, contact your local Brooks service representative.

To tune the device's response, you will set up a square wave for the set point. You will then make adjustments to tuning parameters to make the actual pressure graph match the set point's square wave.

Make sure that the valve pedestal value is correct, use the procedure in the "Pedestal Tuning" section above to get the correct value.

To tune the device's response:

1. Open the Tune menu and click the Pressure Response Tuning button to display the Pressure Response Tuning window.

Figure 13-70 shows some tuning values.

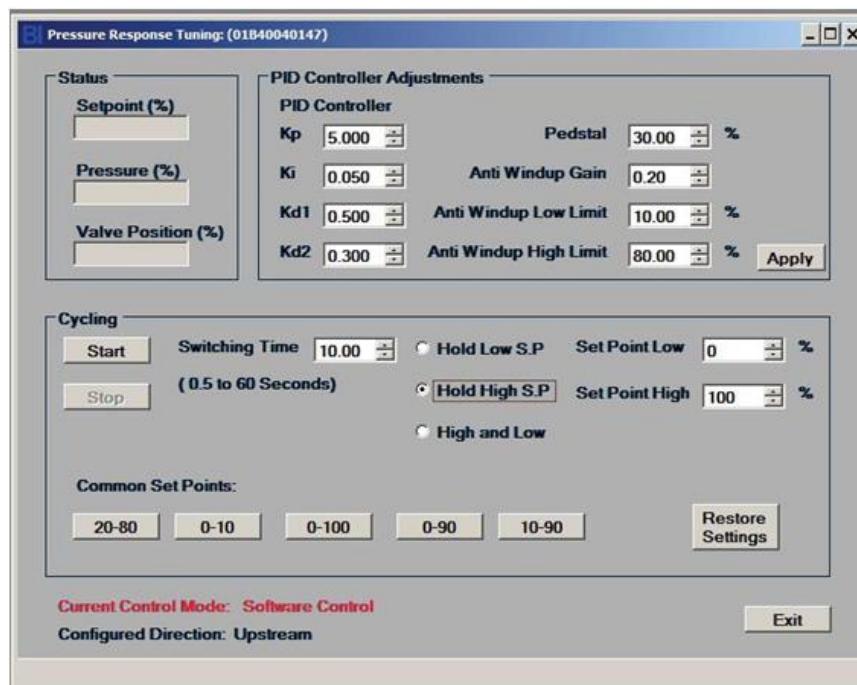

Figure 13-70 Pressure Valve Tuning, Default Values

2. Position the Graph window so that you can see the Tuning and Graph windows at same time.
3. Set up the setpoint square wave, as shown in Figure 13-71 below. You should pick high and low set points that are at the expected range of your process application



Figure 13-71 Pressure Valve Tuning, Cycle Settings

***NOTE:** The Brooks Expert Support Tool is intended to be used for thermal mass flow controllers and thermal mass flow meters. If you are adjusting a meter model, use a separate flow controller to regulate the set point cycling.

4. Click the Start button to begin flow.
5. Observe how closely the actual flow matches the set point square wave.
6. Start making adjustments using the PID Kp and Ki (proportional and integral gain) values.

Effect of Kp and Ki Values on Pressure Control: The following screens show some examples of what the pressure graph looks like when Kp and Ki values are too high or too low.

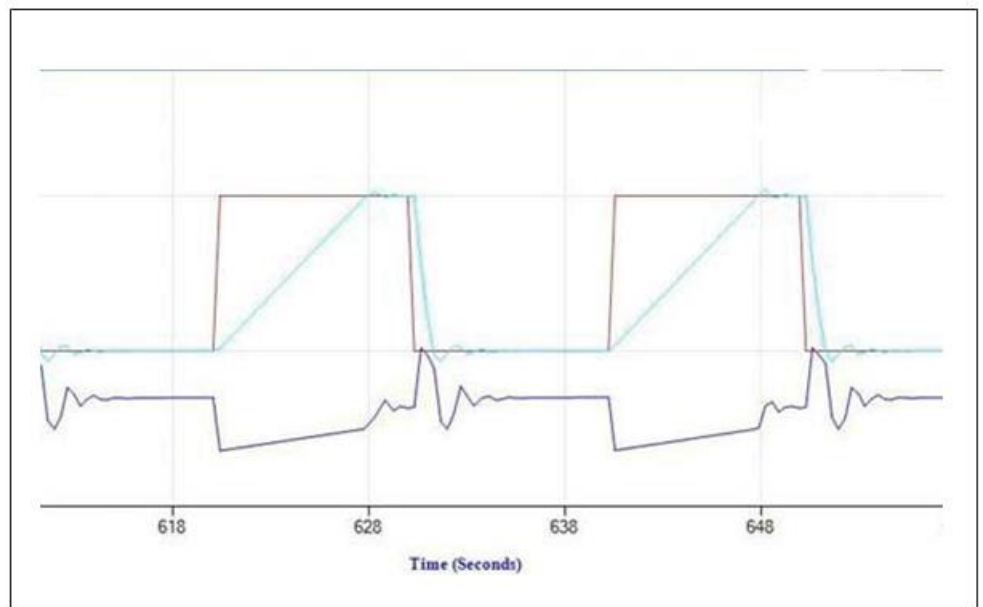

Figure 13-72 Pressure Valve Tuning, Kp Low

A Kp value that is too low leads to oscillations in both the pressure reading and valve drive.

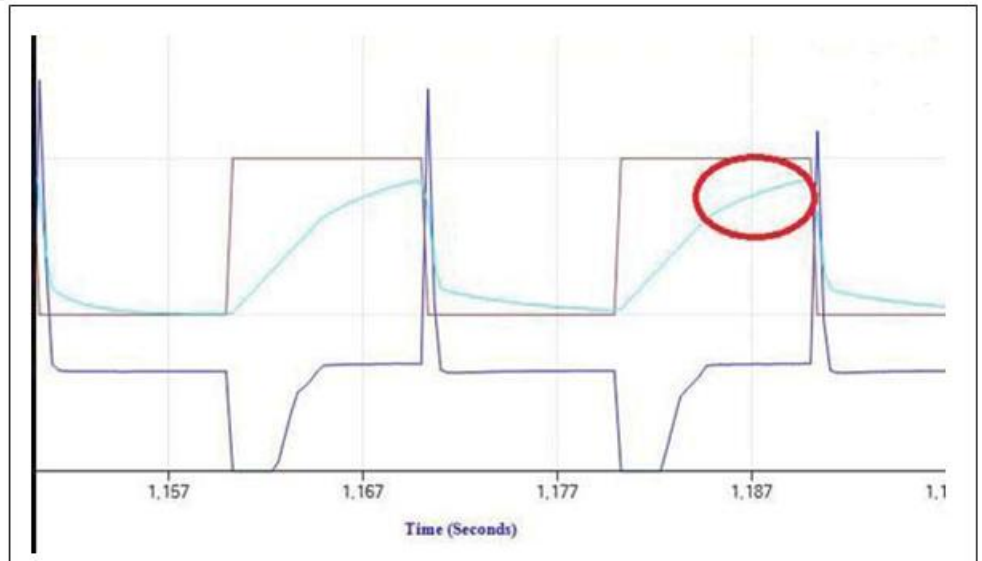

Figure 13-73 Pressure Valve Tuning, Ki Low

A Ki value that is too low leads to a pressure reading curve that does not reach its end value in a straight line; see red circled part.

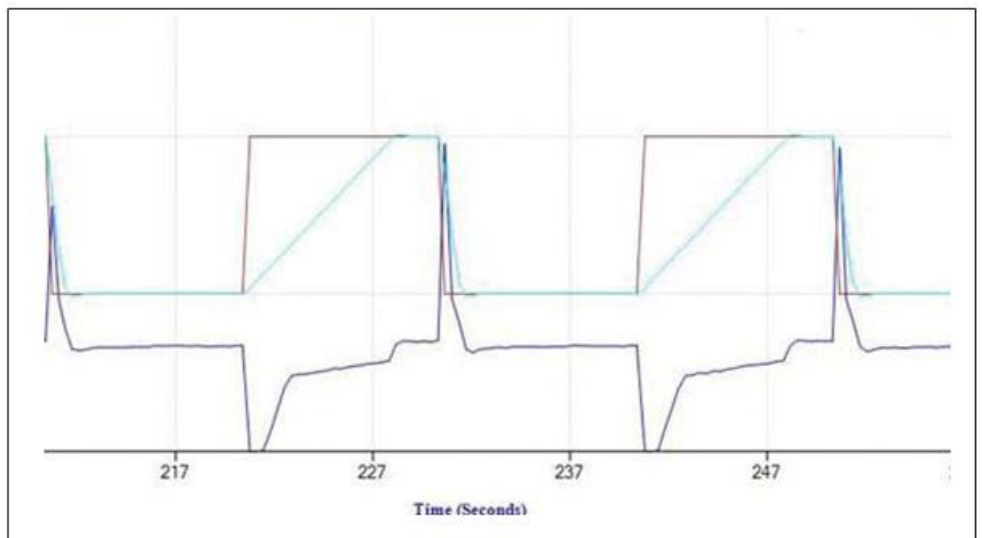

Figure 13-74 Pressure Valve Tuning, Correct Kp and Ki Values

Effect of Anti-Windup Settings on Pressure Control: Tuning the anti-windup low and high limits will remove any under- or overshoot of pressure response to a set point. The values of these limits are different for a normally closed versus a normally opened valve. By definition, the high limit should be higher in value than the low limit in all cases.

Normally Closed Valve: For a normally closed valve, the default value of the low limit is 5% below the pedestal value. The high limit is the valve drive at the maximum pressure and maximum flow, plus a tolerance of 10%.

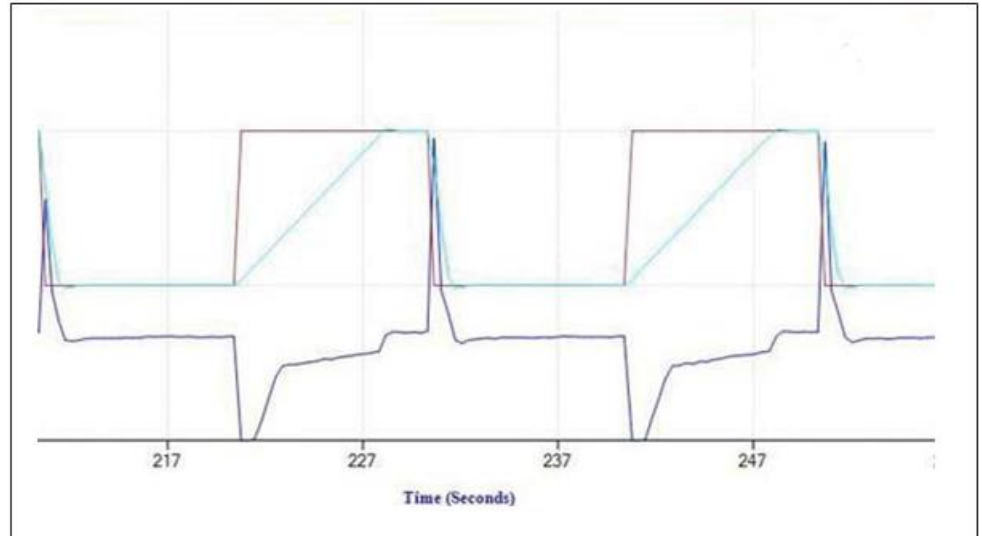

Figure 13-75 Anti-windup for a Normally Closed Valve

Normally Open Valve: For a normally open valve, the default value of the high limit is 5% above the pedestal value. The low limit is the inverse (100%-valve drive in percent) of the valve drive at the maximum pressure and maximum flow, minus a tolerance of 10%.

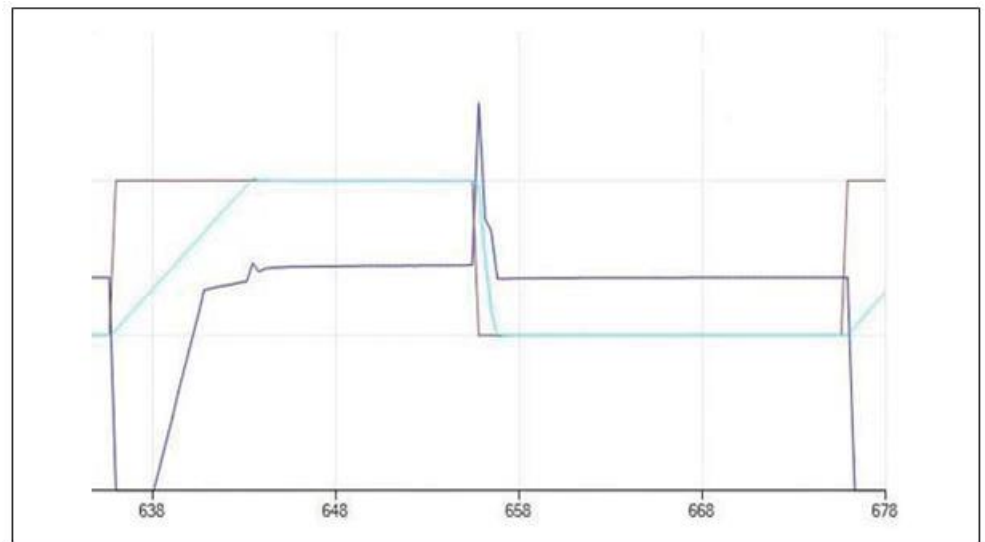

Figure 13-76 Anti-windup for a Normally Open Valve

***NOTE:** If you need a higher data sample rate (resolution), change the graph options to show fewer parameters (see [Section 7.1](#)). Uncheck the **Auto Show Default Parameters** check box and select only the parameters you need to view. Unchecking the Valve Position parameter can yield significant increases in sample rate

13.20 Print Top Label

BEST software can be used to print a simple label used for the top of the device. Note that this is the small label, not to be confused with the label for the side of the device for GF40 devices after calibration.

The label by default displays the device serial number, gas, range and range units of the current page of the device. However, the user may optionally substitute any text.

Some typical labels are:

1. Brady PN: THT-59-423-10 3" core 1x0.5 (1 label wide)
2. Brady PN: THT-59-533-2.5-SC 1" core 1x0.5 (3 labels wide)

A license is not required.

This feature is supported by all device types (including flow controllers and pressure controllers). A device does not need to be attached to print a top label.

If a device is attached when this window is opened, the windows is populated with the device serial number, gas, range, and flow units of the current page of the device. However, the user may optionally substitute any text.



Figure 13-77 Top Label

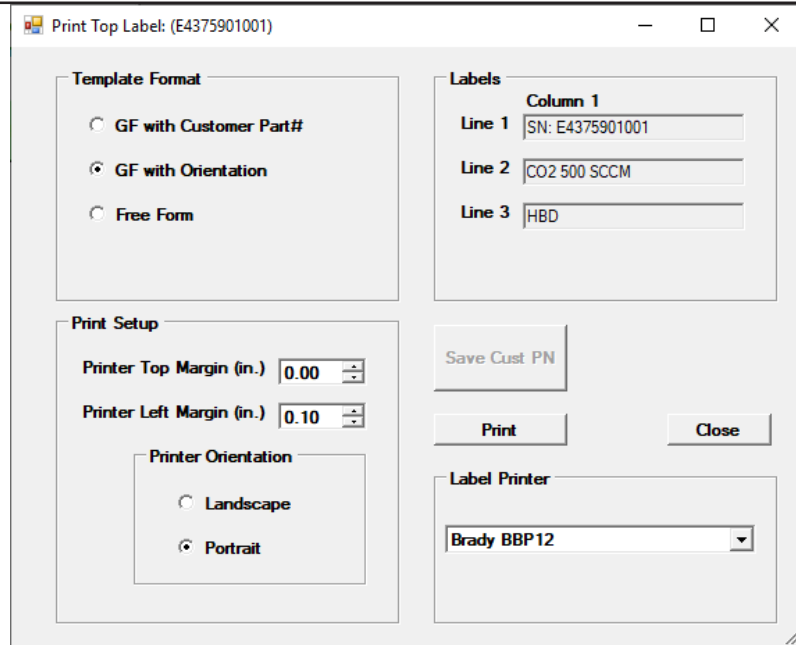

Figure 13-78 Print Top Label Window

For device label printing, a label printer is required. All printer models are supported – the user is responsible for installing the printer manufacturer’s drivers as needed, as well as setting up the printer settings such as form feed, margins, etc.

LIMITED WARRANTY

Visit www.BrooksInstrument.com for the terms and conditions of our limited warranty.

BROOKS SERVICE AND SUPPORT

Brooks is committed to assuring all of our customers receive the ideal flow solution for their application, along with outstanding service and support to back it up. We operate first class repair facilities located around the world to provide rapid response and support. Each location utilizes primary standard calibration equipment to ensure accuracy and reliability for repairs and recalibration and is certified by our local Weights and Measures Authorities and traceable to the relevant International Standards.

Visit www.BrooksInstrument.com to locate the service location nearest to you.

START-UP SERVICE AND IN-SITU CALIBRATION

Brooks Instrument can provide start-up service prior to operation when required.

For some process applications, where ISO-9001 Quality Certification is important, it is mandatory to verify and/or (re)calibrate the products periodically. In many cases this service can be provided under in-situ conditions, and the results will be traceable to the relevant international quality standards.

CUSTOMER SEMINARS AND TRAINING

Brooks Instrument can provide customer seminars and dedicated training to engineers, end users and maintenance persons.

Please contact your nearest sales representative for more details.

Due to Brooks Instrument's commitment to continuous improvement of our products, all specifications are subject to change without notice.

TRADEMARKS

Brooks is a trademark of Brooks Instrument, LLC

All other trademarks are the property of their respective owners.



Global Headquarters

Brooks Instrument
407 West Vine Street
Hatfield, PA
19440-0903 USA